



# SETUP SHEET

Track: Trackside Raceway

Driver: Todd Hodge

Indoor

Outdoor

Tight /  Open

Carpet

Concrete

Asphalt

Sealed

Smooth

Rough

Date: 1/11/03

## FRONT SUSPENSION

(Circle or Check the Appropriate Settings)

Pulley

Standard 42F 42R

Overdrive 41F 42R

Underdrive 42F 41R

Droop Height: 3mm

Pivot Support: 2F

In  
Toe  Out 1

Ride Height 5mm

-  
Camber  + 1

Caster:

Kickup 0

Antidive \_\_\_\_\_

Carrier 4

No  
Sway Bar  Yes size .060

Arm Spacing

FWD

MDL

BACK

Ackerman Position

Forward

Back

Front Drive:

Diff

One-Way

Spool

Camber

Ball Stud:

(Chrome)

(Black)

# of washers under steering/  
tie-rod ball studs

Spindle ball stud: 0

Bellcrank ball stud: 0

# and size of washers  
under camber ball stud 0

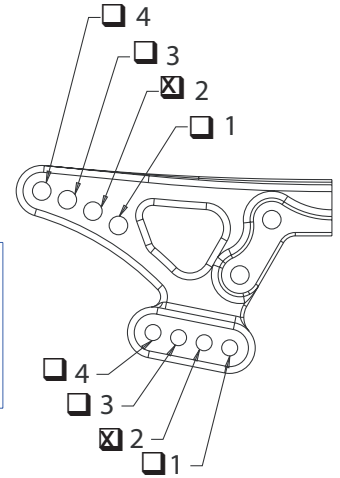

RollCenter:

High  Low

Other \_\_\_\_\_

Front Shocks

Oil: 80wt Shock Length: 60mm

Piston: 55  Standard /  Drilled

Spring: Purple

Limiters:  Inside \_\_\_\_\_  Outside .120

NOTES: Used new Team Losi XXX-S GP front low roll center mounts.

## REAR SUSPENSION

Camber  
Ball Stud:

(Chrome)

(Black)

# and size of washers  
under camber ball stud 0

Droop Height: 5.5mm

Pivot Support: 2R

In  
Toe  Out 2.5

Ride Height 5mm

-  
Camber  + 1

No  
Sway Bar  Yes size \_\_\_\_\_

Arm Spacing

FWD

MDL

BACK

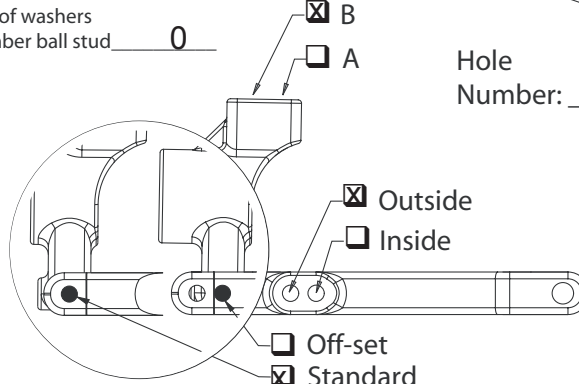

Hole  
Number: 3

RollCenter:

High  Low

Other \_\_\_\_\_

Rear Shocks

Oil: 70wt Shock Length: 65.7mm

Piston: 54  Standard /  Drilled

Spring: Silver

Limiters:  Inside 0  Outside .120

NOTES: \_\_\_\_\_

## Tires:

Compound

Insert

Wheel

Tire Dia.

Vehicle  
Weight

Front: Takeoff CS27(pre glued handout tire)

Rear: Takeoff CS27(pre glued handout tire)

53.0 oz

Battery Placement:  Back  Forward  Split: #Fwd \_\_\_\_\_ #Back \_\_\_\_\_  Tire Additive: TQ Mod

Transponder Position: Personal transponder mounted on top of servo.

Notes: Used Trinity Monster Stock. Geared 32/128.

Motor: Trinity 10x1 D5

Pinion: 27

Spur: 128

Body: TL Alfa

Body Height: ROAR

Wing: Step Wing