



MINI-T

Setup Sheet

Track: RC Madness-Enfield, CT

Driver: Andrew Gray

Date: 4/3/05

- | | | |
|--|---|---|
| <input checked="" type="checkbox"/> Indoor | <input type="checkbox"/> Asphalt | <input type="checkbox"/> Slippery |
| <input type="checkbox"/> Outdoor | <input checked="" type="checkbox"/> Carpet | <input checked="" type="checkbox"/> High-Bite |
| <input checked="" type="checkbox"/> Smooth | <input type="checkbox"/> Dirt | <input type="checkbox"/> Blue-Groove |
| <input type="checkbox"/> Rough | <input type="checkbox"/> Tight / <input checked="" type="checkbox"/> Open | |

FRONT SUSPENSION (Circle or Check the Appropriate Settings)

Toe In 0°
 Out 0°

Ride Height Arms just below level

Camber - 1°
 + 0°

of washers under steering / tie-rod ball stud
Spindle ball stud: 0
Bellcrank ball stud: 0

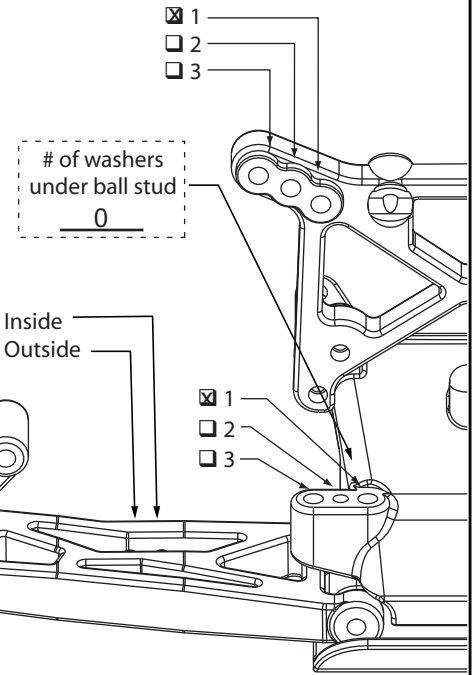

Front Shocks Type: Friction / Oil Filled
Oil Weight: 40
Piston: 3 Hole Standard / Drilled
Spring: AE Blue Type: Losi / Other
Limiters: Inside- 0 Outside- 0

REAR SUSPENSION

Toe-In Inside Stock°
 Outside 0°

Ride Height Dogbones just below level

Camber - 1°
 + 0°

Drive Shafts Dogbones CVDs

Sway Bar No
 Yes size

Body: Stock

Differential Type:
 Standard Gear
 Ball Differential

Rear Shocks Type: Friction / Oil Filled
Oil Weight: Losi 30
Piston: 2 Hole Standard / Drilled
Spring: AE Blue Type: Losi / Other
Limiters: Inside- 0 Outside- 0

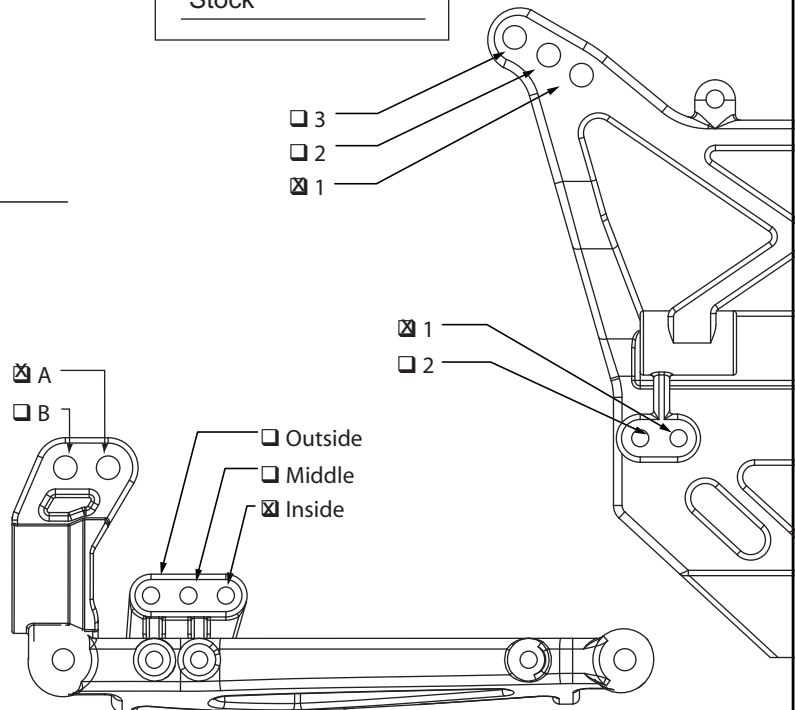

Tires
Front: Team Losi Cyan
Rear: Team Losi Purple

Electronics Standard / Other
Servo: JR Receiver: Novak XXL
Speed Controller: Novak Micro GT
Battery: Peak GP1100

Motor: Orion Baja Pinion/Spur: 16 / 60
Battery Position: Forward

Notes: Finished 2nd Overall at 1/18th Mini Nationals!!