



SETUP SHEET

Track: Standard Carpet

Driver: Matt Francis

Date: 1-13-03

Indoor
 Outdoor

Tight / Open

Carpet
 Concrete
 Asphalt

Sealed
 Smooth
 Rough

FRONT SUSPENSION

(Circle or Check the Appropriate Settings)

In
Toe Out 1
Ride Height 4mm
Camber -
 + 1/2
Caster:
 Kickup _____
 Antidive -3
 Carrier 6
 No
Sway Bar Yes size .070

Droop Height: 2mm

Pivot Support: 4

Arm Spacing Front Drive:
 FWD Diff
 MDL One-Way
 BACK Spool
Ackerman Position
 Forward
 Back

Camber Ball Stud:
 (Chrome)
 (Black)

Pulley
 Standard 42F 42R
 Overdrive 41F 42R
 Underdrive 42F 41R

of washers under steering/
tie-rod ball studs

Spindle ball stud: 0

Bellcrank ball stud: 0

and size of washers
under camber ball stud 0

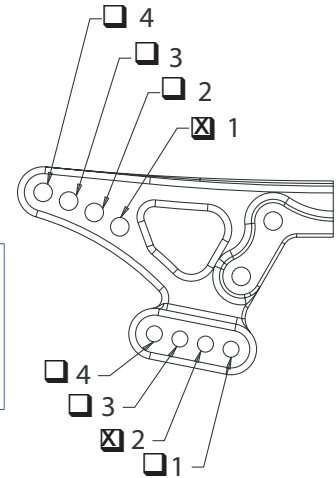

Roll Center:
 High Low
 Other _____

Front Shocks
Oil: 60 Shock Length: _____
Piston: 60 Standard / Drilled
Spring: Congo Purple
Limiters: Inside .050 Outside 0

NOTES: MF Alum Roll & Suspension Mounts
Low Roll Center raised .060
AE Full Hex

REAR SUSPENSION

In
Toe Out 2
Ride Height 5mm
Camber -
 + 1
 No
Sway Bar Yes size _____

Droop Height: 4mm

Pivot Support: 4

and size of washers
under camber ball stud 0

Arm Spacing
 FWD
 MDL
 BACK

Camber Ball Stud:
 (Chrome)
 (Black)

B
 A
Hole Number: 2
 Outside
 Inside
 Off-set
 Standard

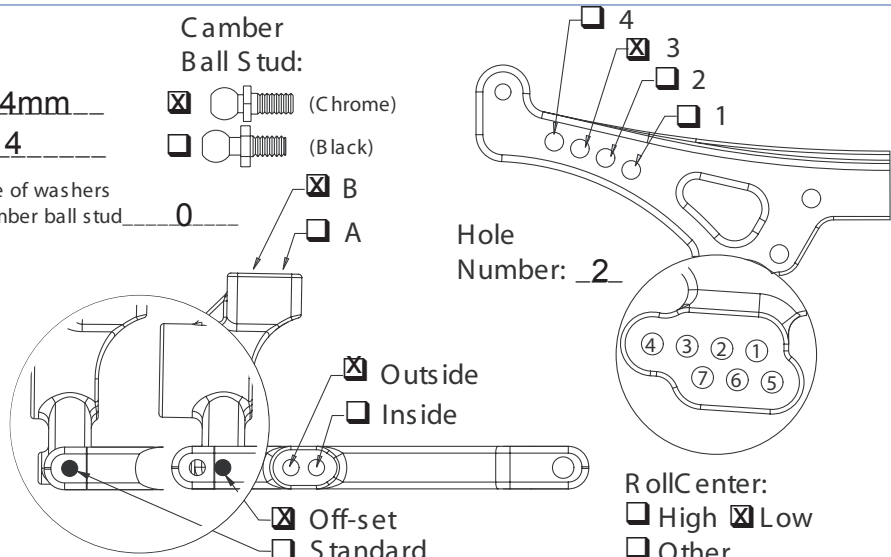

Roll Center:
 High Low
 Other _____

Rear Shocks
Oil: 60 Shock Length: _____
Piston: 55 Standard / Drilled
Spring: Congo Blue
Limiters: Inside 0 Outside 0

NOTES: MF Low Blocks and Suspension Mounts
AE Full Hex

Tires: Compound Plaid Insert _____ Wheel Black Tire Dia. 57.1mm Vehicle Weight _____
Front: TRC
Rear: TRC Tan/Magenta Multi-Ring Black 57.4mm

Battery Placement: Back Forward Split: #Fwd _____ #Back _____ Tire Additive: Paragon

Transponder Position: Personal Transponder mounted on top of servo

Notes: Used Trinity Monster Horsepower in stock. Gearing-33/128

Motor: 9x2
Pinion: 25
Spur: 128
Body: TL Alfa
Body Height: _____
Wing: Step Wing