



SETUP SHEET

Track: Trackside

Driver: Bobby Flack

Date: 1/12/04

<input checked="" type="checkbox"/> Indoor	<input checked="" type="checkbox"/> Carpet	<input type="checkbox"/> Sealed
<input type="checkbox"/> Outdoor	<input type="checkbox"/> Concrete	<input checked="" type="checkbox"/> Smooth
<input checked="" type="checkbox"/> Tight / <input type="checkbox"/> Open	<input type="checkbox"/> Asphalt	<input type="checkbox"/> Rough

FRONT SUSPENSION (Circle or Check the Appropriate Settings)

In
Toe Out 0

Ride Height 4.5mm

Camber - 1
 +

Caster:
 Kickup _____
 Antidive -2
 Carrier 6

Droop Height: 2mm

Pivot Support: 0F

Arm Spacing Front Drive:
 FWD Diff
 MDL One-Way
 BACK Spool

Ackerman Position
 Forward (flipped)
 Back

Pulley
 Standard 42F 42R
 Overdrive 41F 42R
 Underdrive 42F 41R

of washers under steering/tie-rod ball studs

Spindle ball stud: 0

Bellcrank ball stud: 0

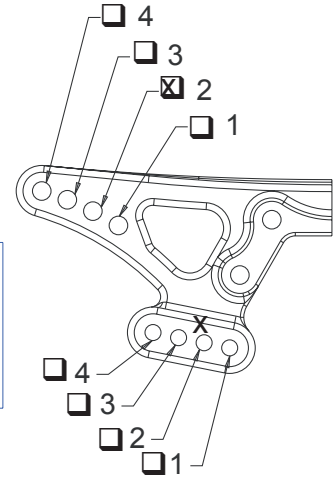

No
Sway Bar Yes size .070

Camber Ball Stud:
 (Chrome)
 (Black)

and size of washers under camber ball stud _____

RollCenter:
 High Low
 Other _____

Front Shocks
Oil: 40 Shock Length: _____
Piston: 57 Standard / Drilled
Spring: Trinity Purple
Limiters: Inside .120 Outside 0

NOTES: Drilled hole for inside camber link between 2 and 3.
Used TL low roll center mounts.
AE Hex on front

REAR SUSPENSION

In
Toe Out 2

Ride Height 4.5mm

Camber - 1
 +

Droop Height: 4mm

Pivot Support: 0R

and size of washers under camber ball stud 0

Arm Spacing
 FWD
 MDL
 BACK

Camber Ball Stud:
 (Chrome)
 (Black)

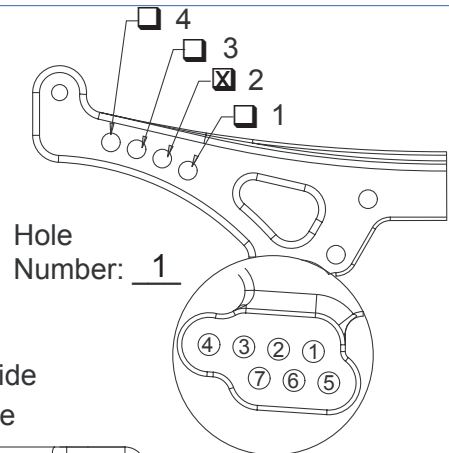

Hole Number: 1

No
Sway Bar Yes size .050

Rear Shocks
Oil: 40 Shock Length: _____
Piston: 56 Standard / Drilled
Spring: Trinity Blue
Limiters: Inside .120 Outside _____

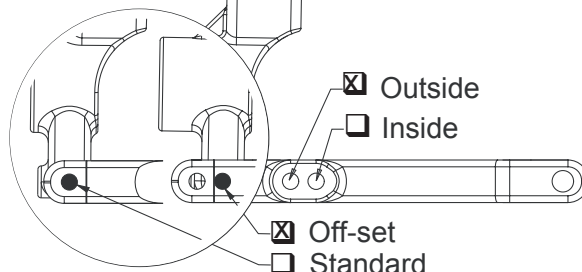

RollCenter:
 High Low
 Other _____

NOTES: _____

Tires: _____ Compound _____ Insert _____ Wheel _____ Tire Dia. _____ Vehicle Weight _____

Front: TRC Cyan 58mm

Rear: TRC Magenta 58mm 51.5oz

Battery Placement: Back Forward Split: #Fwd _____ #Back _____ Tire Additive: Corally

Transponder Position: _____

Notes: AE Hex on rear

Motor: Monster/ 19T

Pinion: 32 / 38

Spur: 128

Body: TL Afla

Body Height: 111mm

Wing: Type "A"