

# TEAMS SETUP SHEET EIGHT

Name: <u>Yannick</u>	Date: _____
City: _____ State: _____	Event: <u>Silver State</u>
Track: _____	

Indoor    Tight    Smooth    Hard Packed    Blue Groove    Wet    Low Bite    High Bite  
 Conditions    Outdoor    Open    Rough    Looser/Loamy    Dry    Dusty    Med Bite    Other \_\_\_\_\_

**Front Suspension**

Toe: -1°

Ride Height: 26 mm

Camber: -2°

Caster: Std

Sway Bar: Black 2.3 mm

Piston/Oil: 55 / 350

Spring: Silver

Limiters/Droop: Full

Overall Shock Length: \_\_\_\_\_

Steering Ackerman: Short

Bump Steer: Down

Camber Link: 3

Shock Location: Outside / 2

Front Diff Fluid: 7000

Receiver Battery Type: Nimh 1600

Center Diff Fluid: 5000

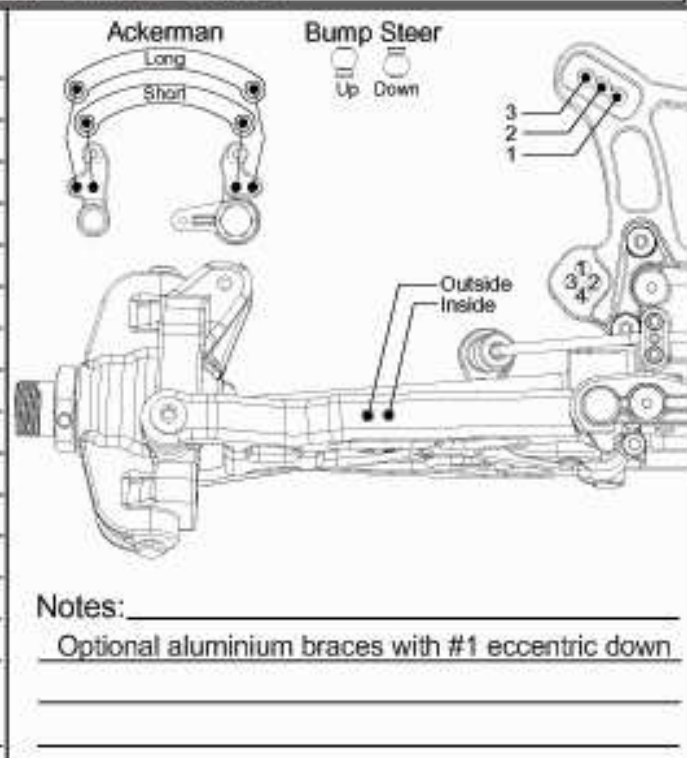

**Rear Suspension**

Toe: 3°

Anti-Squat: 3°

Ride Height: 29 mm

Camber: -3°

Rear Hub Spacing: One spacer back, 2 front

Sway Bar: Black 2.7 mm

Piston/Oil: 56 / 250

Spring: Green

Limiters/Droop: 107 mm

Overall Shock Length: \_\_\_\_\_

Camber Link: B / 2

Shock Location: Inside / 2

Rear Diff Fluid: 3000

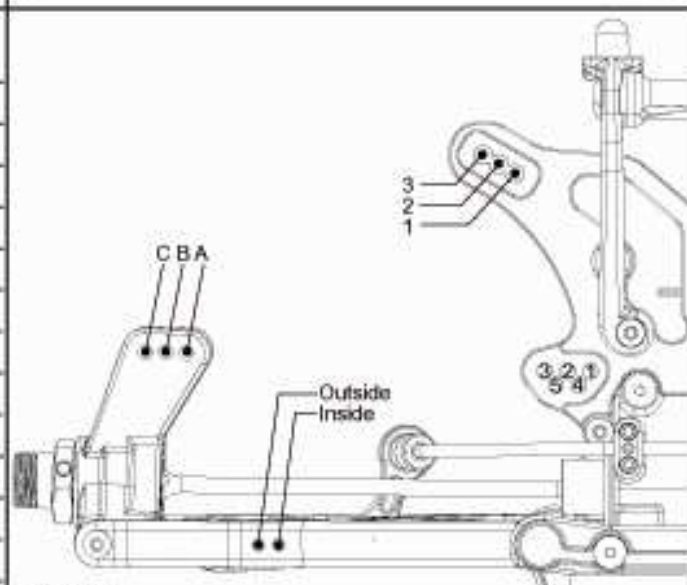

**Engine**

Engine: GRP Buggy Tuned Fuel: Nitrotane

Glow Plug: GRP n° 6 Head Clearance: Std

Pipe/Header: GRP 3009 / Long Gearing: 13 / 48

**Clutch**

Clutch Shoes and Springs Info

2 Aluminium shoes with Gold spring

2 Composite shoes with green spring

**Tires**

Type	Compound	Insert
Front: <u>GRP Jolly X</u>	_____	_____
Rear: <u>GRP Jolly X</u>	_____	_____

Notes: \_\_\_\_\_