

Name: _____		Date: _____	Event: _____
City: _____	State: _____	Track: _____	
Track <input type="checkbox"/> Indoor <input type="checkbox"/> Tight <input type="checkbox"/> Smooth <input type="checkbox"/> Hard Packed <input type="checkbox"/> Blue Groove <input type="checkbox"/> Wet <input type="checkbox"/> Low Bite <input type="checkbox"/> High Bite Conditions <input type="checkbox"/> Outdoor <input type="checkbox"/> Open <input type="checkbox"/> Rough <input type="checkbox"/> Loose/Loamy <input type="checkbox"/> Dry <input type="checkbox"/> Dusty <input type="checkbox"/> Med Bite <input type="checkbox"/> Other _____			

Front Suspension

Toe: 1/2°
 Ride Height: 1.22 in
 Camber: -1/2°
 Caster: Stock
 Sway Bar: No
 Oil: 30 wt.
 Piston: 57
 Spring: Silver
 Limiters: .210 in
 Spindle Height: Bottom
 Axle Spacer: Inside
 Axle Spacer Size: .100 in
 Steering Type: Bellcrank
 Bump Steer: 3 ball stud washers
 Camber Link: 2-B 2 washers under inner
 Shock Location: Inside
 VLA: Short

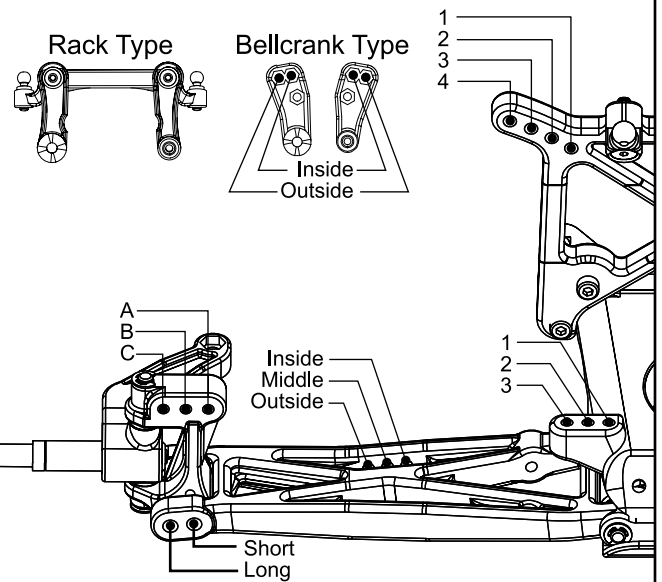

Notes: _____

Rear Suspension

Toe: 3°
 Pivot Support: _____
 Ride Height: 1.18 in
 Camber: -1°
 Rear Hub Spacing: Center
 Drive Shafts/Outdrives: CV/Steel
 Sway Bar: No
 Oil: 30 wt.
 Piston: 55
 Spring: White
 Limiters: No
 Camber Link: 2/B with 3 washers
 Shock Location: Middle
 VLA: Short
 Wing Width & Height: Stock
 Body Type: Stock
 Battery Position: Middle

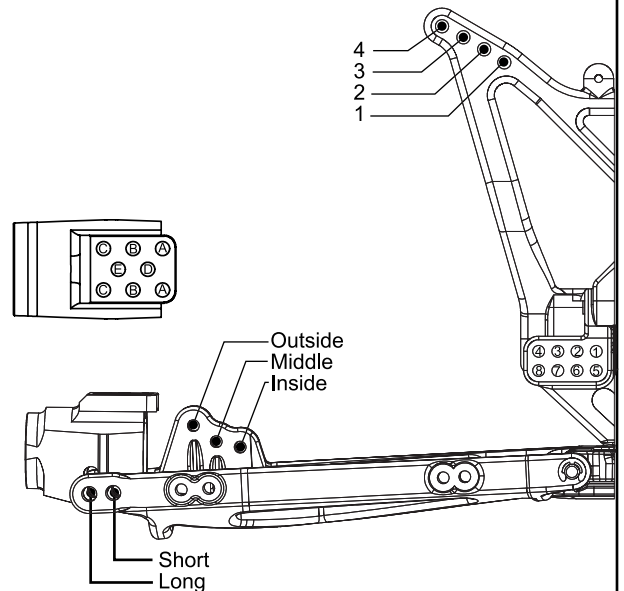

Notes: _____

Weight Placement
(Mark with "X")

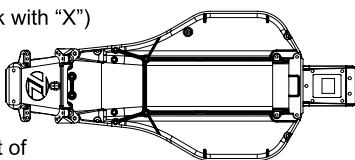

Weight of each piece _____ oz.

Tires: _____	Type _____	Compound _____	Insert _____	Additive _____	Motor: _____
Front: <u>8-Rib</u>	<u>Red</u>	_____	_____	_____	Spur: _____
Rear: <u>King Pin</u>	<u>Red</u>	_____	_____	_____	Pinon: _____

Notes: _____
