



## Owner's Manual

Congratulations on your purchase of a Losi Sport Mach 26SS engine. Precision manufactured and assembled, your engine will provide you with trouble-free performance if you read and follow these instructions.

### Using the Proper Fuel and Glow Plug

Using the proper fuel and glow plug is critical in order to achieve maximum performance and reliability. You must use fuel, glow plugs and air filters that are specifically designed for model car/truck/buggy applications. **Never use any type of model airplane glow fuel. Use of model airplane fuel can damage your engine and immediately void any warranty.**

We recommend using Team Losi® Nitrotane™ fuel with 20% nitro, providing the best combination of power and fuel economy. Team Losi fuels are vigorously tested, researched and formulated to deliver excellent power as well as engine protection.

A glow plug has been included and is ideal for breaking in your new engine. In fact, during the break-in procedure, it is not uncommon to go through one or two glow plugs, as microscopic bits of metal (from the cylinder/piston wearing in) bond themselves to the plug element causing glow plug failure. We recommend the Dynamite MC-59 glow plug (DYN2508) as the absolute best glow plug for this engine. This glow plug has been designed to deliver an ideal balance of performance and longevity.

All car engines must use a properly oiled air filter to keep dirt out of the engine. Any dirt that enters the carburetor can immediately destroy your engine. We recommend LOSB5020 as an excellent choice for a quality air cleaner.

### Carburetor Adjustments

Your engine comes equipped with a precision slide-valve carburetor. Take a moment to review the pictures below to familiarize yourself with the various functions of the carb. Loosening the nut located on the side of the crankcase under the carburetor body will allow you to rotate the carburetor. Make certain to mount the throttle arm to the side required by your particular vehicle. Although preset at the factory, some changes in the needle setting can occur during shipping and handling.

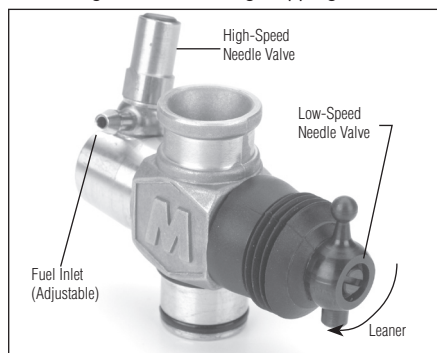

We suggest the following settings for breaking in your engine:

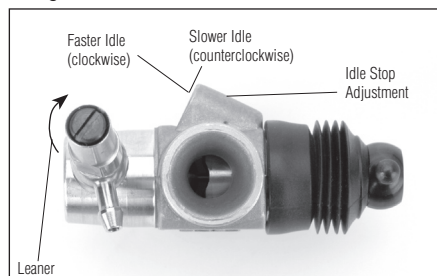

High-Speed Needle: 3 turns out (counterclockwise) from closed.

Low-Speed Needle: 2 $\frac{1}{4}$  turns out (counterclockwise) from closed.

**When checking the adjustment of the low-speed needle, it is crucial that the throttle slide is closed completely when turning the needle and that you do not over-tighten the needle. Use an engine-tuning screwdriver such as SWK9912 to make this job easier. When you feel resistance in the needle, immediately stop turning and begin turning the needles counterclockwise, counting the number of turns from “closed.”**

### Starting Your Engine for the First Time

The first start of your engine is the most critical time of the engine's life, dictating how well it will perform. After installing the engine in your model and inserting the glow plug, turn on your radio system and attach a glow igniter to the glow plug.

When using a recoil starter, never pull the rope out to its full length, as doing so may cause damage and recoil starter failure. Quick, short pulls of the recoil starter are the best technique to use. Never extend the starter rope more than 12 inches. Should the pull-starter be extremely difficult to pull (will not extend out of the assembly), the engine may be flooded (hydro-locked). Excess fuel between the cylinder head and piston will not allow the piston to travel through its full range of compression, effectively “locking up” the engine. Should this occur, immediately remove the glow igniter from the plug. Using a good quality glow plug wrench, remove the glow plug and turn the model upside down. Give the recoil starter a few short pulls to clear out the fuel, re-install the glow plug and start again. We recommend using an electric starter or starter box for the initial starts, even with a pull-start equipped engine.

**Never start an engine above 1/4 throttle. Immediate damage to your engine can and will occur.**

When the engine starts, the exhaust should emit lots of blue/white smoke, indicating that the engine is excessively rich (a good thing during break in). During the first tank of fuel, you may wish to set a higher than

normal idle speed and/or leave the glow plug igniter attached in order to keep the engine from stalling. Drive your vehicle around while “blipping” the throttle and avoid operating the engine at full throttle for more than 2–3 seconds at a time. Consume the entire first two tanks of fuel in this manner. After the first two tanks of fuel, begin leaning out the high-speed needle valve 1/8 turn at a time. It generally takes about 5 or 6 tanks of fuel before you'd want to start tuning for “maximum” power.

**Do not skip this process of breaking in a new engine! Should you choose not to follow these procedures, you risk damaging your engine during the first tank of fuel.**

Your patience during these procedures will be rewarded by an engine that performs reliably and to its maximum power potential. First run attempts can be more frustrating than with other (less powerful) sport engines, so take your time—it will be worth the wait. Glow plug failure is a common occurrence when breaking in a new engine. To test your plug, let the engine idle at a properly adjusted low-speed needle setting with the glow igniter attached. Then, remove the igniter. If you hear no appreciable change in engine rpm, the plug is still good. If the engine loads up and the rpm's decrease, it's time to replace the glow plug.

### Setting the Needle Valves

When tuning the needle valves for maximum performance, adjust them in small increments, 1/16 turn at a time.

An engine should not be run too lean; doing so severely shortens the life of the engine. When an engine is set too lean, it will run very strong at first but will soon begin to sag and hesitate or stall when accelerating.

The best way to tune an engine is by using an infrared temperature gauge, but you can also use water to check the head temperature (Refer to “Tuning the High-Speed Needle”).

## Tuning the High-Speed Needle

To obtain the correct high-speed needle setting, start the engine and drive your vehicle around for a minute or two, applying full throttle frequently. Place a drop of water on the cylinder head. If the water sizzles away (evaporates immediately) the needle setting is too lean. A correct needle setting will result in the water evaporating after 3-5 seconds. If the water does not evaporate, chances are good that the needle setting is too rich. Lean the needle 1/16 of a turn and run the engine again, adjusting the needle setting to get the desired evaporation time.

**Check the temperature each time you change the needle mixture. Do not let the engine overheat, as this will damage the engine.**

## Tuning the Low-Speed Needle

The low-speed needle (also referred to as the idle mixture or idle needle) should be set after you're satisfied with the high-speed needle setting. After achieving the proper operating temperature, reduce the engine throttle to idle and pinch the fuel line with your fingers close to the carb fuel inlet nipple. If the engine dies immediately, the low-speed needle is set too lean. If the rpm's increase dramatically, the setting is too rich. The ideal setting results in the rpm's increasing just a slight amount after pinching the fuel line.

## Idle Stop Adjustment

The last setting to be made is the idle stop screw. Turning this screw clockwise increases the idle speed; whereas turning the screw counterclockwise will make the engine idle at a lower speed. Ideally, the engine should idle just fast enough to be reliable in acceleration and transition from idle to full speed. Avoid an idle speed that is too fast, as it will cause damage to your clutch.

## Engine Maintenance

Periodic maintenance must be performed in order to keep your engine in proper operating condition. After each day of running, it's critical to use high quality after run oil to protect the internals of the engine and protect them against corrosion. The methanol used in the fuel attracts moisture that can cause corrosion (particularly in the ball bearings). Follow these steps after running your engine:

- 1) Empty all fuel from the tank and fuel lines
- 2) Remove the glow plug and air filter and add 5 to 6 drops of a quality after run oil into the carburetor and cylinder head openings. Turn the engine over a few times to distribute the oil throughout the engine.
- 3) Clean and inspect the engine, air cleaner and fuel system

## Troubleshooting Guide

<u>Problem</u>	<u>Possible Cause/Solution</u>
Engine won't start	<ul style="list-style-type: none"><li>• Clogged fuel line</li><li>• Bad or improper glow plug</li><li>• Glow igniter not charged</li></ul>
Engine starts, then dies	<ul style="list-style-type: none"><li>• Engine flooded</li><li>• Pressure line blocked or disconnected</li><li>• Bad glow plug</li></ul>
Engine starts and runs for 1/2 tank, then quits	<ul style="list-style-type: none"><li>• High-speed needle too lean</li><li>• Hole or tear in fuel line</li><li>• Bad glow plug idle speed set too low</li><li>• Overheated engine (too lean)</li><li>• Improper needle settings</li></ul>

## Warranty

### Limited Warranty Period

Horizon Hobby, Inc. guarantees this product to be free from defects in both material and workmanship at the date of purchase.

### Limited Warranty & Limits of Liability

Pursuant to this Limited Warranty, Horizon Hobby, Inc. will, at its option, (i) repair or (ii) replace, any product determined by Horizon Hobby, Inc. to be defective.

### In the event of a defect, these are your exclusive remedies.

This warranty does not cover cosmetic damage or damage due to acts of God, accident, misuse, abuse, negligence, commercial use, or modification of or to any part of the product. This warranty does not cover damage due to improper installation, operation, maintenance, or attempted repair by anyone other than an authorized Horizon Hobby, Inc. service center. This warranty is limited to the original purchaser and is not transferable. In no case shall Horizon Hobby's liability exceed the original cost of the purchased product and will not cover consequential, incidental or collateral damage. Horizon Hobby, Inc. reserves the right to inspect any and all equipment involved in a warranty claim. Repair or replacement decisions are at the sole discretion of Horizon Hobby, Inc. Further, Horizon Hobby reserves the right to change or modify this warranty without notice.

REPAIR OR REPLACEMENT AS PROVIDED UNDER THIS WARRANTY IS THE EXCLUSIVE REMEDY OF THE CONSUMER. HORIZON HOBBY, INC. SHALL NOT BE LIABLE FOR ANY INCIDENTAL OR CONSEQUENTIAL DAMAGES.

**As Horizon Hobby, Inc. has no control over use, setup, final assembly, modification or misuse, no liability shall be assumed nor accepted for any resulting damage or injury. By the act of use, setup or assembly, the user accepts all resulting liability.**

If you as the purchaser or user are not prepared to accept the liability associated with the use of this product, you are advised to return this product immediately in new and unused condition to the place of purchase.

### Safety Precautions

This is a sophisticated hobby product and not a toy. It must be operated with caution and common sense and requires some basic mechanical ability. Failure to operate this product in a safe and responsible manner could result in injury or damage to the product or other property. **This product is not intended for use by children without direct adult supervision.**

**The product manual contains instructions for safety, operation and maintenance. It is essential to read and follow all the instructions and warnings in the manual, prior to assembly, setup or use, in order to operate correctly and avoid damage or injury.**

### Questions, Assistance, and Repairs

Your local hobby store and/or place of purchase cannot provide warranty support or repair. Once assembly, setup or use of the product has been started, you must contact Horizon Hobby, Inc. directly. This will enable Horizon to better answer your questions and service you in the event that you may need any assistance.

### Questions or Assistance

For questions or assistance, please direct your email to [productsupport@horizonhobby.com](mailto:productsupport@horizonhobby.com), or call 877.504.0233 toll free to speak to a service technician.

### Inspection or Repairs

If your product needs to be inspected or repaired, please call for a Return Merchandise Authorization (RMA). Pack the product securely using a shipping carton. Please note that original boxes may be included, but are not designed to withstand the rigors of shipping without additional protection. Ship via a carrier that provides tracking and insurance for lost or damaged parcels, as Horizon Hobby, Inc. is not responsible for merchandise until it arrives and is accepted at our facility. Include your complete name, address, phone number where you can be reached during business days, RMA number, and a brief summary of the problem. Be sure your name, address, and RMA number are clearly written on the shipping carton.

### Warranty Inspection and Repairs

To receive warranty service, you must include your original sales receipt verifying the proof-of-purchase date. Providing warranty conditions have been met, your product will be repaired or replaced free of charge. Repair or replacement decisions are at the sole discretion of Horizon Hobby.

### Non-Warranty Repairs

Should your repair not be covered by warranty and the expense exceeds 50% of the retail purchase cost, you will be provided with an estimate advising you of your options. You will be billed for any return freight for non-warranty repairs. Please advise us of your preferred method of payment. Horizon Hobby accepts money orders and cashiers checks, as well as Visa, MasterCard, American Express, and Discover cards. If you choose to pay by credit card, please include your credit card number and expiration date. Any repair left unpaid or unclaimed after 90 days will be considered abandoned and will be disposed of accordingly.

**Electronics and engines requiring inspection or repair should be shipped to the following address (freight prepaid):**

Horizon Service Center  
4105 Fieldstone Road  
Champaign, Illinois 61822

**All other products requiring inspection or repair should be shipped to the following address (freight prepaid):**

Horizon Product Support  
4105 Fieldstone Road  
Champaign, Illinois 61822

© 2006 Horizon Hobby, Inc.

Team Losi engines are manufactured in Taiwan and distributed worldwide by:

Horizon Hobby, Inc.  
4105 Fieldstone Rd.  
Champaign, IL 61822  
[www.horizonhobby.com](http://www.horizonhobby.com)  
[www.teamlosi.com](http://www.teamlosi.com)



# Mach 26SS Engine w/Recoil

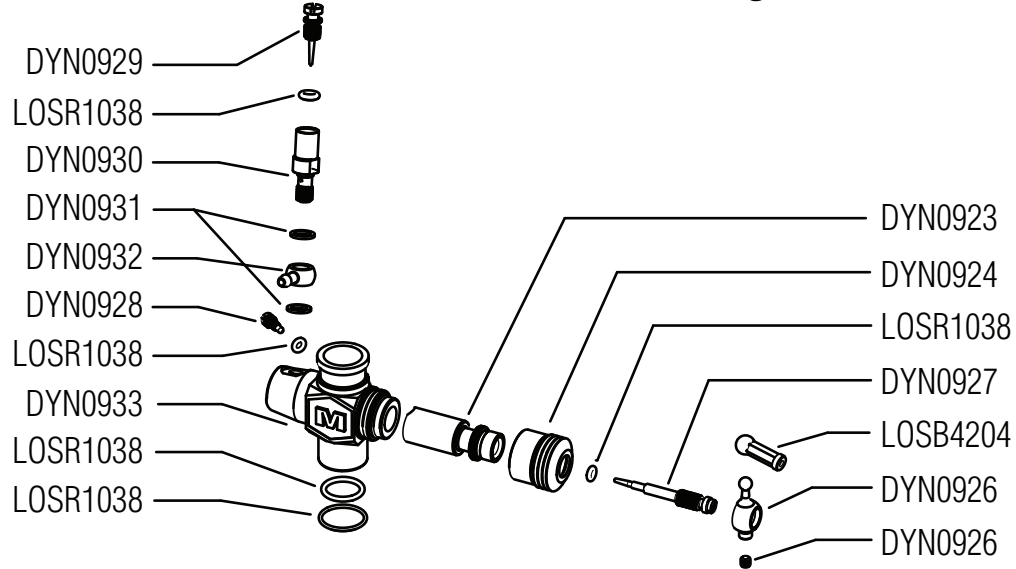

## CARBURETOR

LOSR1034  
Complete Recoil Starter

