

Name: _____
 City: _____ State: _____

Date: _____ Event: _____
 Track: _____

Track Conditions Indoor Tight Smooth Hard Packed Blue Groove Wet Low Bite High Bite
 Outdoor Open Rough Loose/Loamy Dry Dusty Med Bite Other _____

Front Suspension

Toe: 0
 Ride Height: **Arms Level**
 Camber: -1°
 Caster: 30°
 Oil: Losi 25 wt
 Piston: **Stock**
 Spring: 10th Slider Silver
 Limiters: 0
 Spindle Height: Low
 Bump Steer: **Stock**
 Camber Link: 2/B
 Shock Location: 2/Middle
 Front Wing: **Yes**
 Notes: _____

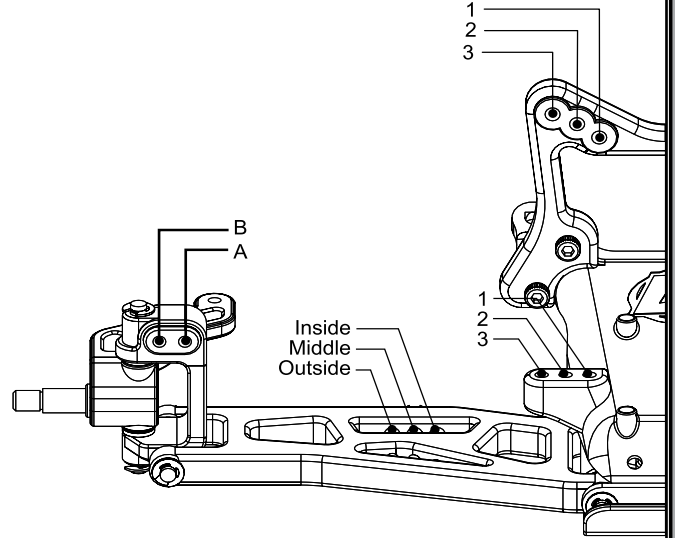

Rear Suspension

Toe: 3°
 Pivot Support: **Stock**
 Ride Height: **Bones Level**
 Camber: -1°
 Rear Hub Spacing: **Middle**
 Drive Shafts/Outdrives: **Dogbones (Stock)**
 Oil: Losi 25 wt
 Piston: **Stock**
 Spring: 10th Slider Silver
 Limiters: 0
 Camber Link: 2/A
 Shock Location: 2/Outside
 Battery Position: **Back**
 Notes: _____

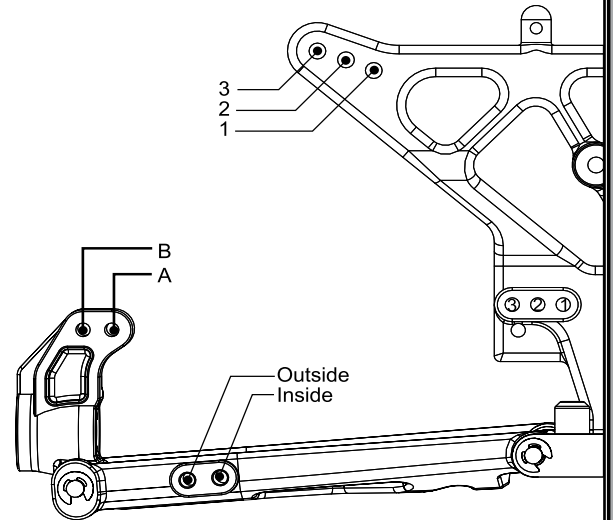

Wing Position

(Shade position hole)

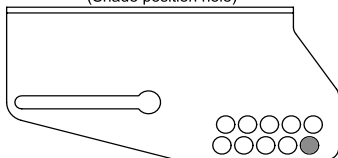

Tires: Type _____ Compound _____ Insert _____ Additive _____ Motor: **LM-32K**
 Front: _____ Spur: **90**
 Rear: _____ Pinon: **23**
 Notes: _____
