

# SETUP SHEET

Name: <b>10T</b>		Date: <b>9/1/09</b>	Event:
City:		State:	
Track		Track:	
Conditions: <input type="checkbox"/> Indoor <input type="checkbox"/> Tight <input checked="" type="checkbox"/> Smooth <input checked="" type="checkbox"/> Hard Packed <input type="checkbox"/> Blue Groove <input type="checkbox"/> Wet <input type="checkbox"/> Low Bite <input type="checkbox"/> High Bite <input type="checkbox"/> Dusty <input checked="" type="checkbox"/> Med Bite <input type="checkbox"/> Other _____			
Conditions: <input checked="" type="checkbox"/> Outdoor <input checked="" type="checkbox"/> Open <input type="checkbox"/> Rough <input type="checkbox"/> Loose/Loamy <input type="checkbox"/> Dry			

**Front Suspension**

Toe: **2 degrees OUT**

Ride Height: **30mm**

Camber: **-1 degree**

Caster: **Stock/20 degrees**

Sway Bar: **1.8mm**

Piston/Oil: **2 holes @ 1mm/30 wt**

Spring: **Black/Medium**

Limiters/Droop: \_\_\_\_\_

Overall Shock Length: **86mm Center to Center**

Steering Ackerman: **Long**

Bump Steer: **Down**

Camber Link: **Position 2**

Shock Location: **Position 2 / Center**

Front Diff Fluid: **Grease**

Receiver Battery Type: **1000mAh**

Center Diff Fluid: **Grease**

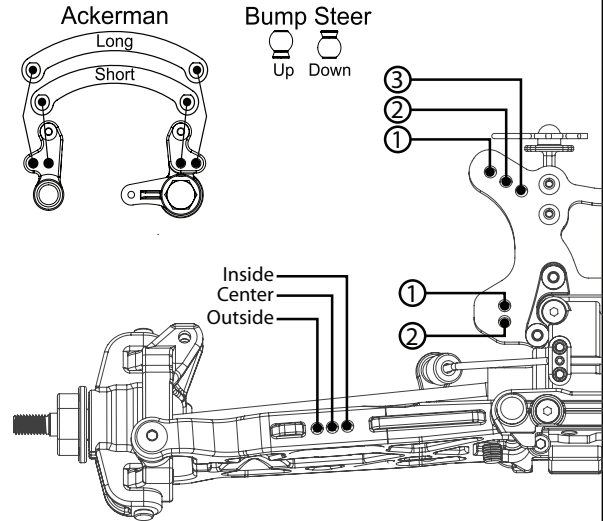

Notes: **Use 1.6mm Sway Bar for more steering**

**Rear Suspension**

Toe: **3 degrees**

Anti-Squat: **2 degrees**

Ride Height: **32mm**

Camber: **-1.5 degrees**

Rear Hub Spacing: **2 spacers on both sides**

Sway Bar: **2.0 mm**

Piston/Oil: **2 holes @ 1mm/30 wt**

Spring: **Black/Medium**

Limiters/Droop: \_\_\_\_\_

Overall Shock Length: **102.4mm Center to Center**

Camber Link: **Position 2 - B**

Shock Location: **Position 2 - Center**

Rear Diff Fluid: **Grease**

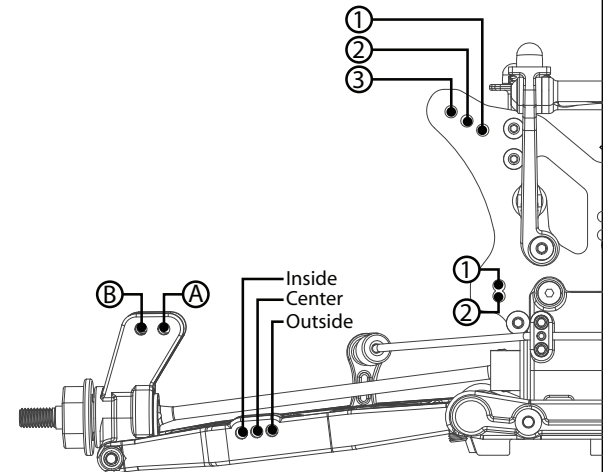

Notes: **Move rear hubs back for more on-power steering**

**Engine**

Engine: **Losi 3.4** Fuel: **Nitrotane 20%**

Glow Plug: \_\_\_\_\_ Head Clearance: **Stock**

Pipe/Header: **Stock** Gearing: **17/48**

**Notes**

---



---



---



---