

# SETUP SHEET

Track:

|  |                                 |                                      |
|--|---------------------------------|--------------------------------------|
| <input type="checkbox"/> Indoor                                | <input type="checkbox"/> Smooth | <input type="checkbox"/> Slippery    |
| <input type="checkbox"/> Outdoor                               | <input type="checkbox"/> Rough  | <input type="checkbox"/> High-Bite   |
| <input type="checkbox"/> Tight / <input type="checkbox"/> Open |                                 | <input type="checkbox"/> Blue-Groove |

Driver: \_\_\_\_\_  
Date: \_\_\_\_\_

## XXX-SCB

### FRONT SUSPENSION *(Circle or Check the Appropriate Settings)*

In  Out \_\_\_\_\_ °  
Ride Height \_\_\_\_\_  
Camber  -  + \_\_\_\_\_ °  
Caster  Stock  Other \_\_\_\_\_ °  
Sway Bar  No  Yes size: \_\_\_\_\_

# of washers under steering / tie-rod ball studs  
Spindle ball stud: \_\_\_\_\_  
Bellcrank ball stud: \_\_\_\_\_

#### Spindle Location

A  
 B  
 C  
 Top  
 Middle  
 Bottom

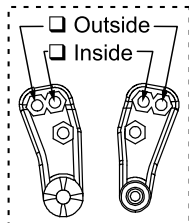

# of washers under ball stud:  
 1  
 2

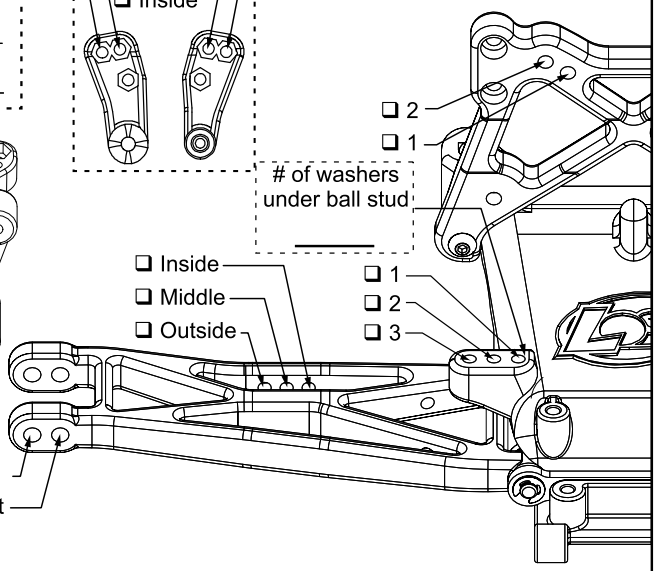
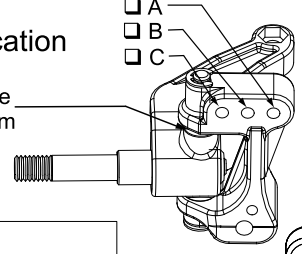

#### Front Shocks

Oil: \_\_\_\_\_  
Piston: \_\_\_\_\_  Standard /  Drilled  
Spring: \_\_\_\_\_ Internal:  Yes /  No  
Limiters:  Inside- \_\_\_\_\_  Outside- \_\_\_\_\_

### REAR SUSPENSION

Toe-In  Inside \_\_\_\_\_ °  
 Outside \_\_\_\_\_ °  
Pivot Support  No Shim  
 Shim Under Front  
 Shim Under Rear } # of shims: \_\_\_\_\_  
Ride Height \_\_\_\_\_  
Camber  -  + \_\_\_\_\_ °  
Rear Hub Spacing  Forward  Center  Rear  
Sway Bar  No  Yes size \_\_\_\_\_

Drive Shafts  Dogbones  Aluminum  
 CVDs  Steel  
Outdrives  Steel  Plastic

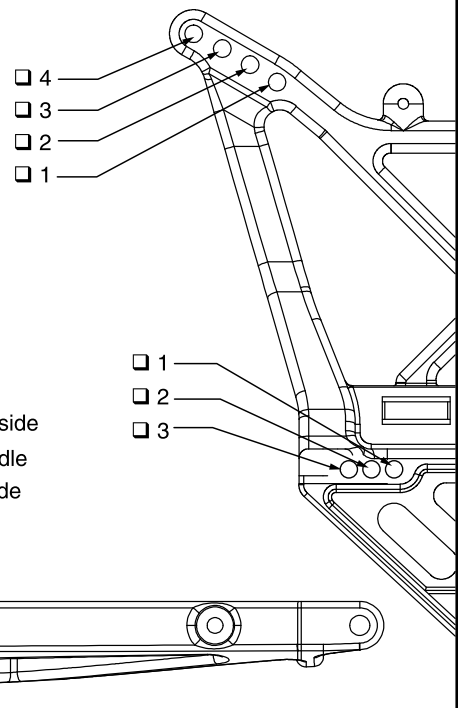

#### Rear Shocks

Oil: \_\_\_\_\_  
Piston: \_\_\_\_\_  Standard /  Drilled  
Spring: \_\_\_\_\_  
Limiters:  Inside- \_\_\_\_\_  Outside- \_\_\_\_\_

#### Tires

Front: \_\_\_\_\_ Compound \_\_\_\_\_ Foam \_\_\_\_\_  
Rear: \_\_\_\_\_ Compound \_\_\_\_\_ Foam \_\_\_\_\_

Motor: \_\_\_\_\_ Pinion/Spur: \_\_\_\_ / \_\_\_\_  
Battery Position: \_\_\_\_\_

Weather Conditions/Notes: \_\_\_\_\_