

SETUP SHEET

Track:

<input type="checkbox"/> Indoor	<input type="checkbox"/> Smooth	<input type="checkbox"/> Slippery
<input type="checkbox"/> Outdoor	<input type="checkbox"/> Rough	<input type="checkbox"/> High-Bite
<input type="checkbox"/> Tight / <input type="checkbox"/> Open		<input type="checkbox"/> Blue-Groove

Driver: _____
Date: _____

XXX-SCT

FRONT SUSPENSION *(Circle or Check the Appropriate Settings)*

In Out _____ °
Ride Height _____
Camber - + _____ °
Caster Stock Other _____ °
Sway Bar No Yes size: _____

of washers under steering / tie-rod ball studs
Spindle ball stud: _____
Bellcrank ball stud: _____

Spindle Location

Top
 Middle
 Bottom

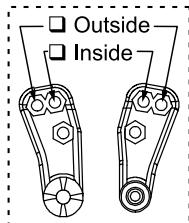
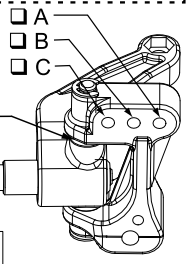

4
 3
 2
 1

of washers under ball stud: _____

Inside
 Middle
 Outside

1
 2
 3

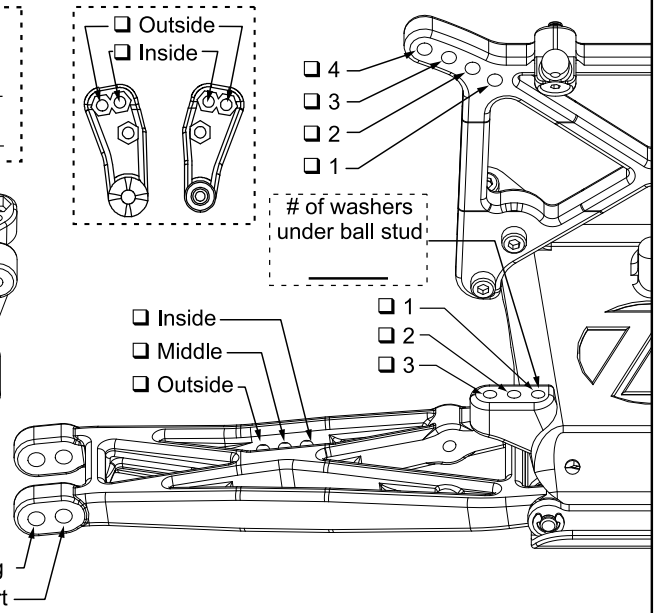

Front Shocks

Oil: _____
Piston: _____ Standard / Drilled
Spring: _____ Internal: Yes / No
Limiters: Inside- _____ Outside- _____

REAR SUSPENSION

Toe-In Inside _____ ° Outside _____ °
Pivot Support _____ No Shim Shim Under Front Shim Under Rear } # of shims: _____
Ride Height _____
Camber - + _____ °
Rear Hub Spacing Forward Center Rear
Sway Bar No Yes size _____

Drive Shafts Dogbones Aluminum CVDs Steel
Outdrives Steel Plastic

A
 B

Outside
 Middle
 Inside

1
 2
 3

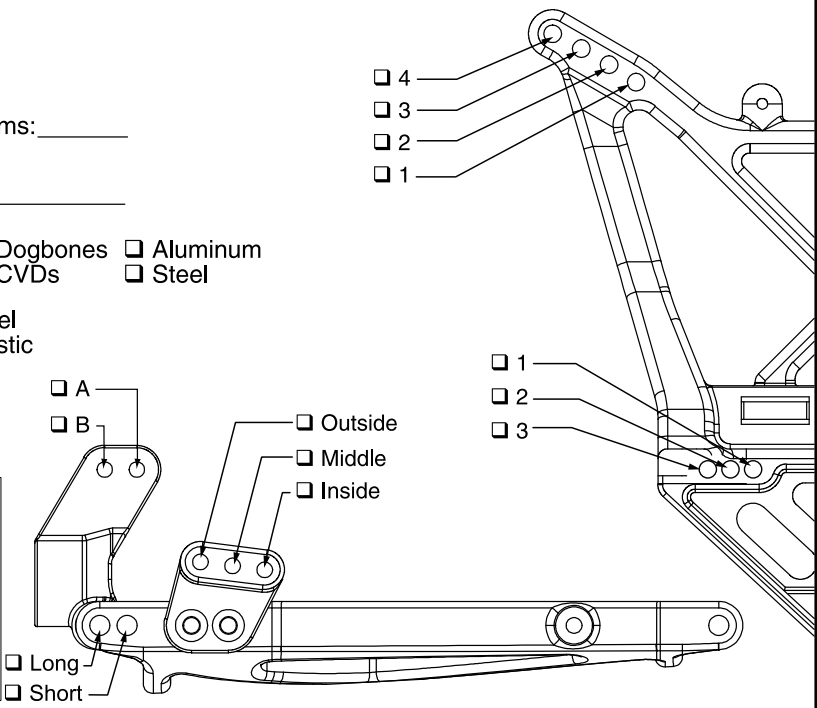

Rear Shocks

Oil: _____
Piston: _____ Standard / Drilled
Spring: _____
Limiters: Inside- _____ Outside- _____

Tires

Front: _____ Compound _____ Foam _____
Rear: _____ Compound _____ Foam _____

Motor: _____ Pinion/Spur: ____ / ____
Battery Position: _____

Weather Conditions/Notes: _____