

Name: Miguel Matias	Date: 2010-03-07	Event: Portugal Nats 2010
City: Portugal	State:	Track: Trofa
Track <input type="checkbox"/> Indoor <input type="checkbox"/> Tight <input type="checkbox"/> Smooth <input checked="" type="checkbox"/> Hard Packed <input checked="" type="checkbox"/> Blue Groove <input checked="" type="checkbox"/> Wet <input type="checkbox"/> Low Bite <input type="checkbox"/> High Bite Conditions <input checked="" type="checkbox"/> Outdoor <input checked="" type="checkbox"/> Open <input type="checkbox"/> Rough <input type="checkbox"/> Loose/Loamy <input type="checkbox"/> Dry <input type="checkbox"/> Dusty <input checked="" type="checkbox"/> Med Bite <input type="checkbox"/> Other _____		

Front Suspension

Toe: - 1°
 Ride Height: 27 mm.
 Camber: - 1°
 Caster: 12° Optional
 Sway Bar: 2,7 mm.
 Piston/Oil: 54 / 600 cps
 Spring: Green
 Limiter/Droop: 93 mm.
 Overall Shock Length: 93 mm.
 Steering Ackerman: Long
 Bump Steer: Up
 Camber Link: 2 / B
 Shock Location: 2 / Inside
 Receiver Battery Type: Losi LiPo

Differentials

Front: Standard Smart
 Spring Wire Dia: _____
 Qty of Springs: _____
 Ramp Plate: _____
 Grease: _____
 Diff Fluid: 5.000 cps
 Center: Standard Smart
 Spring Wire Dia: _____
 Qty of Springs: _____
 Ramp Plate: _____
 Grease: _____
 Diff Fluid: 5.000 cps

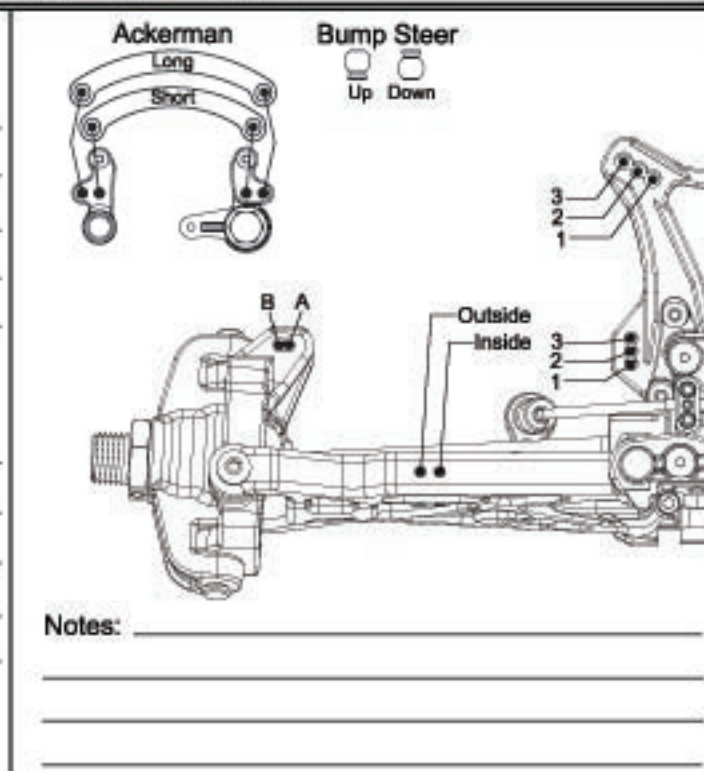

Rear Suspension

Toe: + 2°
 Anti-Squat: 3°
 Ride Height: 28 mm.
 Camber: - 3°
 Rear Hub Spacing: Front
 Sway Bar: 3 mm.
 Piston/Oil: 54 / 300 cps.
 Spring: Green
 Limiter/Droop: 106 mm.
 Overall Shock Length: 106 mm.
 Camber Link: 2 / C
 Shock Location: 2 / Inside
 Rear Diff Fluid: 3.000 cps

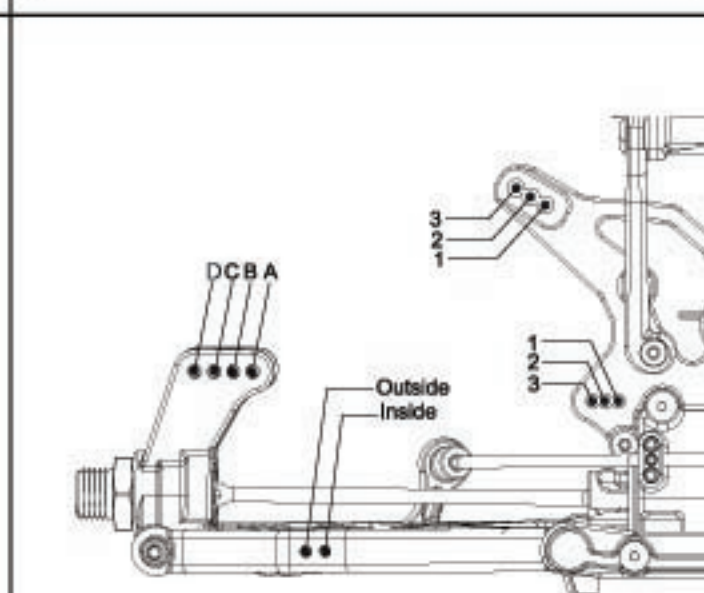

Engine

Engine: RB B9 Fuel: RB Fuel
 Glow Plug: RB #5 Turbo Head Clearance: .30
 Pipe/Header: RB 2045 w/192 Gearing: 13/47

Clutch

Clutch Shoes and Springs Info
2xAlu + 2xCarbon Shoes
2 x Black Springs
2 x Green Springs

Tires

Type	Compound	Insert
Front: <u>AKA Cross Brace Super Soft</u>	<u>AKA original</u>	<u>AKA original</u>
Rear: <u>AKA Cross Brace Super Soft</u>	<u>AKA original</u>	<u>AKA original</u>

Notes: Very Fast and very consistent. Victory, TQ and Fastest Lap