



MACH .15RE Owner's Manual

Congratulations on your purchase of a Mach 15RE engine! Precision manufactured and assembled, your Mach 15RE will provide you with trouble-free performance if you read and follow these instructions.

Using the Proper Fuel and Glow Plug

Using the proper fuel and glow plug is critical in order to achieve maximum performance and reliability. You must use fuel, glow plugs and air filters that are specifically designed for model car/truck/buggy applications. **Never use any type of model airplane glow fuel.** Use of model airplane fuel will damage your engine and immediately void any warranty.

We recommend using Blue Thunder or Blue Thunder Race Formula blend fuels with 20% nitro, providing the best combination of power and fuel economy. Dynamite® Blue Thunder Fuels are vigorously tested, researched and formulated to deliver excellent power as well as engine protection.

A glow plug has been included and is ideal for breaking-in your new engine. In fact during the break-in procedure, it is not uncommon to go through one or two glow plugs, as microscopic bits of metal (from the cylinder/piston wearing in) bond themselves to the plug element causing glow plug failure. We recommend the Dynamite MC-59 McCoy Power Plug (DYN2508) as the absolute best glow plug for this engine. Delivering an ideal balance of performance and longevity, this is the same glow plug that continues to win races at every level of competition, from local events to World Championships.

All car engines must use a properly oiled air filter to keep dirt out of the engine. Any dirt that enters the carburetor can immediately destroy your engine! We recommend DYN2503 or DYN2504 as excellent choices for quality air cleaners.

Carburetor Adjustments

Your Mach 15 RE engine comes equipped with a precision rotary-type carburetor. Take a moment to review the pictures below to familiarize yourself with the various functions of the carb. Loosening the nut located on the side of the crankcase under the carburetor body will allow you to rotate the carburetor. Make certain to mount the throttle arm to the side required by your particular vehicle.

Although preset at the factory, some changes in the needle setting can occur during shipping and handling.

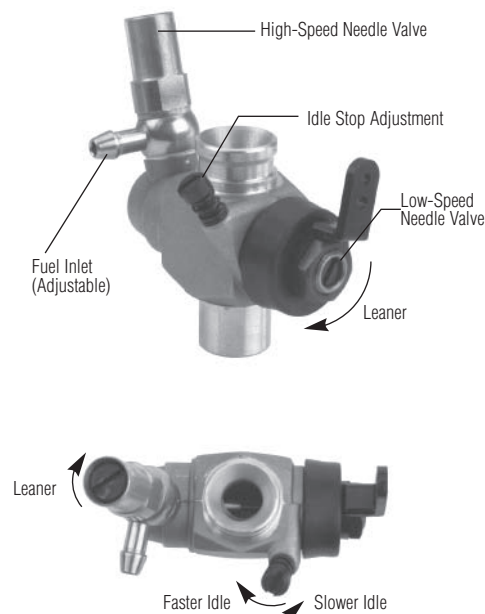

We suggest the following settings for breaking-in your engine:

High-Speed Needle: 3¹/₄ turns out (counterclockwise) from closed.

Low-Speed Needle: 3 turns out (counterclockwise) from closed.

When checking the adjustment of the low-speed needle, it is crucial that the throttle barrel is closed completely when turning the needle and that you do not over-tighten the needle. We suggest using a Dynamite® engine-tuning screwdriver (DYN2775) to make this job easier. When you feel resistance in the needle, immediately stop turning and begin turning the needles counterclockwise, counting the number of turns from "closed."

Starting Your Engine For The First Time

The first start of your engine is the most critical time of the engine's life, dictating how well it will perform. After installing the engine in your model and inserting the glow plug, turn on your radio system and attach a glow igniter to the glow plug.

When using a recoil starter, never pull the rope out to its full length, as doing so may cause damage and recoil starter failure. Quick, short pulls of the recoil starter are the best technique to use. Never extend the starter rope more than 12 inches.

Should the pull-starter be extremely difficult to pull (will not extend out of the assembly), the engine may be flooded (hydro-locked). Excess fuel between the cylinder head and piston will not allow the piston to travel through its full range of compression, effectively "locking up" the engine. Should this occur, immediately remove the glow igniter from the plug. Using a quality glow plug wrench (DYN2510), remove the glow plug and turn the model upside down. Give the recoil starter a few short pulls to clear out the fuel, re-install the glow plug and start again.

We recommend using an electric starter or starter box for the initial starts, even with a pull-start equipped engine.

You may need to "blip" the throttle on the transmitter (applying throttle on/off) while trying to start the engine, as new engines are more difficult to start due to the tight piston/cylinder fit. **Never start an engine above 1/4 throttle. Immediate damage to your engine can and will occur.**

When the engine starts, the exhaust should emit lots of blue/white smoke, indicating that the engine is excessively rich (a good thing during break-in). During the first tank of fuel, you may wish to set a higher than normal idle speed and/or leave the glow plug igniter attached in order to keep the engine from stalling. Drive your vehicle around while "blipping" the throttle and avoid operating the engine at full throttle for more than 2-3 seconds at a time. Consume the entire first two tanks of fuel in this manner.

After the first two tanks of fuel, begin leaning out the high-speed needle valve 1/8 turn at a time. It generally takes about 5 or 6 tanks of fuel before you'd want to start tuning for "maximum" power. **Do not skip this process of breaking-in a new or rebuilt engine. Should you choose not to follow these procedures, you risk damaging your engine in the first tank of fuel.**

Your patience during these procedures will be rewarded by an engine that performs reliably and to its maximum

power potential. First run attempts can be more frustrating than with other (less powerful) sport engines, so take your time—it will be worth the wait.

Glow plug failure is a common occurrence when breaking in a new engine. To test your plug, let the engine idle at a properly adjusted low-speed needle setting with the glow igniter attached. Then, remove the igniter. If you hear no appreciable change in engine rpm, then the plug is still good. If the engine loads up and the rpm's decrease, it's time to replace the glow plug.

Setting the Needle Valves

When tuning the needle valves for maximum performance, adjust them in small increments, 1/8 turn at a time.

An engine should not be run too lean; doing so severely shortens the life of the engine. When an engine is set too lean, it will run very strong at first but will soon begin to sag and hesitate or stall when accelerating.

The best way to tune an engine is by using an infrared temperature gauge, but you can also use water to check the head temperature. (Refer to "Tuning the High-Speed Needle" below.)

Tuning the High-Speed Needle

To obtain the correct high-speed needle setting, start the engine and drive your vehicle around for a minute or two, applying full throttle for periods of 5 seconds or more. Place a drop of water on the cylinder head. If the water sizzles away (evaporates immediately) the needle setting is too lean. A correct needle setting will result in the water evaporating after 3-5 seconds. If the water does not evaporate, chances are good that the needle setting is too rich. Lean the needle 1/8 of a turn and run the engine again, adjusting the needle setting to get the desired evaporation time. **Check the temperature each time you change the needle mixture. Do not let the engine overheat, as this will damage the engine.**

Tuning the Low-Speed Needle

The low-speed needle (also referred to as the idle mixture or idle needle) should be set after you're satisfied with the high-speed needle setting. After achieving the proper operating temperature, reduce the engine throttle to idle and pinch the fuel line for 3-5 seconds with your fingers close to the carb fuel inlet nipple. If the engine dies immediately, the low-speed needle is set too lean. If the rpm's increase dramatically, the setting is too rich. The ideal setting results in the rpm's increasing just a slight amount after pinching the fuel line.

Idle Stop Adjustment

The last setting to be made is the idle stop screw. Turning this screw clockwise increases the idle speed; whereas turning the screw counterclockwise will make the engine idle at a lower speed. Ideally, the engine should idle just fast enough to be reliable in acceleration and transition from idle to full speed. Avoid an idle speed that is too fast, as it will cause damage to your clutch.

Engine Maintenance

Periodic maintenance must be performed in order to keep your engine in proper operating condition. After each day of running, it's critical to use high quality after-run oil to protect the internals of the engine and protect them against corrosion. The methanol used in the fuel attracts moisture that can cause corrosion (particularly in the ball bearings). We recommend Blue Thunder™ Final Run (DYN2255) as it's specifically formulated to protect your engine between uses. Follow these steps after running your engine:

- 1) Empty all fuel from the tank and fuel lines
- 2) Use Final Run fuel following the instructions on the container
- 3) Clean and inspect the engine, air cleaner and fuel system

Troubleshooting Guide

Problem	Possible Cause/Solution
Engine won't start	<ul style="list-style-type: none"> • Reset needles to the factory setting • Incorrect needle settings • Out of fuel/old, bad or improper fuel • Clogged fuel line • Bad or improper glow plug • Glow igniter not charged • Engine flooded
Engine starts, then dies	<ul style="list-style-type: none"> • Pressure line blocked or disconnected • Bad glow plug • High-speed needle too lean • Hole or tear in fuel line
Engine starts and runs for ½ tank, then quits	<ul style="list-style-type: none"> • Bad glow plug idle speed set too low • Overheated engine (too lean) • Improper needle settings

Spare Part Listing

LOSR6535	Complete Pull Starter: Mach 15RE
LOSR6536	PS Backplate: Mach 15RE
LOSR6537	PS One-way Bearing: Mach 15RE
LOSR6538	PS Shaft: Mach 15RE
LOSR6539	PS Cushion Spring Mach 15RE
LOSR6540	PS Screw Set: Mach 15RE
LOSR6541	PS Handle Set: Mach 15RE
LOSR6542	PS Recoil Spring: Mach 15RE
LOSR6543	PS Rope & Pulley: Mach 15RE
LOSR6548	Carb Retainer Post & Nut: Mach 15RE
LOSR6552	Throttle Barrel: Mach 15RE
LOSR6553	Throttle Barrel Boot: Mach 15RE
LOSR6554	Throtle Arm W/ Nut: Mach 15RE
LOSR6555	High Speed Needle Valve: Mach 15RE
LOSR6556	High Speed Needle Holder: Mach 15RE
LOSR6557	High Speed Assembly Washers: Mach 15RE
LOSR6558	Fuel Inlet Nipple: Mach 15RE
LOSR6559	Low Speed Needle Valve: Mach 15RE
LOSR6564	Rotary Carburetor: Mach 15RE
LOSR6565	Complete O-Ring Set: Mach 15RE
LOSR6580	Cylinder Head: Mach 15RE
LOSR6581	Combustion Head Button: Mach 15RE
LOSR6582	Head Shim .1mm: Mach 15RE
LOSR6583	Head Shim .2mm: Mach 15RE
LOSR6584	Piston/Sleeve: Mach 15RE
LOSR6585	Wrist Pin: Mach: 15RE
LOSR6586	Wrist Pin Clips: 15RE
LOSR6587	Connecting Rod: Mach 15RE
LOSR6588	Front Bearing: Mach 15RE
LOSR6589	Collet: Mach 15RE
LOSR6590	Crankcase: Mach 15RE
LOSR6591	Header Seal: Mach 15RE
LOSR6592	Rear Bearing: Mach 15RE
LOSR6593	P/S SG Crankshaft: Mach 15RE
LOSR6594	Idle Screw: Mach 15RE
LOSR6595	O Ring Set: Mach 15RE

Warranty

Mach 15 RE engines are guaranteed against original defects in materials and workmanship for a period of 90 days from date of purchase. Mach 15 engines are of excellent quality and designed to provide many hours of racing enjoyment. If cared for properly, these engines are extremely durable. However, normal "common sense" care must be given to your engine in order to maximize its performance and service life. The following conditions/problems cannot be covered under warranty:

- Recoil starter
- Damage due to lack of maintenance
- Rusted bearings
- Crash-related damage (over-revving, runaways, free-wheeling, etc.)
- Damage due to use of improper fuel or glow plugs
- Damage due to lean runs (seized connecting rods, pistons, etc.)
- Damage caused by dirt or foreign objects being ingested into the engine
- Damaged from improper disassembly or reassembly
- Modification of any kind
- Normal engine wear

Should you need to send your engine in for warranty or non-warranty repairs, please follow these steps:

- 1) Ship your engine (in its original box) packed inside a sturdy box, freight prepaid to:

Horizon Service Center
ATTN: MACH 15 RE Service
4105 Fieldstone Rd.
Champaign, IL 61822
- 2) Include a note containing a brief summary of the problems you are experiencing with your MACH .15 RE engine. Please tell us:
 - Nitro content and brand of fuel used in the engine
 - Type of glow plug used
 - Type of air cleaner used
 - Approximate running time on the engine prior to difficulties developing

Date your correspondence and include your return shipping address, as well as a daytime telephone number and e-mail address (if applicable).

3) Warranty Repair

If you believe that the problem(s) with your engine are covered under warranty, you must include your original dated sales receipt to verify proof of purchase date. Providing the conditions of warranty have been met, your engine will be repaired without charge.

4) Non-Warranty Service

Should your repair costs exceed \$50.00, you'll be provided with an estimate advising you of your options. Any charges for return shipping of non-warranty repairs will be billed to you.

5) Payment Method

Please advise the Horizon Service Center of the method of payment you prefer to use. The Service Center accepts Visa or Master Card. When using credit cards, please include your card number, expiration date and the name as it appears on the card.

Mach 15 engines are manufactured in Taiwan and distributed worldwide by

Horizon Hobby, Inc.
4105 Fieldstone Rd.
Champaign, IL 61822
www.horizonhobby.com