

TEAM LOSI EIGHT

1/8th Scale Nitro Off Road Racing Truggy



Owner's Manual



ALWAYS RACING TOWARDS THE FUTURE.

Welcome Team Losi 8IGHT-T Owner!

Thank you for selecting the 8IGHT-T as your new racing truggy. The 8IGHT-T has already distinguished itself as a top caliber racing chassis and as you will see, we have made every effort to produce a chassis that is not only the most competitive but due to the race ready roller concept, also easy to use and maintain. Since building time has been greatly reduced you can get on the track sooner and concentrate on the finer points of the set-up covered in the tuning tips. Before you start to install the radio and engine in, read through the instructions to insure that your 8IGHT-T runs up to it's full potential from the first second it hits the track. The simple bag-by-bag assembly sequence and easily followed instructions and drawings combined with Team Losi's world famous quality fitting parts will make building the 8IGHT-T a most enjoyable project.

Before you open the first bag, or start assembly, please take a moment to read through the following instructions. This will familiarize you with the various parts, assembly tips, and descriptions as well as the tools needed. Taking an extra moment before starting can save a good deal of time and assure proper assembly.

Good luck and good racing,

Team Losi

8IGHT-T COMPLETED KIT SPECIFICATIONS

Overall Chassis Length: 18.2in (462mm)	Wheelbase: 12.64-12.80in (321-325mm)	*Front Track Width: 12.13in (308mm)
Overall Length w/Tires: 19-1/4in (489mm)	*Overall Height: 6-3/4in (171mm)	*Rear Track Width: 12.13in (308mm)

Note: Final kit weight will vary depending on accessories used.

**All measurements taken at ride height (36mm).*

Table 1: 8IGHT-T Completed Kit Specifications.

Kit/Manual Organization:

The kit is composed of different bags marked A through H. Each bag contains all of the parts necessary to complete a particular section of the kit. Some of these bags have sub-assembly bags within them. It is essential that you open only one bag at a time and follow the correct assembly sequence, otherwise you may face difficulties in finding the correct part. It is helpful to read through the instructions for an entire bag prior to beginning assembly. Next to each of the step numbers is a check box. At the completion of each step, place a check in this box so that if you must stop and come back to the assembly, you will be able to pick up where you left off.

For your convenience, an actual-size Hardware Identification Guide is included as a fold-out page at the back of this manual. Hardware that is not easily differentiable in each step is called out with an icon which contains a small picture of the part genre (referenced on the Hardware Identification Guide), the quantity of that part required for what is **shown** in the step, and the size or name of that part. To check a part, hold it against the silhouette until the correct part is identified. Associated with each of these parts, in the Hardware Identification Guide, is a LOSA-Number which is used when ordering replacement parts for your 8IGHT-T. In some cases, extra hardware has been supplied for parts that may be easy to lose.

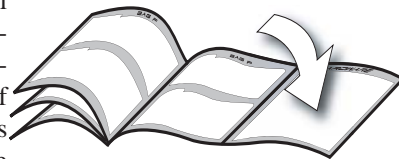

Components used in each step are identified by their relative LOSA-Number and the component's name. With the exception of a few parts, these are not referenced in the Hardware Identification Guide.

The molded parts in Team Losi kits are manufactured to de-

manding tolerances. When screws are tightened to the point of being snug, the parts are held firmly in place. For this reason, **it is very important that screws not be overtightened in any of the plastic parts.**

In some steps there will be a filled black circle with a white number. These indicate the specific order by which assembly must occur. In cases where steps are repeated (front/rear or left/right) these numbers may be omitted. Please note that these numbers will not call out every sub-step required for the step's assembly procedures, they will only highlight the critical order required for assembly.

In each step, there are specific "Detail Icons" (shaped like a stop sign) that call out critical precautions or assembly tips for the process. There is a reference key that describes the meaning of each of the icons located on the fold-out Hardware Identification Guide at the back of this manual.

To ensure that parts are not lost during construction, it is recommended that you work over a towel or mat to prevent parts from rolling away.

IMPORTANT SAFETY NOTES:

1. Select an area for assembly that is away from the reach of small children. *Some parts in this kit are small and can be swallowed by children, causing choking and possible internal injury; PLEASE USE CAUTION!*
2. The shock fluid and greases supplied should be kept out of children's reach. *They are not intended for human consumption!*
3. Exercise care when using any hand tools, sharp instruments, or power tools during construction.
4. Carefully read all manufacturer's warnings and cautions for any chemicals, glues, or paints that may be used for assembly and operating purposes.

TOOLS REQUIRED FOR ASSEMBLY

Team Losi has supplied all necessary Allen wrenches and a special wrenches that are needed for assembly and adjustments. The following common tools will also be required: Needle-nose pliers, regular pliers, hobby knife, scissors or other body cutting/trimming tools, and a soldering iron may be necessary for radio installation. 3/16", 1/4", 5/16", and 11/32" nut drivers are optional.

RADIO/ELECTRONICS

A suggested radio layout is provided in this manual. Your high performance R/C center should be consulted regarding specific questions pertaining to radio/electrical equipment.

HARDWARE IDENTIFICATION

When in question, use the Hardware Identification Guide at the back of this manual.

- For screws, the prefix number designates the thread size and number of threads per inch (i.e., 4-40 is a #4 size thread with 40 threads per inch). The second number, or fraction, designates the length of the screw. For cap head and button head screws, this number refers to the length of the threaded portion of the screw. For flat head and set screws, this number refers to the overall length of the screw.
- Bearings and bushings are referenced by the inside diameter (I.D.) x outside diameter (O.D.).
- Shafts and pins are designated by type (Roll, Solid) and referenced by diameter x length.
- Washers, Spacers and Shims are described by inside diameter or the screw size that will pass through the inside diameter x the thickness or by their designated application (i.e., Ball Stud washer is primarily used under a Ball Stud).
- Retaining Clips are sized by the shaft diameter that they attach to or by type (Body). The Hardware Icon associated with E/C-Clips only designates the part genre of clips, not the actual part.
- Nuts come in four types, Non-Flanged, Flanged (F), Plain, and Locking (L) (designated on the Hardware Icons). The prefix number designates the thread size and number of threads per inch. The second number, or fraction, designates the size of the hex. For example, L 4-40 x 1/4" designates a Lock nut that will thread onto a 4-40 screw using a 1/4" nut driver.
- Setscrews come in three types, Cup (C), Flat (F) and Oval (O) (designated on the hardware Icons). The prefix number designates the thread size and number of thread per inch. The second number, or fraction, designates the length of the threaded portion of the screw.

TABLE OF CONTENTS

SECTIONS

TABLES

1. INTRODUCTION.....	<i>i</i>
Kit/Manual Organization	<i>i</i>
Important Safety Notes	<i>i</i>
Tools Required for Assembly.....	<i>ii</i>
Radio/Electronics.....	<i>ii</i>
Hardware Identification	<i>ii</i>
2. Bag A: Steering Assembly	1-2
3. Bag B: Front Clip	3-8
4. Bag C: Center Transmission.....	9-12
5. Bag D: Rear Clip	13-18
6. Bag E: Shocks	19-21
7. Bag F: Radio Tray	22-26
8. Bag G: Engine Installation	27-30
9. Bag H: Wheels, Tires, Body	31-34
8. Checklist Before Your First Run	35
9. Setup Guide	35-39
10. Blank 8IGHT-T Setup Sheet	24
11. Hardware Identification Guide	25
12. Filled-out 8IGHT-T Kit Setup Sheet	26

Table 1: 8IGHT-T Completed Kit Specifications	<i>i</i>
Table 2: Servo Installation	23



Team Losi is continually changing and improving designs; therefore, the actual part may appear slightly different than the illustrated part. Illustrations of parts and assemblies may be slightly distorted to enhance pertinent details.

Cap Head

- 2-56 x 1/4" (A6232)
- 2-56 x 1/2" (A6254)
- 4-40 x 3/8" (A6206)
- 4-40 x 1/2" (A6204)
- 4-40 x 5/8" (A6221)
- 5-40 x 1/2" (A6240)
- 5-40 x 7/8" w/ 5/8" Shoulder (A4414)

Flat Head 1

- 3 x 8mm (A9104)
- 3 x 12mm (A3500)
- 5-40 x 3/8" (A6270)
- 5-40 x 1/2" (A6271)
- 5-40 x 3/4" (A6272)
- 5-40 x 7/8" (A6273)

Flat Head 2

- 8-32 x 3/8" (A6264)
- 8-32 x 1/2" (A6262)
- 5-40 x 1-7/8" (A6273)

Button Head

- 2-56 x 1/4" (A6255)
- 4-40 x 1/4" (A6234)
- 4-40 x 1/2" (A6256)
- 5-40 x 3/8" (A6277)
- 5-40 x 1/2" (A6278)
- 5-40 x 3/4" (A6279)
- 5-40 x 1" (A6280)
- 8-32 x 3/4" (A6263)

Set

- F 5-40 x 1/8" (A6228)
- C 4-40 x 1/8" (A6227)
- C 5-40 x 3/16" (A6299)
- C 8-32 x 1/8" (A6298)
- F 5-40 x 1/8" (A6297)
- F 8-32 x 1/8" (A6296)
- O10-32 x 3/8" (A6295)
- 5-40 x 5/8" (A6043)

Ball Bearings 1

- 5x10x4mm (A6949)
- 6x10x3mm (A6946)
- 5x11x4mm (A6947)
- F 5x11x4mm (A6948)

Ball Bearings 2

- 5x13x4mm (A6949)
- 8x14x4mm (A6945)
- 1/2" x 3/4" (A6953)

Pins

- 2.5 x 14mm (A3525)
- 2.5 x 12.37mm (A3523)
- 3 x 17mm (A3531)
- 2.5 x 12.8mm (A3505)
- 4 x 66mm (A6500)

Washers

- Ball Stud (A6215)
- #4 x .030" (A6350)
- .250 x .094 x .020" (A9166)

Shims

- 5x7x.2mm (A9104)
- 6x8x.2mm (A6356)

Retaining Clips

- 5mm E-Clip (A6109)
- Body Clip (A8200)

Nuts (Lock/Plain)

- #4-40 (Mini) (A6306)
- #5-40 (A6302)
- #8-32 (A6311)

DETAIL ICON REFERENCE KEY

1 These numbers are used to identify the critical order in which assembly must occur. *Note: They will not call out every stage of the assembly process.

Apply Loctite®	Apply Clear Grease	Apply CA Glue	Degrease with Motor Spray	Fill With Silicone Oil	Pre-Tap
Pay Special Attention	Cut/Trim	Ensure Free Movement	Ensure Free Rotation	Ensure Proper Orientation	Push Firm
Side Shown	Assemble Other Side the Same	Repeat/Build Multiple	Screw Partially	DO NOT Over Tighten/ Snug Tight	Tighten

STEP A-01

Steering Link Assembly

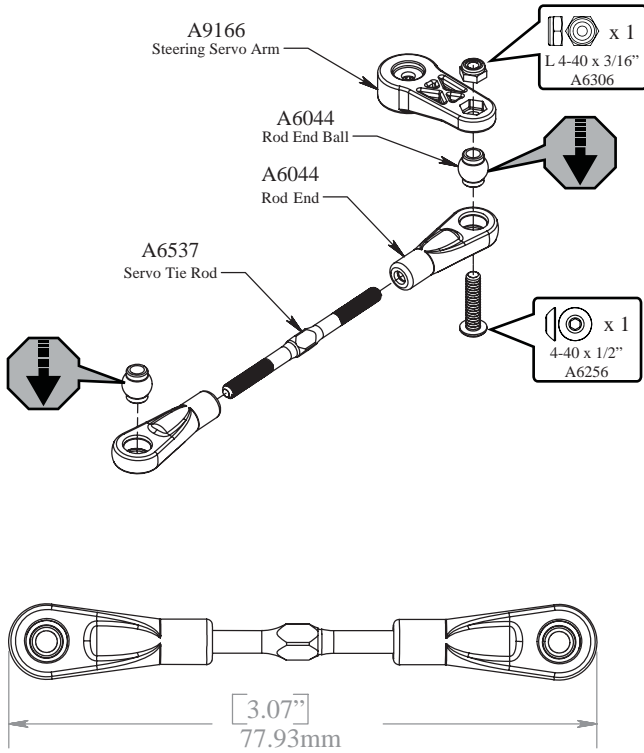

STEP A-02

Servo Saver Assembly

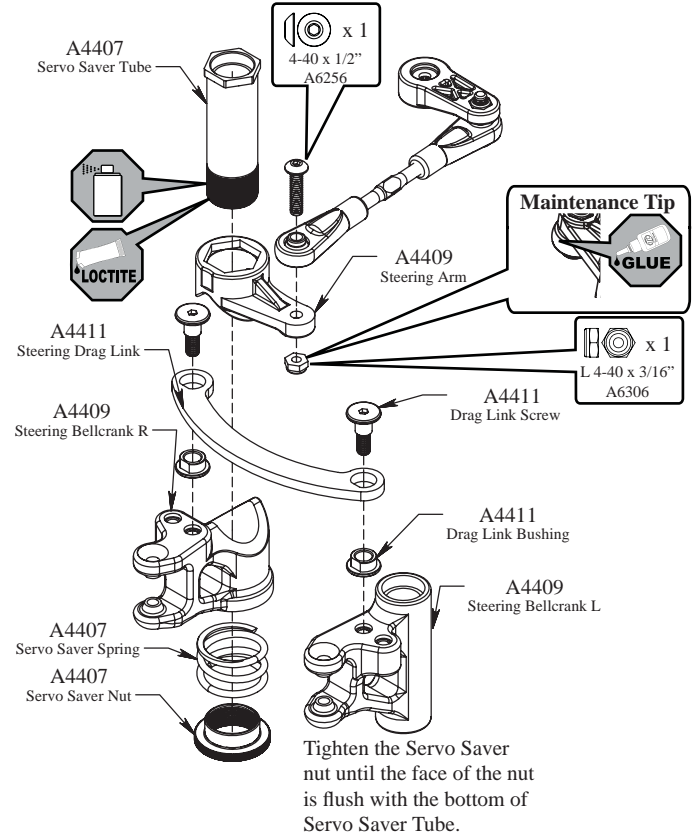

STEP A-03

Fuel Tank/Chassis Brace Assembly

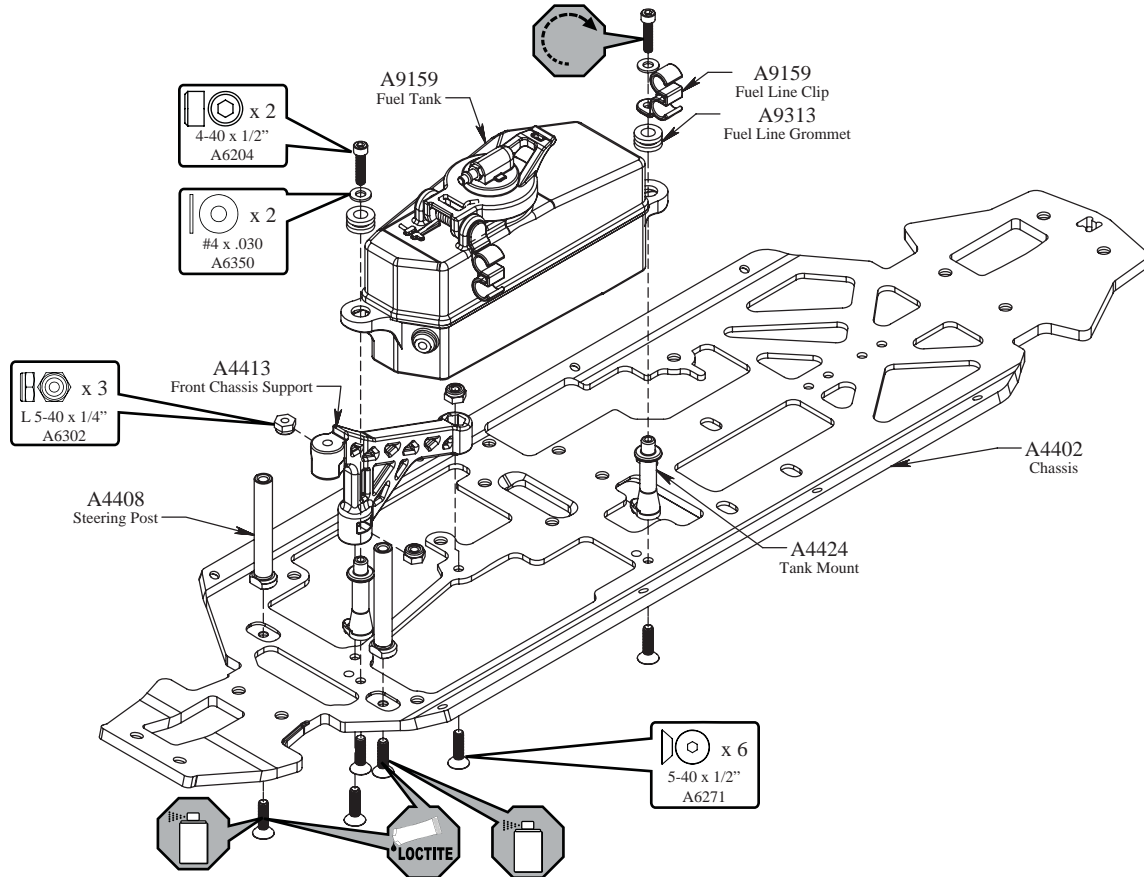

STEP A-04

Steering/Top Plate Assembly

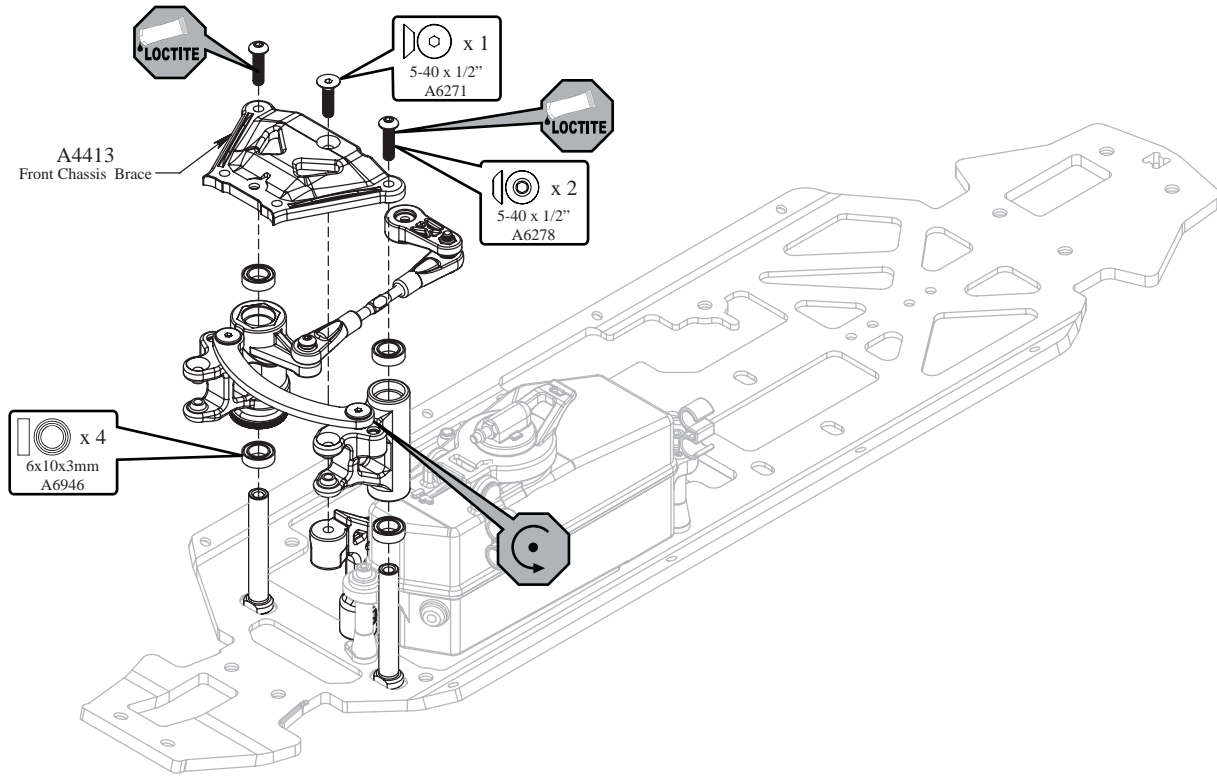

STEP A-05

Completed Steering Assembly

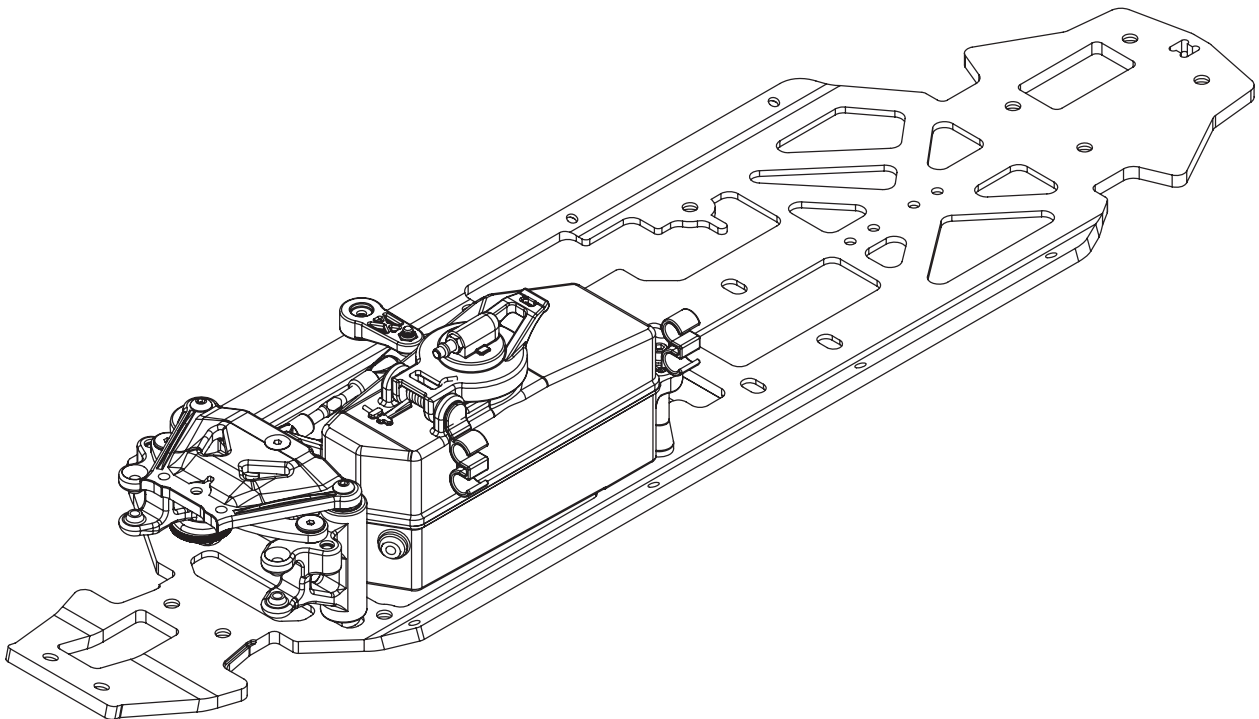

STEP B-01

Ring Gear Assembly

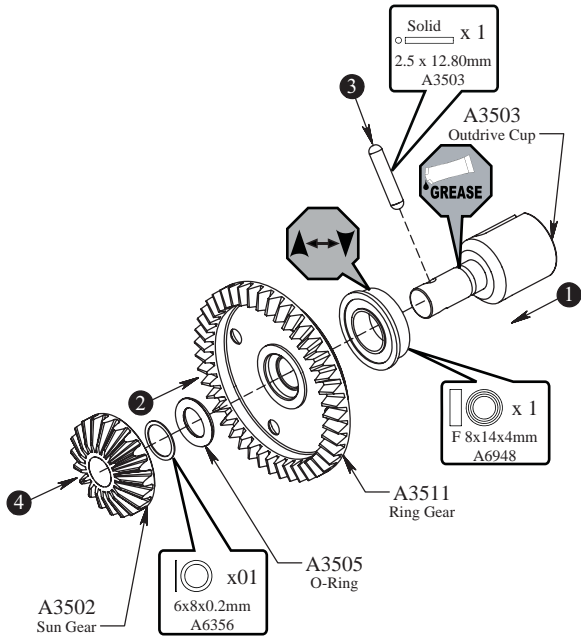

STEP B-02

Diff Case Assembly

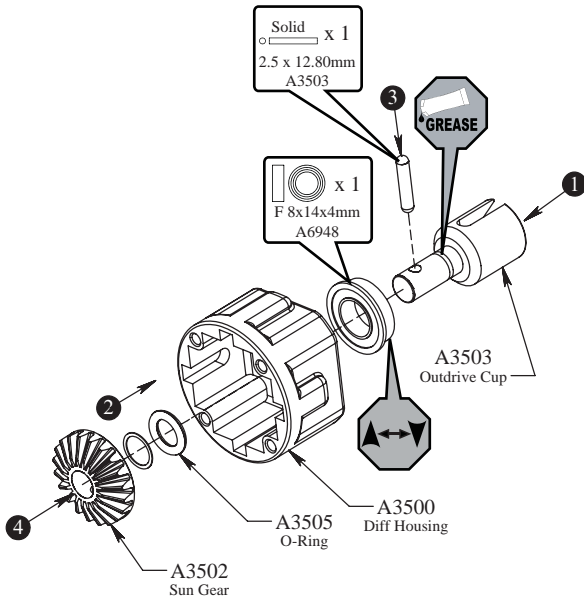

STEP B-03

Complete Diff Assembly

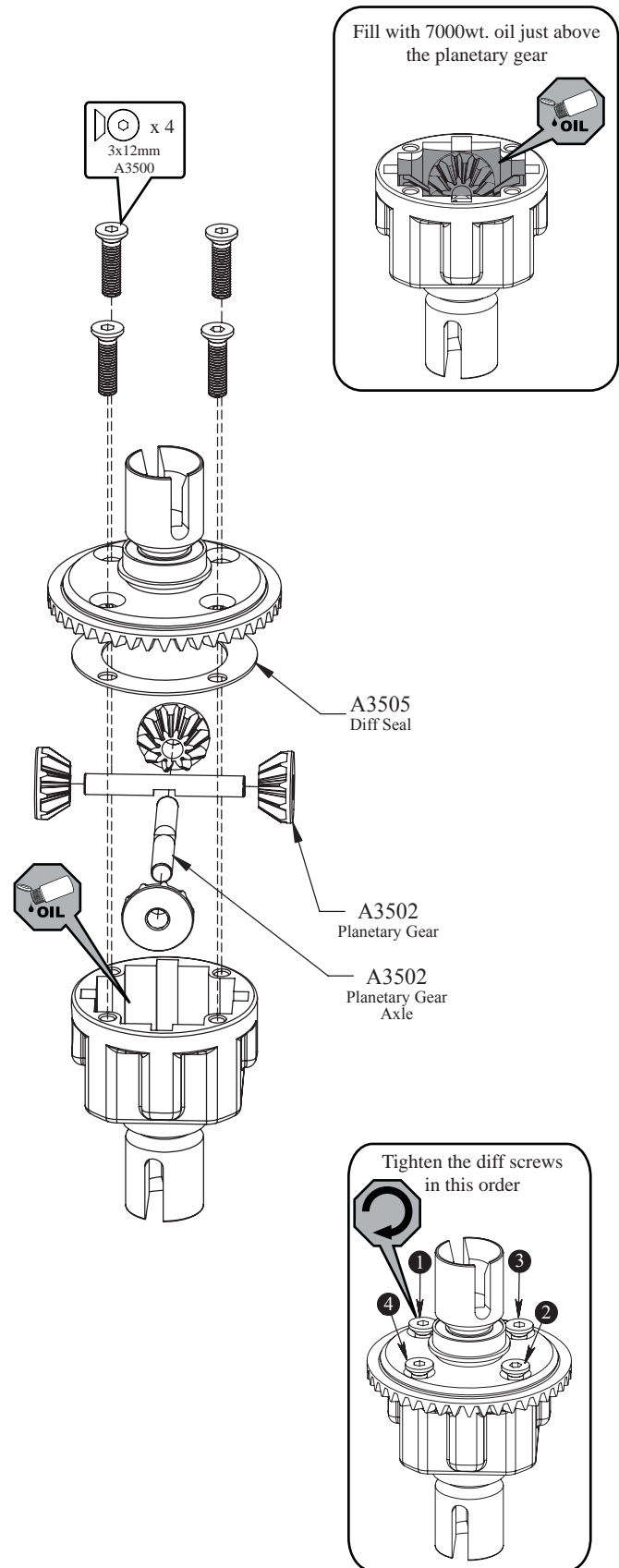

STEP B-04

Front Diff Install

- To prevent fine dust from entering the gear box, apply a thin bead of grease along the edge of the case as pictured.

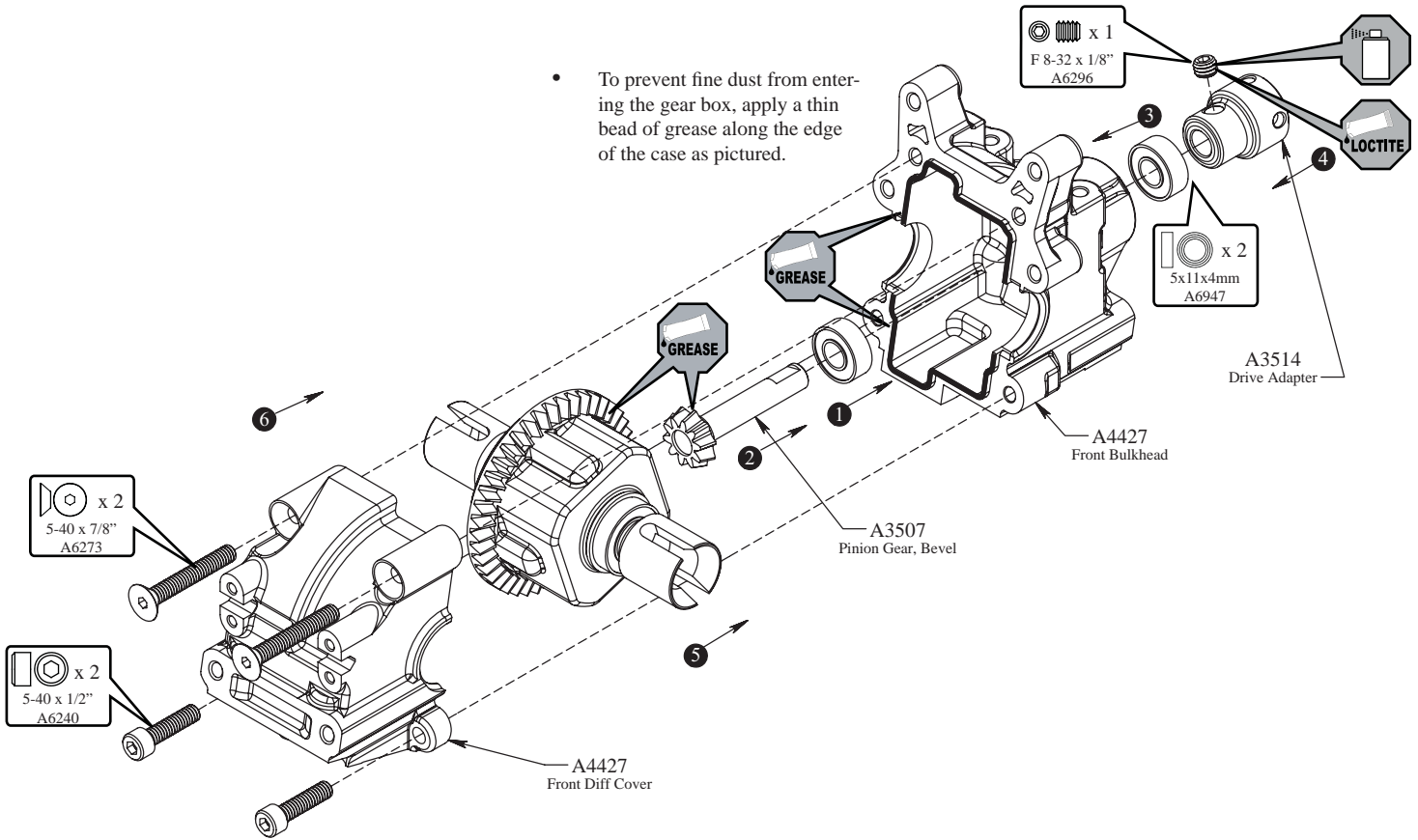

STEP B-05

Front Spindle & CV Assembly

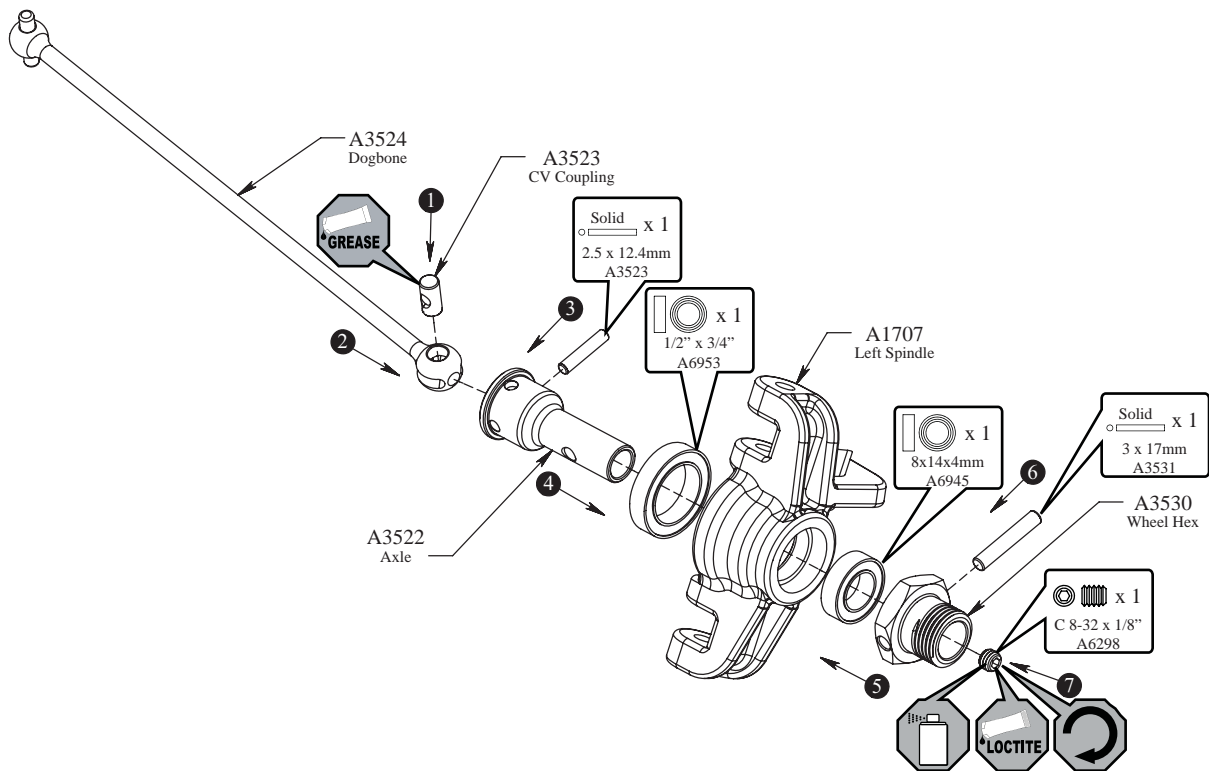

STEP B-06

Spindle/Carrier Assembly

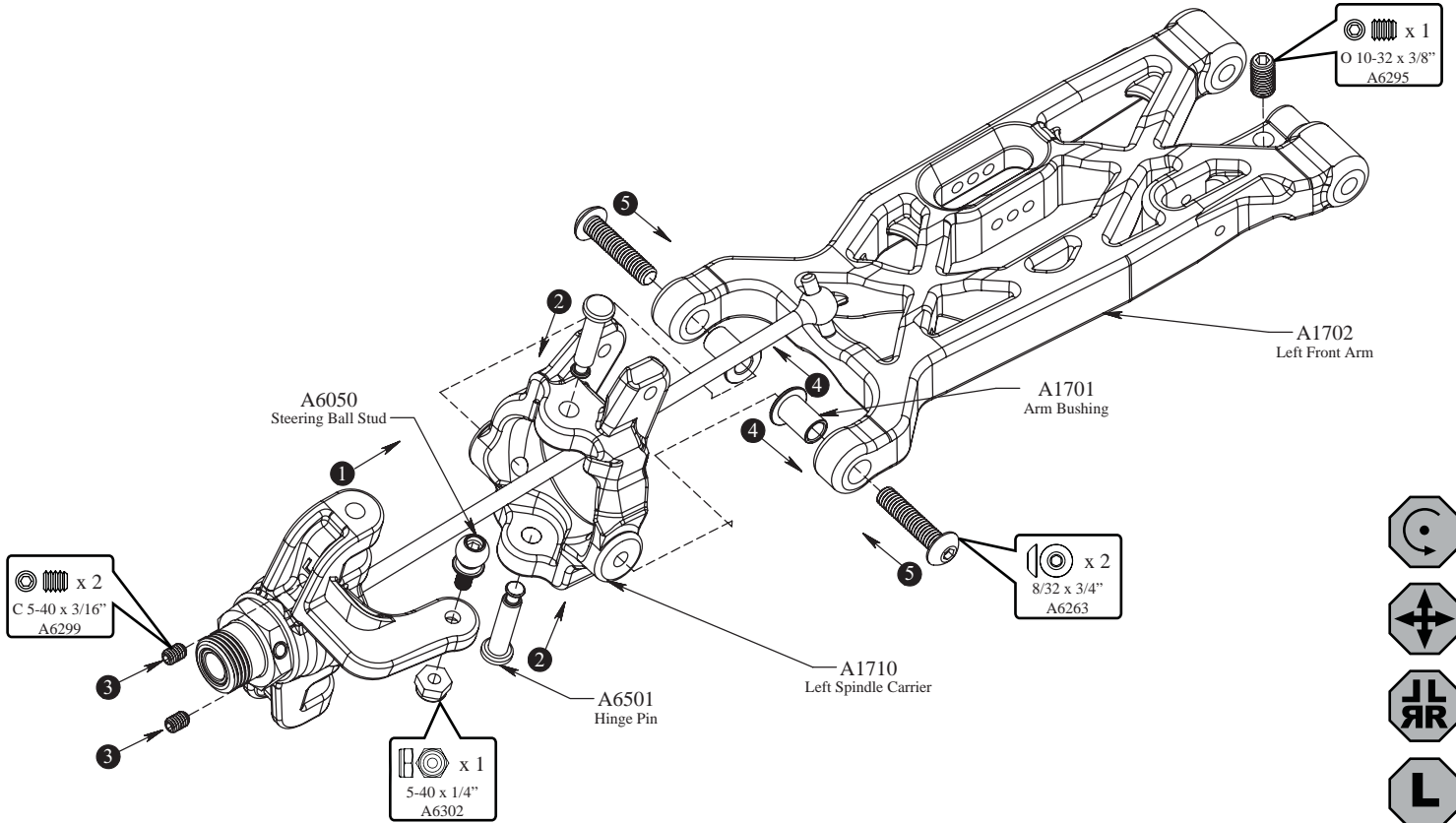

STEP B-07

Front Suspension Arms Assembly

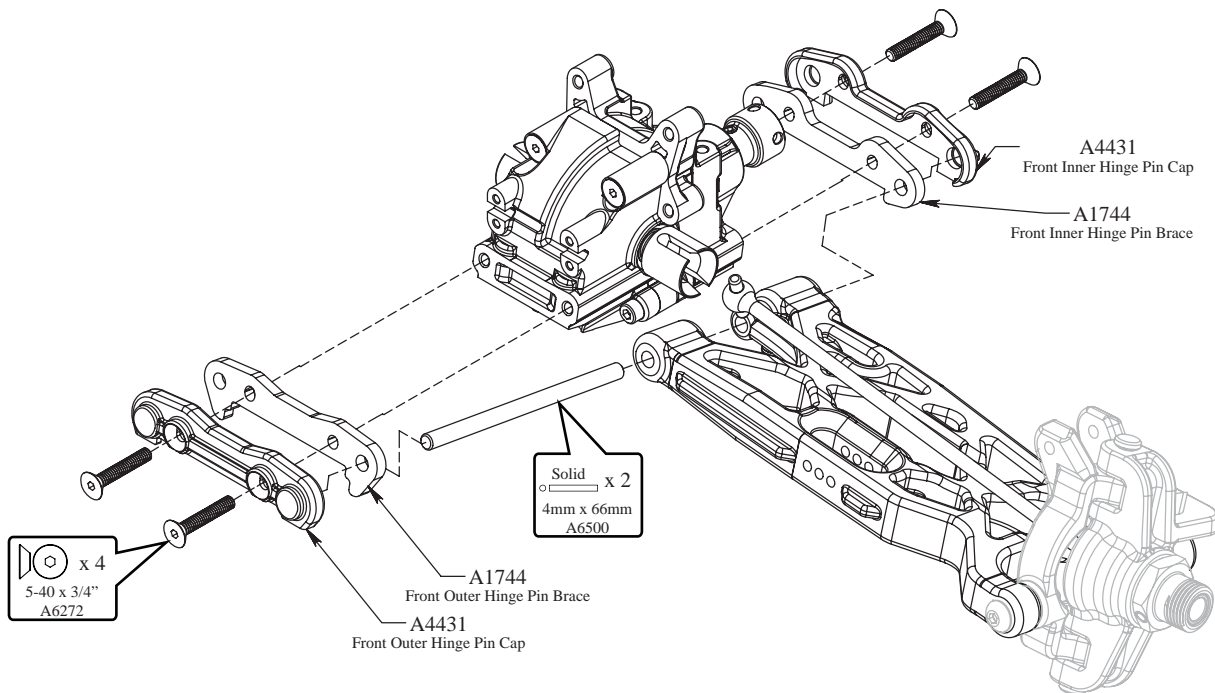

STEP B-08

Swaybar Assembly

Install the Swaybar Ball onto the Swaybar Wire until the end of the wire is flush with the ball as pictured above

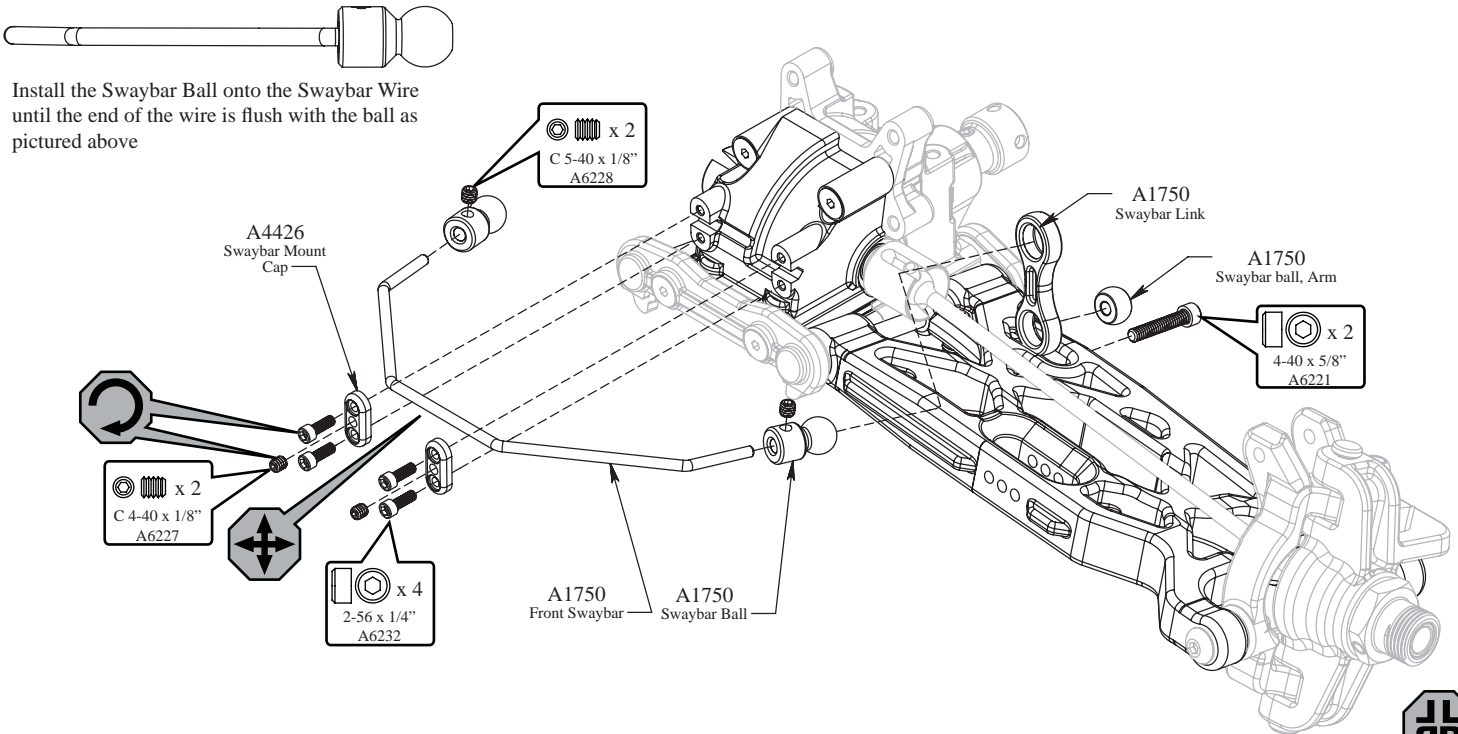

STEP B-09

Tie Rod/Shock Tower Assembly

Be sure to install the assembled Tierod onto the car with the groove (next to the center square section) on the driver's left side for easier adjustment later.

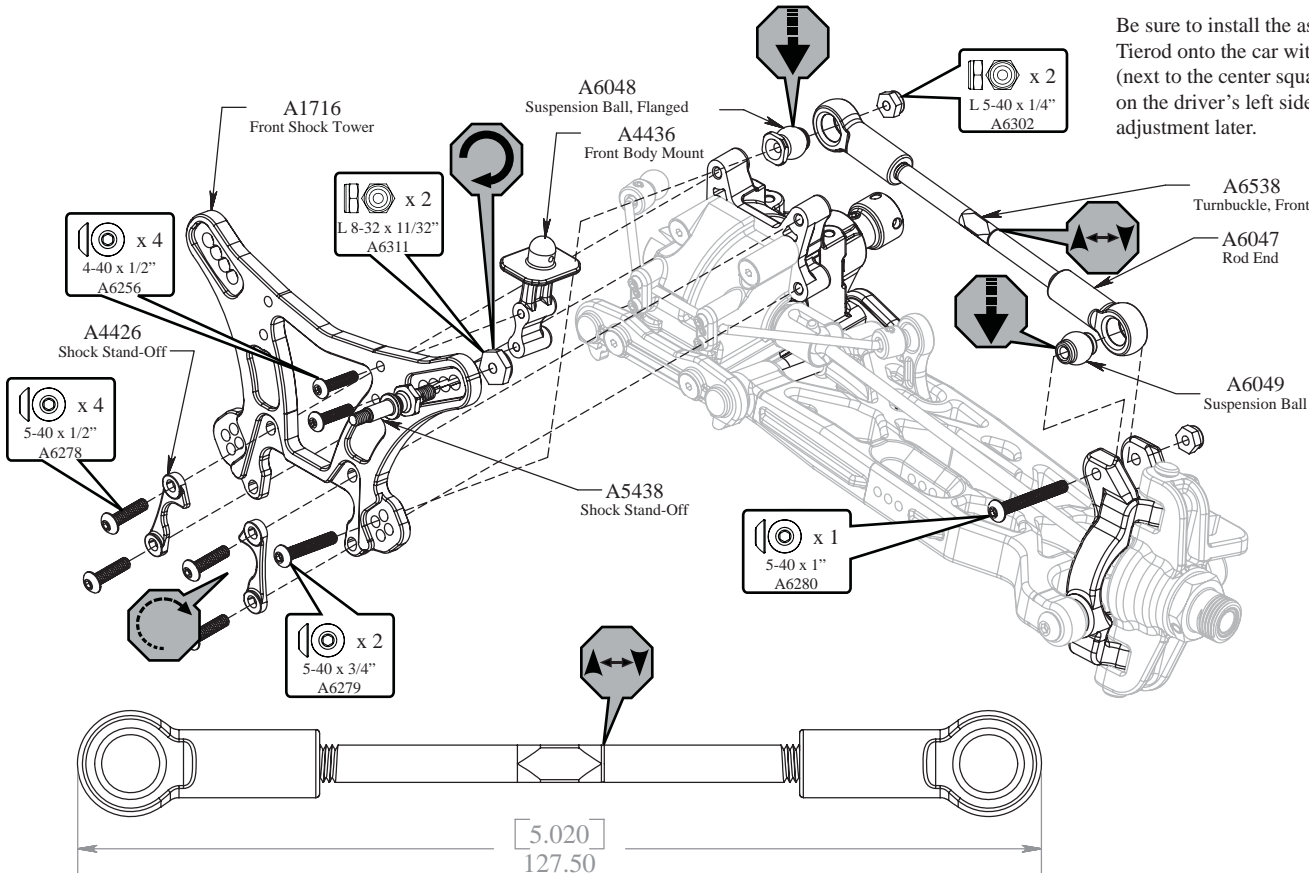

STEP B-10

Front Steering Link Assembly

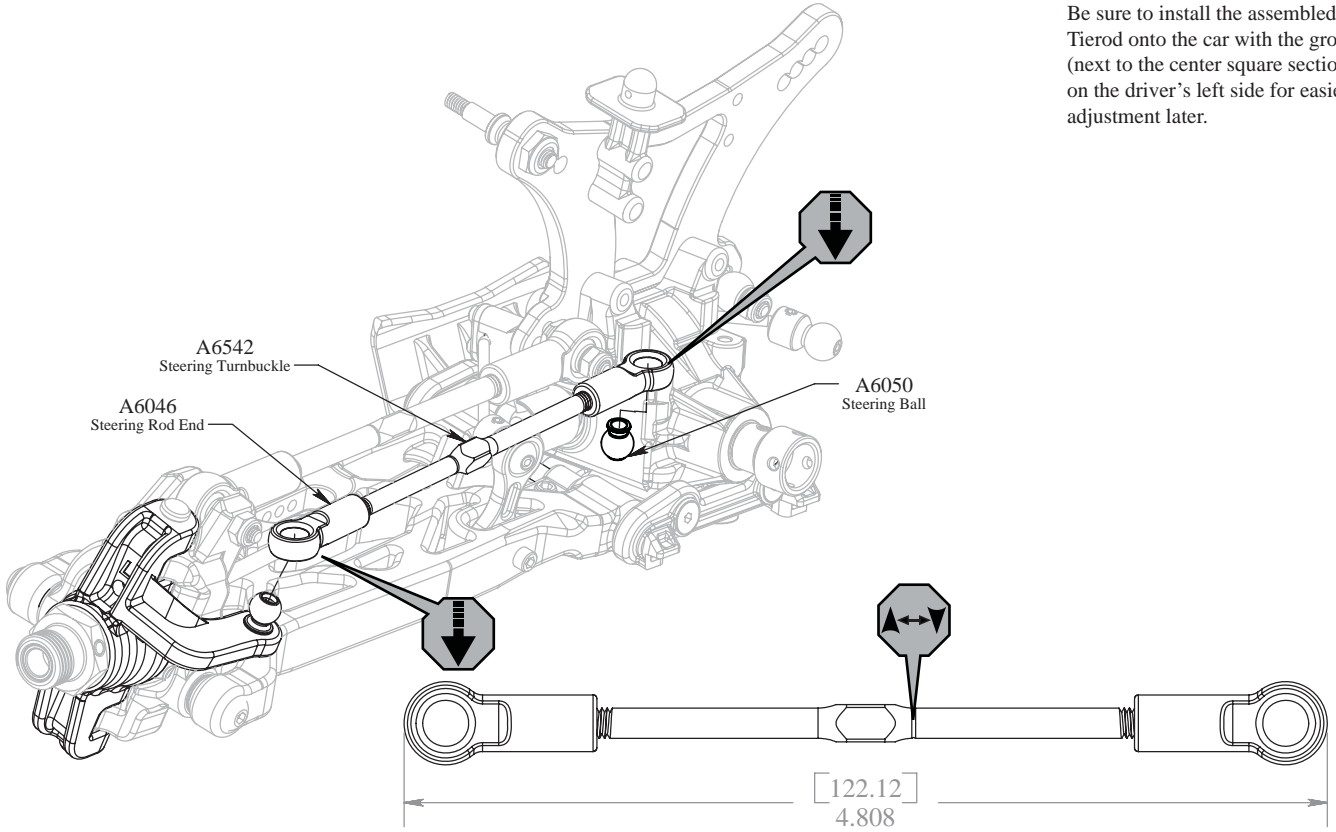

Be sure to install the assembled Tierod onto the car with the groove (next to the center square section) on the driver's left side for easier adjustment later.

STEP B-11

Center CV Assembly

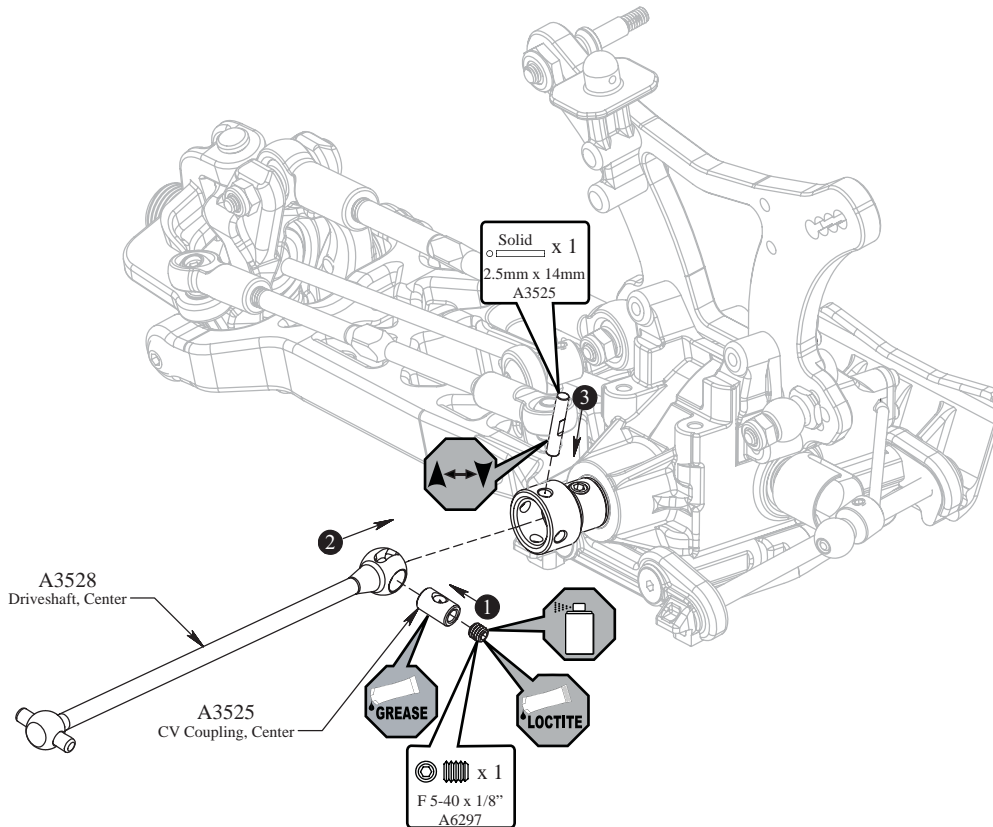

STEP B-12

Front Clip Assembly

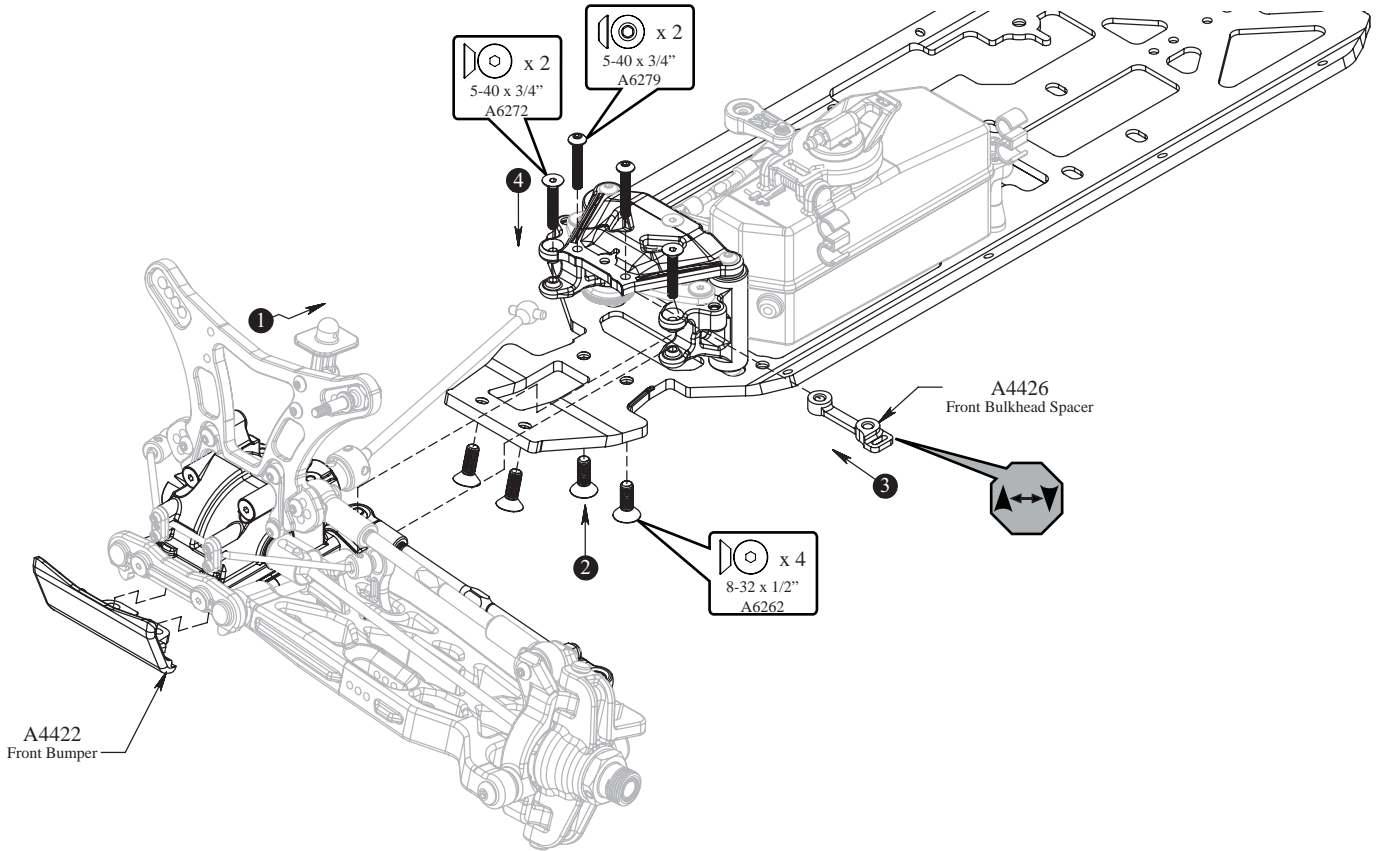

STEP B-13

Completed Front Assembly

