

Name: <u>8 2.0 Race Roller Vehicle Setup</u>		Date: _____	Event: _____
City: _____	State: _____	Track: _____	
Track <input type="checkbox"/> Indoor <input type="checkbox"/> Tight <input type="checkbox"/> Smooth <input type="checkbox"/> Hard Packed <input type="checkbox"/> Blue Groove <input type="checkbox"/> Wet <input type="checkbox"/> Low Bite <input type="checkbox"/> High Bite Conditions <input type="checkbox"/> Outdoor <input type="checkbox"/> Open <input type="checkbox"/> Rough <input type="checkbox"/> Loose/Loamy <input type="checkbox"/> Dry <input type="checkbox"/> Dusty <input type="checkbox"/> Med Bite <input type="checkbox"/> Other _____			

Front Suspension

Toe: 2 degrees of toe-out

Ride Height: 27mm

Camber: -1 degree

Caster: Stock (20 degrees)

Sway Bar: 2.3mm

Piston/Oil: 54/40 wt Losi

Spring: Silver 4.4 lbs

Limiter/Droop: 95mm

Overall Shock Length: 95mm

Steering Ackerman: Long

Bump Steer: Down

Camber Link: 2/B

Shock Location: 2/Inside

Receiver Battery Type: Losi LiPo

Differentials

Front: Standard Smart

Spring Wire Dia: _____

Qty of Springs: _____

Ramp Plate: _____

Grease: _____

Diff Fluid: 5000 wt Losi

Center: Standard Smart

Spring Wire Dia: _____

Qty of Springs: _____

Ramp Plate: _____

Grease: _____

Diff Fluid: 5000 wt Losi

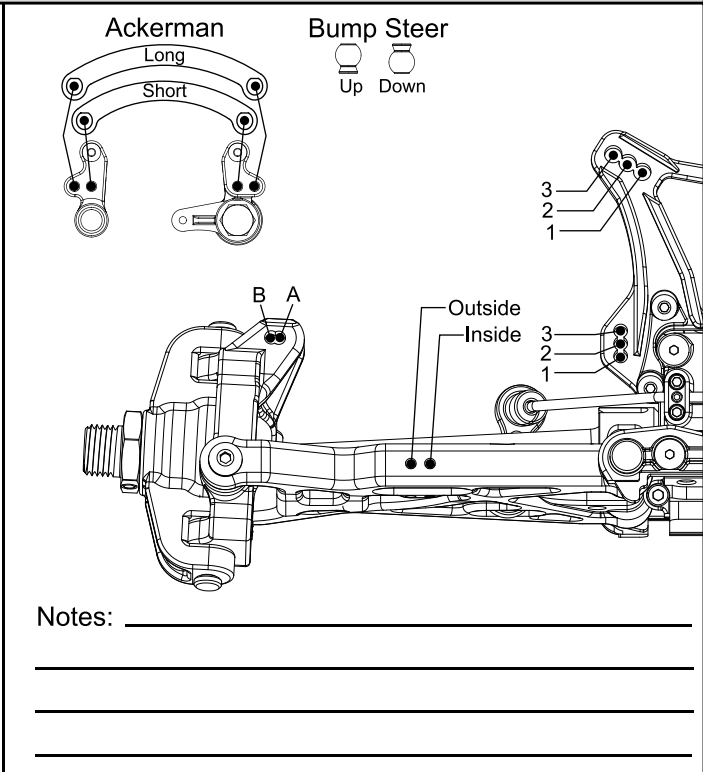

Rear Suspension

Toe: 3 degrees

Anti-Squat: 3 degrees

Ride Height: 29mm

Camber: -2 degrees

Rear Hub Spacing: Back

Sway Bar: 2.3mm

Piston/Oil: 56/25 wt Losi

Spring: Green 3.1lbs

Limiter/Droop: 106mm

Overall Shock Length: 106mm

Camber Link: 2/B

Shock Location: 2/Inside

Rear Diff Fluid: 2000wt Losi

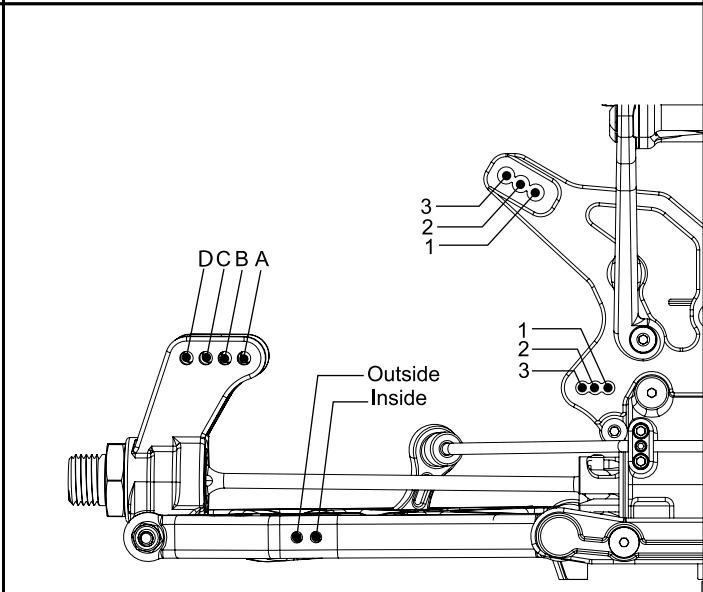

Engine

Engine: _____ Fuel: Nitrotane 30%

Glow Plug: _____ Head Clearance: _____

Pipe/Header: _____ Gearing: 13/48

Clutch

Clutch Shoes and Springs Info

2 Composite with Green Springs

2 Aluminum with Gold Springs

Aluminum Flywheel

Tires

	Type	Compound	Insert
Front:	<u>XBT</u>	<u>Blue</u>	<u>Losi</u>
Rear:	<u>XBT</u>	<u>Blue</u>	<u>Losi</u>
Notes:	_____		



A Division of Horizon Hobby, Inc.
4710 E. Guasti Road
Ontario, CA 91761
Phone - 909-390-9595
Fax - 909-390-5356
WWW.LOSI.COM
E-mail - feedback@losi.com

EIGHT 2.0

1/8-SCALE 4WD COMPETITION NITRO BUGGY RACE ROLLER

OWNER'S MANUAL



Welcome Team Losi Racing 8IGHT 2.0 Owner!

Thank you for selecting the 8IGHT 2.0 as your new racing buggy. The 8IGHT 2.0 has already distinguished itself as a top caliber racing chassis and as you will see, we have made every effort to produce a vehicle that is not only the most competitive but also easy to maintain. The simple step-by-step assembly sequence and easily followed instructions and drawings combined with Team Losi Racing's world famous quality fitting parts will make using the 8IGHT 2.0 a most enjoyable vehicle.

Please take a moment to read through the following instructions. This will familiarize you with the various parts, assembly tips and descriptions as well as the tools needed. Taking an extra moment before using your vehicle will help you understand the dynamics of the 8IGHT 2.0 and setup tips to ensure the best possible experience.

Good luck and good racing,

Team Losi Racing

Register your Losi Product Online:

Register your 8IGHT 2.0 now and be the first to find out about the latest options parts, product updates and more. Log on to www.LOSI.com and follow the product registration link to stay connected.

8IGHT 2.0 COMPLETED KIT SPECIFICATIONS

Overall Chassis Length: 16.35" (415mm)	Wheelbase: 12.71"-12.87" (323-327mm)	*Front Track Width: 12.13" (308mm)
Overall Length w/Tires: 19.5" (497mm)	*Overall Height: 6.625" (168mm)	*Rear Track Width: 12.13" (308mm)

Note: Final vehicle weight will vary depending on accessories used.

**All measurements taken at ride height (32mm).*

Table 1: 8IGHT 2.0 Completed Vehicle Specifications.

Vehicle/Manual Organization:

The vehicle is composed of different steps marked A through H. Each step contains all of the parts necessary to complete a particular section of the vehicle. Some of these steps have sub-assembly steps within them. It is helpful to read through the instructions for an entire step prior to working on your vehicle. Next to each of the step numbers is a check box. At the completion of each step, place a check in this box so that if you must stop and come back to the assembly, you will be able to pick up where you left off.

For your convenience, an actual-size Hardware Identification Guide is included as a fold-out page at the back of this manual. Hardware that is not easily differentiable in each step is called out with an icon which contains a small picture of the part genre (referenced on the Hardware Identification Guide), the quantity of that part required for what is shown in the step, and the size or name of that part. To check a part, hold it against the silhouette until the correct part is identified. Associated with each of these parts, in the Hardware Identification Guide, is an LOSA-Number which is used when ordering replacement parts for your 8IGHT 2.0. In some cases, extra hardware has been supplied for parts that may be easy to lose.

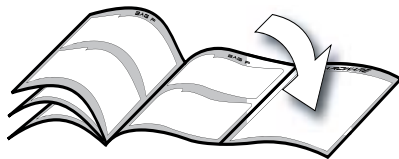

Components used in each step are identified by their relative LOSA-Number and the component's name. With the exception of a few parts, these are not referenced in the Hardware Identification Guide.

The molded parts in Team Losi Racing vehicles are manufactured to demanding tolerances. When screws are tightened to the point of being snug, the parts are held firmly in place. For this reason, it is very important that screws not be overtightened in any of the plastic parts.

In some steps there will be a filled black circle with a white number. These indicate the specific order by which assembly must occur. In cases

where steps are repeated (front/rear or left/right) these numbers may be omitted. Please note that these numbers will not call out every sub-step required for the step's assembly procedures, they will only highlight the critical order required for assembly.

In each step, there are specific "Detail Icons" (shaped like a stop sign) that call out critical precautions or assembly tips for the process. There is a reference key that describes the meaning of each of the icons located on the fold-out Hardware Identification Guide at the back of this manual.

To ensure that parts are not lost during construction, it is recommended that you work over a towel or mat to prevent parts from rolling away.

IMPORTANT SAFETY NOTES:

1. Select an area for assembly that is away from the reach of small children. *Some parts in this vehicle are small and can be swallowed by children, causing choking and possible internal injury; PLEASE USE CAUTION!*
2. The shock fluid and greases supplied should be kept out of children's reach. *They are not intended for human consumption!*
3. Exercise care when using any hand tools, sharp instruments, or power tools during construction.
4. Carefully read all manufacturer's warnings and cautions for any chemicals, glues, or paints that may be used for assembly and operating purposes.

Name: _____	Date: _____ Event: _____
City: _____ State: _____	Track: _____
Track <input type="checkbox"/> Indoor <input type="checkbox"/> Tight <input type="checkbox"/> Smooth <input type="checkbox"/> Hard Packed <input type="checkbox"/> Blue Groove <input type="checkbox"/> Wet <input type="checkbox"/> Low Bite <input type="checkbox"/> High Bite Conditions <input type="checkbox"/> Outdoor <input type="checkbox"/> Open <input type="checkbox"/> Rough <input type="checkbox"/> Loose/Loamy <input type="checkbox"/> Dry <input type="checkbox"/> Dusty <input type="checkbox"/> Med Bite <input type="checkbox"/> Other _____	

Front Suspension

Toe: _____
 Ride Height: _____
 Camber: _____
 Caster: _____
 Sway Bar: _____
 Piston/Oil: _____
 Spring: _____
 Limiter/Droop: _____
 Overall Shock Length: _____
 Steering Ackerman: _____
 Bump Steer: _____
 Camber Link: _____
 Shock Location: _____
 Receiver Battery Type: _____

Differentials

Front: Standard Smart
 Spring Wire Dia: _____
 Qty of Springs: _____
 Ramp Plate: _____
 Grease: _____
 Diff Fluid: _____
 Center: Standard Smart
 Spring Wire Dia: _____
 Qty of Springs: _____
 Ramp Plate: _____
 Grease: _____
 Diff Fluid: _____

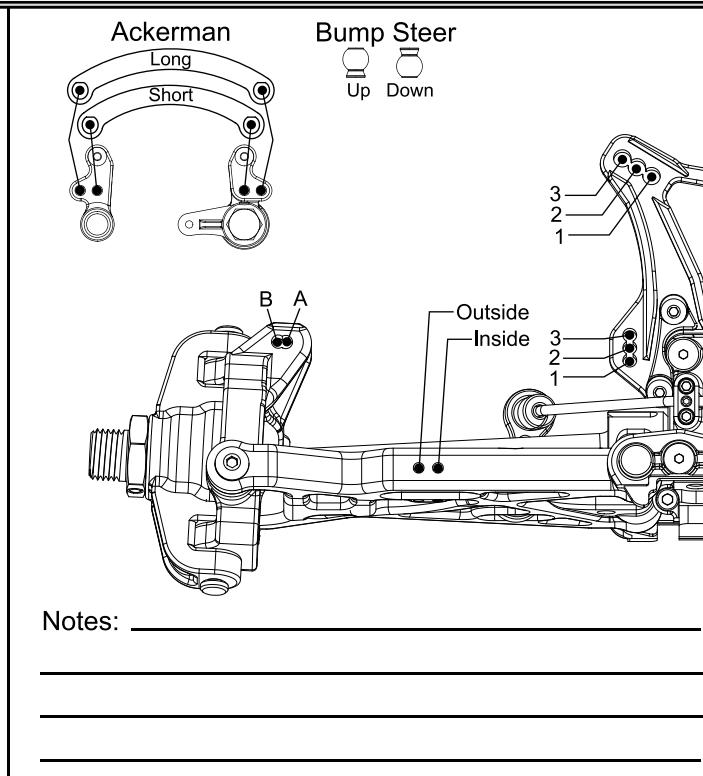

Rear Suspension

Toe: _____
 Anti-Squat: _____
 Ride Height: _____
 Camber: _____
 Rear Hub Spacing: _____
 Sway Bar: _____
 Piston/Oil: _____
 Spring: _____
 Limiter/Droop: _____
 Overall Shock Length: _____
 Camber Link: _____
 Shock Location: _____
 Rear Diff Fluid: _____

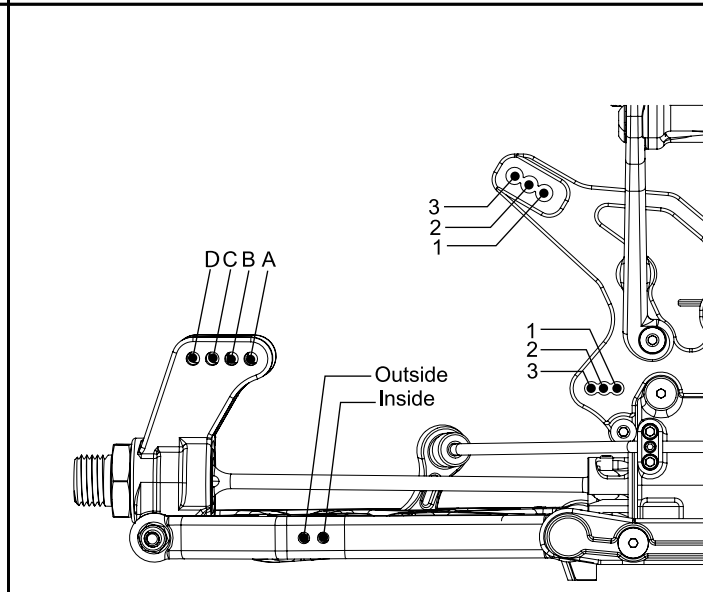

Engine

Engine: _____ Fuel: _____
 Glow Plug: _____ Head Clearance: _____
 Pipe/Header: _____ Gearing: _____

Clutch

Clutch Shoes and Springs Info

Tires

Type	Compound	Insert
Front: _____	_____	_____
Rear: _____	_____	_____
Notes: _____		

Cap Head

- 2-56 x 1/4" (A6232)
- 2-56 x 1/2" (A6254)
- 4-40 x 3/8" (A6206)
- 4-40 x 1/2" (A6204)
- 4-40 x 5/8" (A6221)
- 5-40 x 1/2" (A6240)
- 5-40 x 7/8" w/ 5/8" Shoulder (A4414)

Flat Head 1

- 3 x 8mm (A9106)
- 3 x 12mm (A3500)
- 5-40 x 3/8" (A6270)
- 5-40 x 1/2" (A6271)
- 5-40 x 5/8" (A6275)
- 5-40 x 3/4" (A6272)
- 5-40 x 7/8" (A6273)

Flat Head 2

- 8-32 x 3/8" (A6264)
- 8-32 x 1/2" (A6262)
- 5-40 x 1-7/8" (A6273)

Button Head

- 2-56 x 1/4" (A6255)
- 4-40 x 1/4" (A6234)
- 4-40 x 1/2" (A6256)
- 5-40 x 3/8" (A6277)
- 5-40 x 1/2" (A6278)
- 5-40 x 20mm (A6281)
- 5-40 x 3/4" (A6279)
- 5-40 x 1" (A6280)
- 8-32 x 3/4" (A6263)

Set

- F 5-40 x 1/8" (A6228)
- C 4-40 x 1/8" (A6227)
- C 5-40 x 3/16" (A6299)
- C 8-32 x 1/8" (A6298)
- F 5-40 x 1/8" (A6297)
- F 8-32 x 1/8" (A6296)
- O10-32 x 3/8" (A6295)
- 5-40 x 22mm (A6045)

Ball Bearings 1

- 5x10x4mm (A6949)
- 6x10x3mm (A6946)
- 5x11x4mm (A6947)
- F 5x11x4mm (A6948)

Ball Bearings 2

- 5x13x4mm (A6949)
- 8x14x4mm (A6945)
- 1/2" x 3/4" (A6953)

Pins

- 2.5 x 14mm (A3526)
- 2.5 x 12.37mm (A3523)
- 3 x 17mm (A3531)
- 2.5 x 12.8mm (A3505)
- 4 x 66mm (A6500)
- 3.5 x 53mm (A6503)

Washers

- Ball Stud (A6215)
- #4 x .030" (A6350)
- .250 x .094 x .020" (A9166)

Shims

- 5x7x.2mm (A9104)
- 6x11x.2mm (A3501)
- 14x17x.1mm (A4452)
- 14x17x.25mm (A4452)

Retaining Clips

- 5mm E-clip (A6109)
- Body Clip (A8200)

Nuts (Lock/Plain)

- #4-40 (Mini) (A6306)
- #5-40 (A6302)
- #8-32 (A6311)

DETAIL ICON REFERENCE KEY

1 These numbers are used to identify the critical order in which assembly must occur. *Note: They will not call out every stage of the assembly process.

Apply Losi-Lok®	Apply Clear Grease	Apply CA Glue	Degrease with Motor Spray	Fill With Silicone Oil	Pre-Tap
Pay Special Attention	Cut/Trim	Ensure Free Movement	Ensure Free Rotation	Ensure Proper Orientation	Push Firm
Side Shown	Assemble Other Side the Same	Repeat/Build Multiple	Screw Partially	DO NOT Over Tighten/ Snug Tight	Tighten

TOOLS REQUIRED FOR ASSEMBLY

Team Losi Racing has supplied all necessary Allen wrenches and special wrenches that are needed for assembly and adjustments. The following common tools will also be required: needle-nose pliers, regular pliers, hobby knife, scissors or other body cutting/trimming tools, and a soldering iron may be necessary for radio installation. 3/16", 1/4", 5/16" and 11/32" nut drivers are optional.

RADIO/ELECTRONICS

A suggested radio layout is provided in this manual. Your high-performance RC center should be consulted regarding specific questions pertaining to radio/electrical equipment.

HARDWARE IDENTIFICATION

When in question, use the Hardware Identification Guide at the back of this manual.

- For screws, the prefix number designates the thread size and number of threads per inch (e.g., 4-40 is a #4 size thread with 40 threads per inch). The second number, or fraction, designates the length of the screw. For cap head and button head screws, this number refers to the length of the threaded portion of the screw. For flat head and setscrews, this number refers to the overall length of the screw.
- Bearings and bushings are referenced by the inside diameter (I.D.) x outside diameter (O.D.).
- Shafts and pins are designated by type (Roll, Solid) and referenced by diameter x length.
- Washers, Spacers and Shims are described by inside diameter or the screw size that will pass through the inside diameter x the thickness or by their designated application (e.g., Ball Stud washer is primarily used under a Ball Stud).
- Retaining Clips are sized by the shaft diameter that they attach to or by type (Body). The Hardware Icon associated with E/C-clips only designates the part genre of clips, not the actual part.
- Nuts come in four types, Non-Flanged, Flanged (F), Plain and Locking (L) (designated on the Hardware Icons). The prefix number designates the thread size and number of threads per inch. The second number, or fraction, designates the size of the hex. For example, L 4-40 x 1/4" designates a locknut that will thread onto a 4-40 screw using a 1/4" nut driver.
- Setscrews come in three types, Cup (C), Flat (F) and Oval (O) (designated on the hardware Icons). The prefix number designates the thread size and number of thread per inch. The second number, or fraction, designates the length of the threaded portion of the screw.

TABLE OF CONTENTS

SECTIONS

1. INTRODUCTION.....	i
Vehicle/Manual Organization	i
Important Safety Notes	i
Tools Required for Assembly.....	ii
Radio/Electronics.....	ii
Hardware Identification	ii
2. Step A: Steering Assembly.....	1-2
3. Step B: Front Clip	3-8
4. Step C: Center Transmission.....	9-12
5. Step D: Rear Clip	13-18
6. Step E: Shocks	19-21
7. Step F: Radio Tray	22-26
8. Step G: Engine Installation	27-30
9. Step H: Wheels, Tires, Body	31-35
8. Checklist Before Your First Run	36
9. Setup Guide	37-39
10. Blank 8IGHT Setup Sheet.....	40
11. Hardware Identification Guide.....	41
12. Filled-out 8IGHT 2.0 Vehicle Setup Sheet.....	42

TABLES

Table 1: 8IGHT 2.0 Completed Vehicle Specifications...i
Table 2: Servo Installation 23



Team Losi Racing is continually changing and improving designs; therefore, the actual part may appear slightly different than the illustrated part. Illustrations of parts and assemblies may be slightly distorted to enhance pertinent details.

STEP A-01

Steering Link Assembly

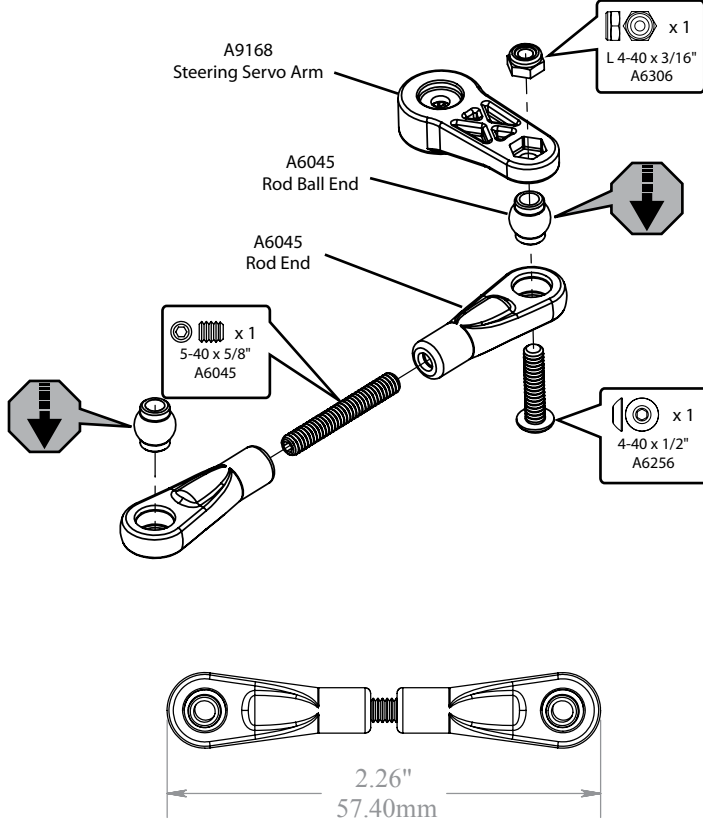

STEP A-02

Servo Saver Assembly

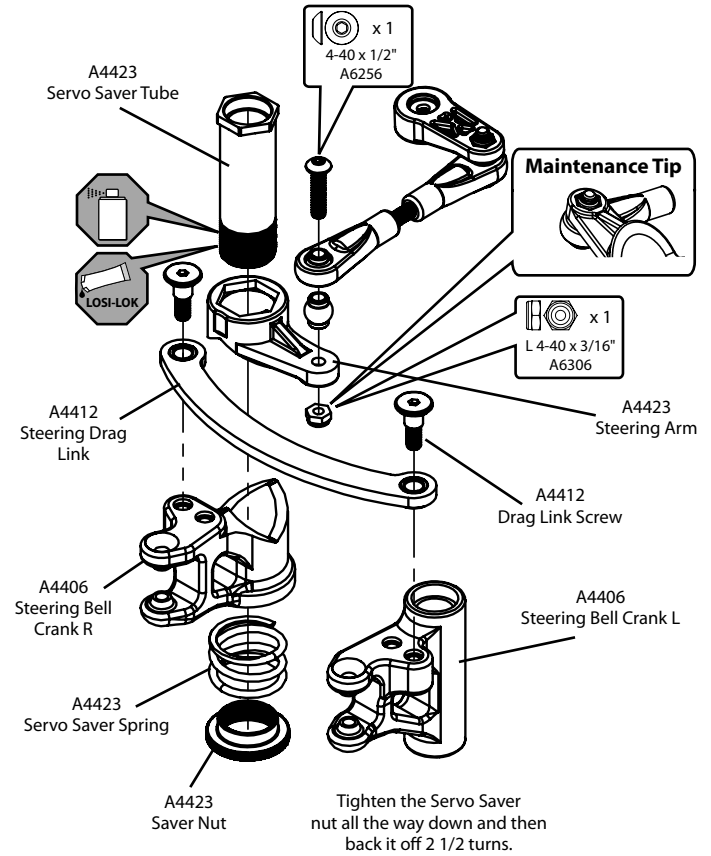

STEP A-03

Fuel Tank/Chassis Brace Assembly

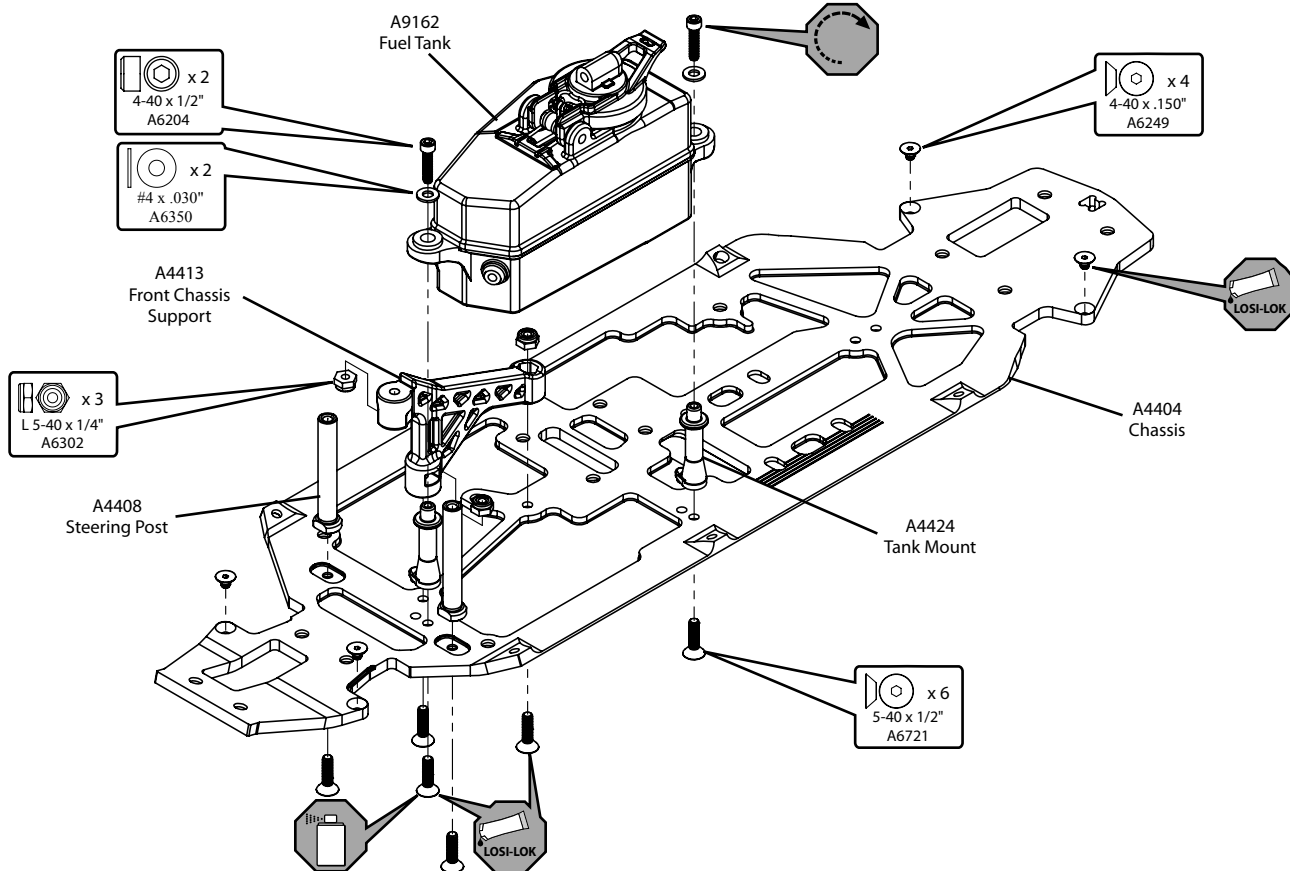

STEP A-04

Steering/Top Plate Assembly

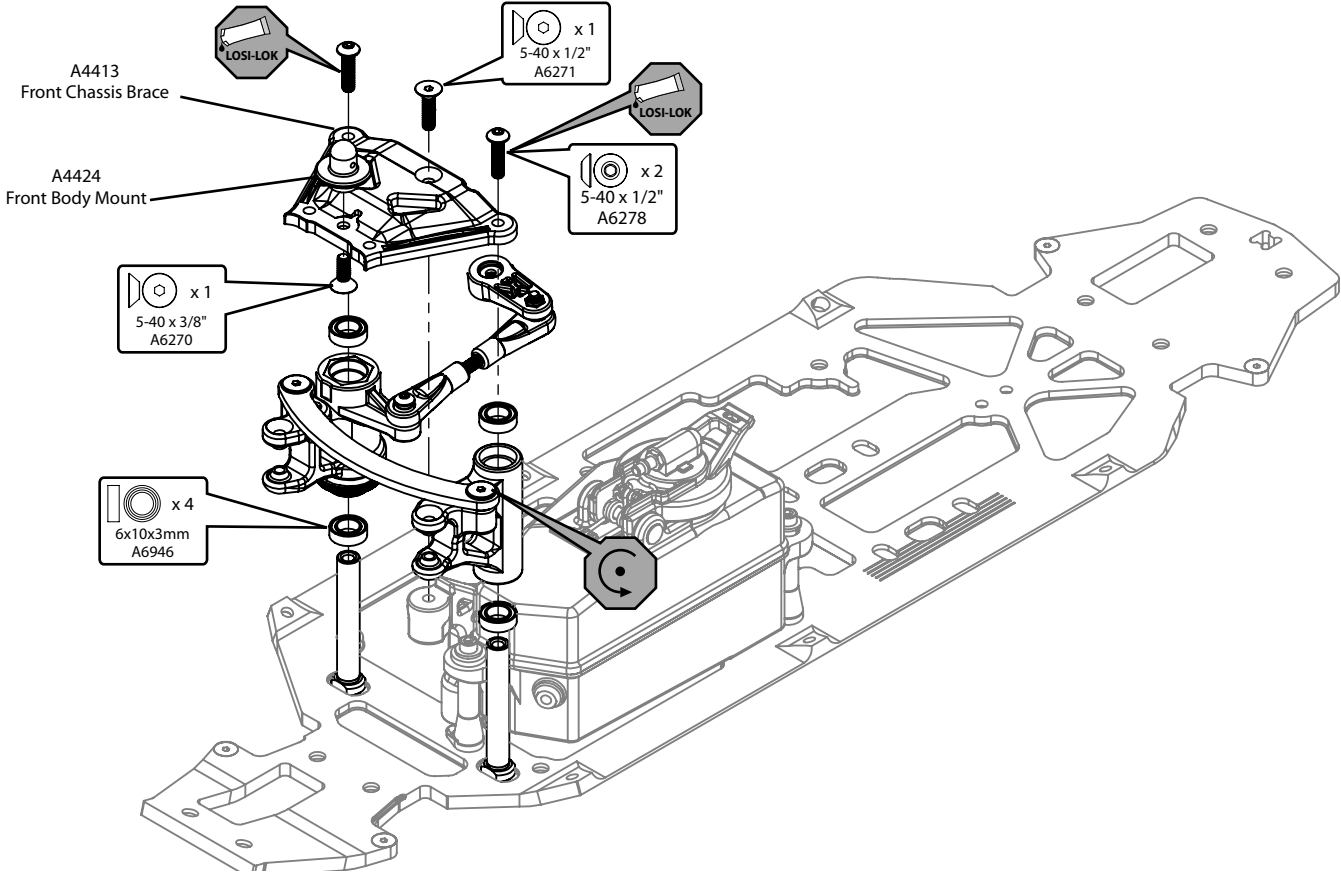

STEP A-05

Completed Steering Assembly

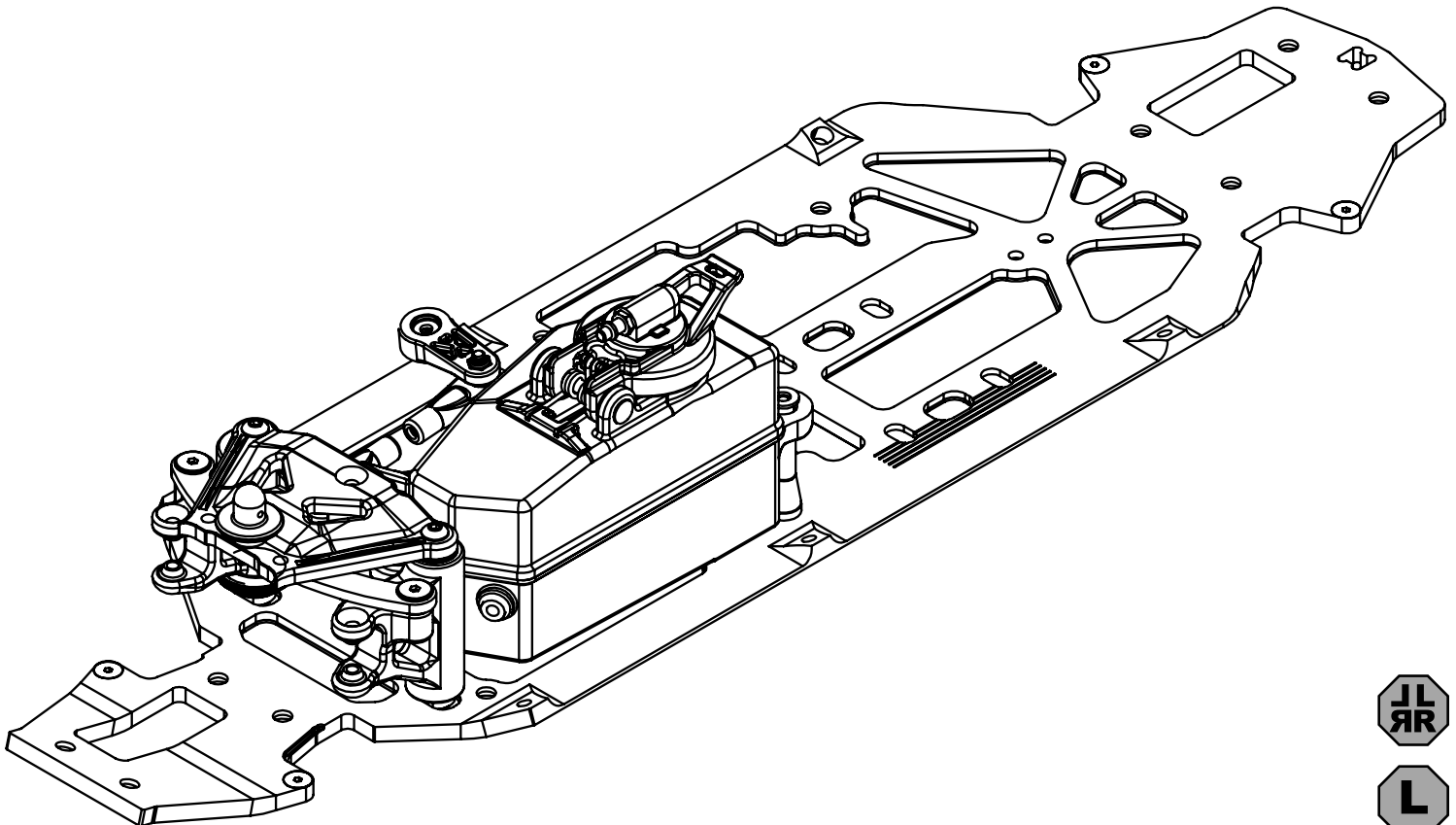

STEP B-01

Ring Gear Assembly

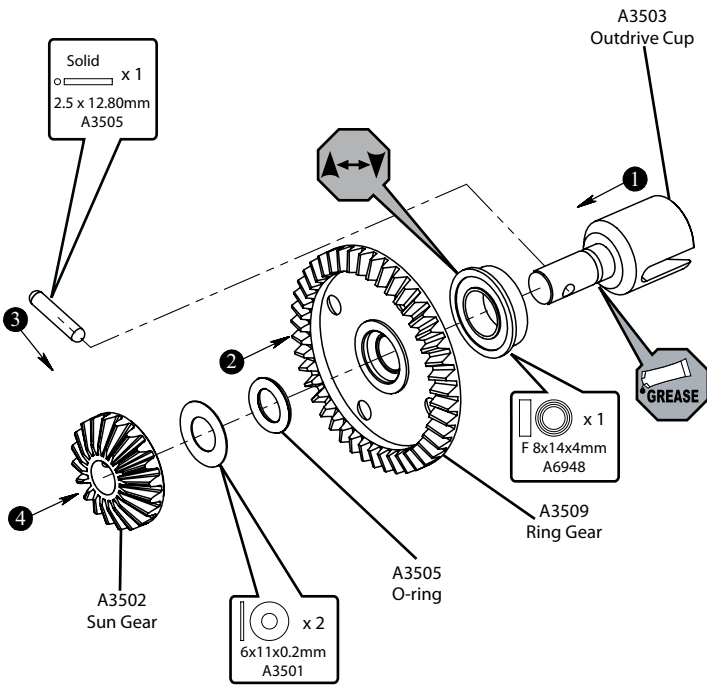

STEP B-03

Complete Diff Assembly

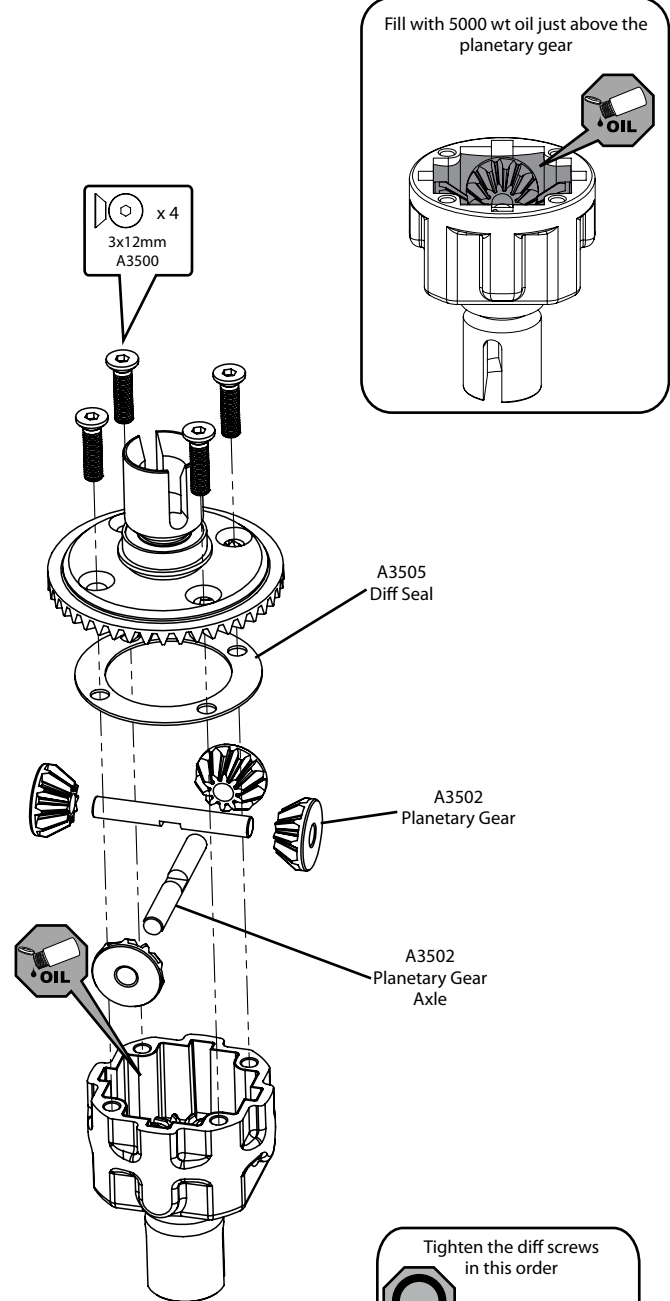

STEP B-02

Diff Case Assembly

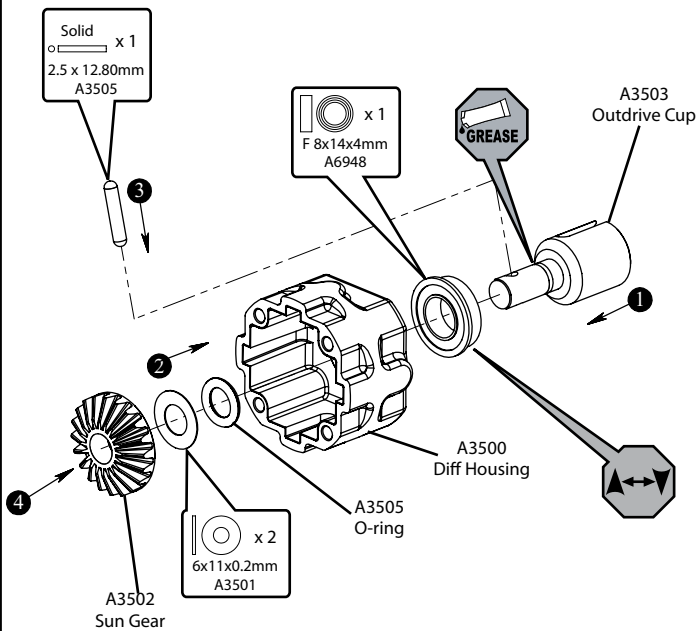

STEP B-04

Front Diff Install

To prevent fine dust from entering the gearbox, apply a thin bead of grease along the edge of the case as pictured.

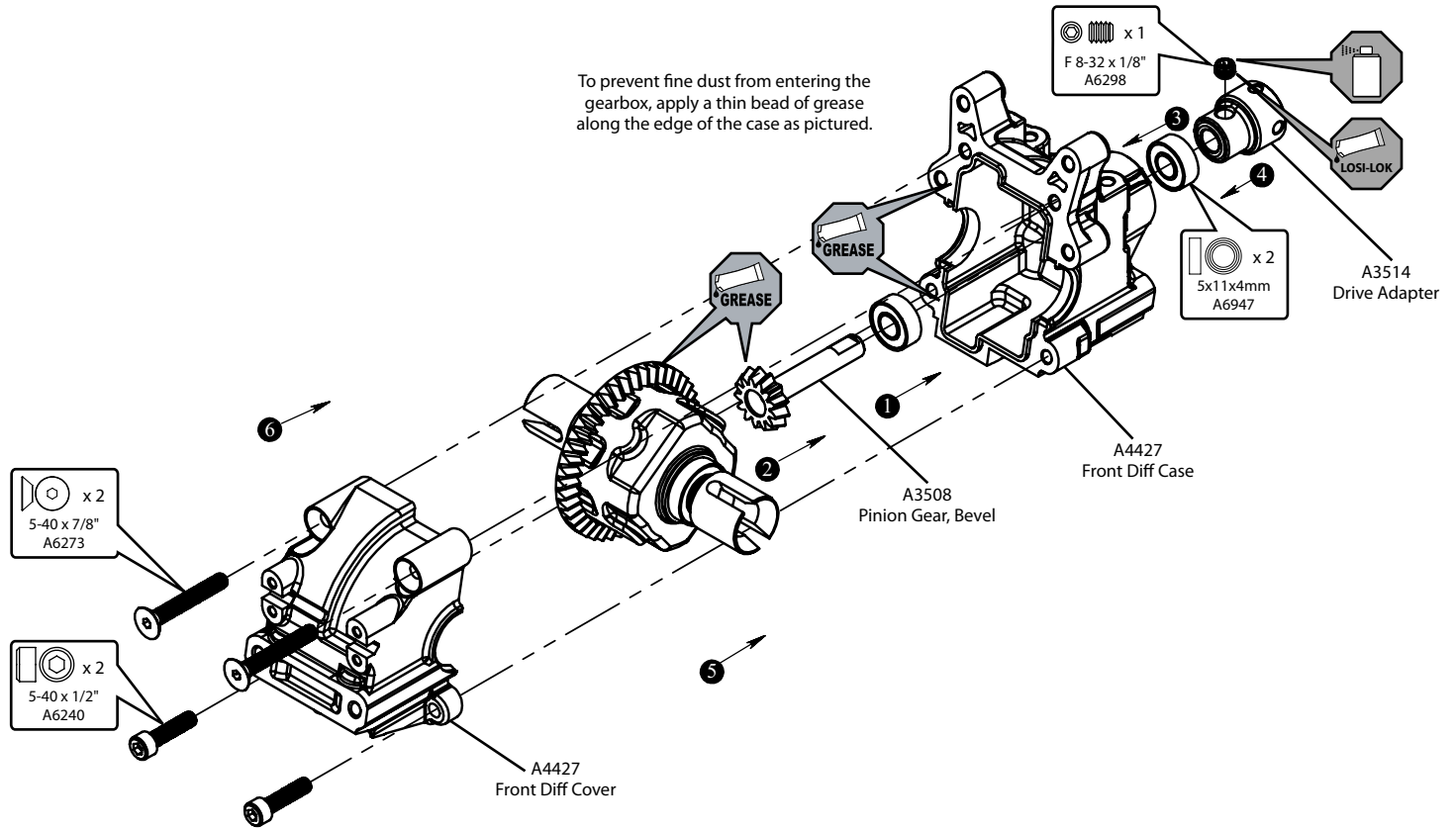

STEP B-05

Front Spindle & CV Assembly

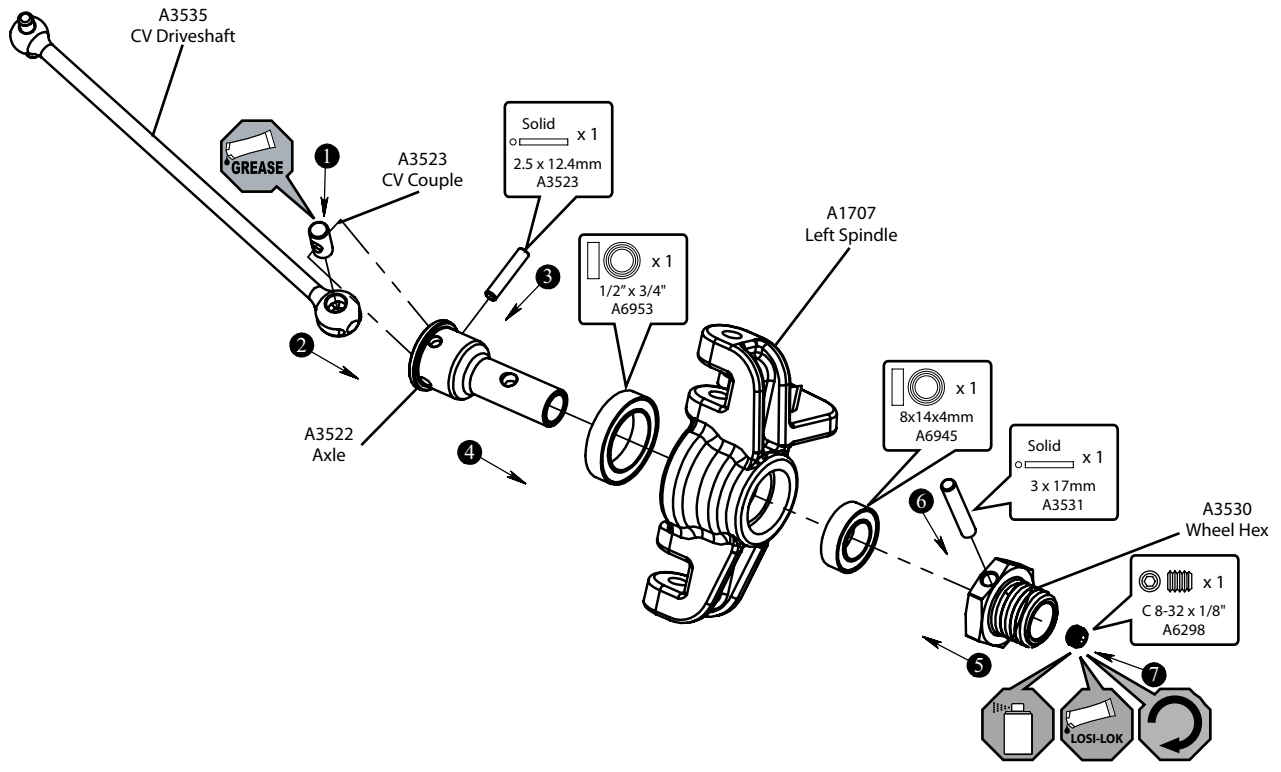

STEP B-06

Spindle/Carrier Assembly

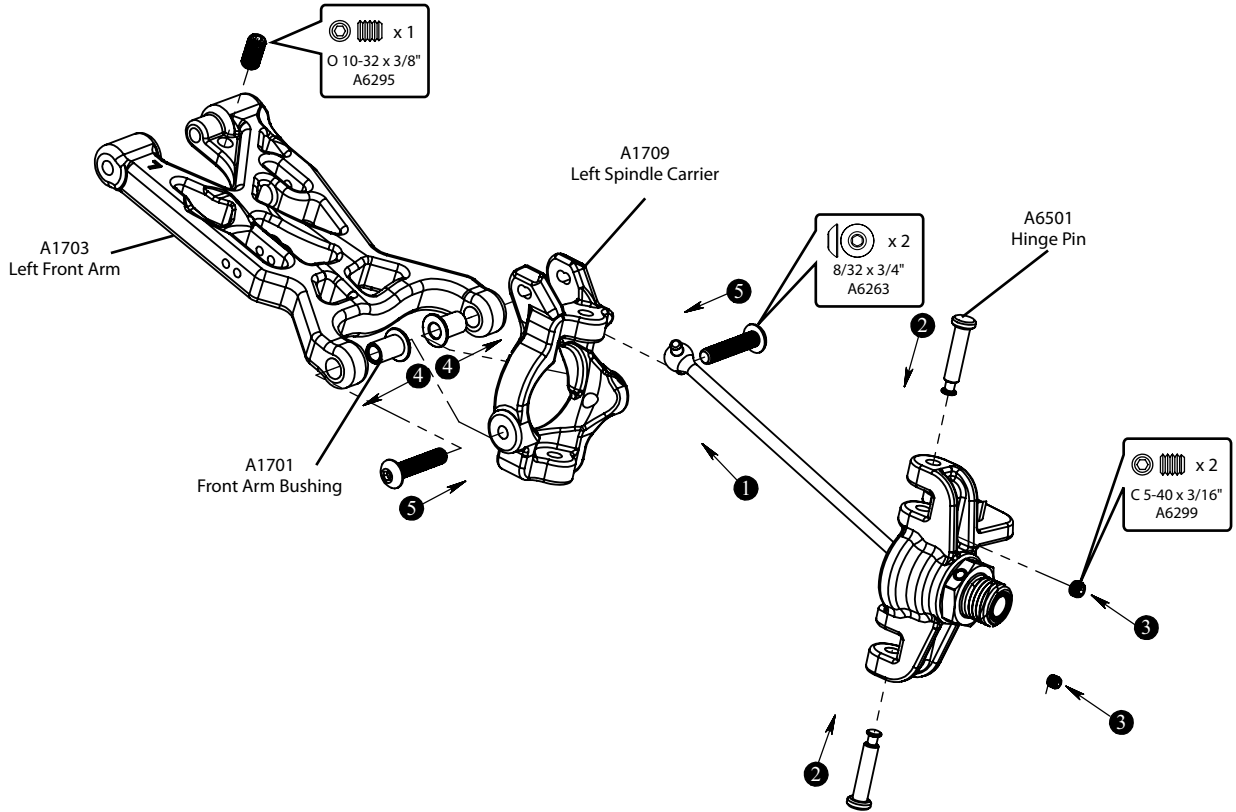

STEP B-07

Front Suspension Arms Assembly

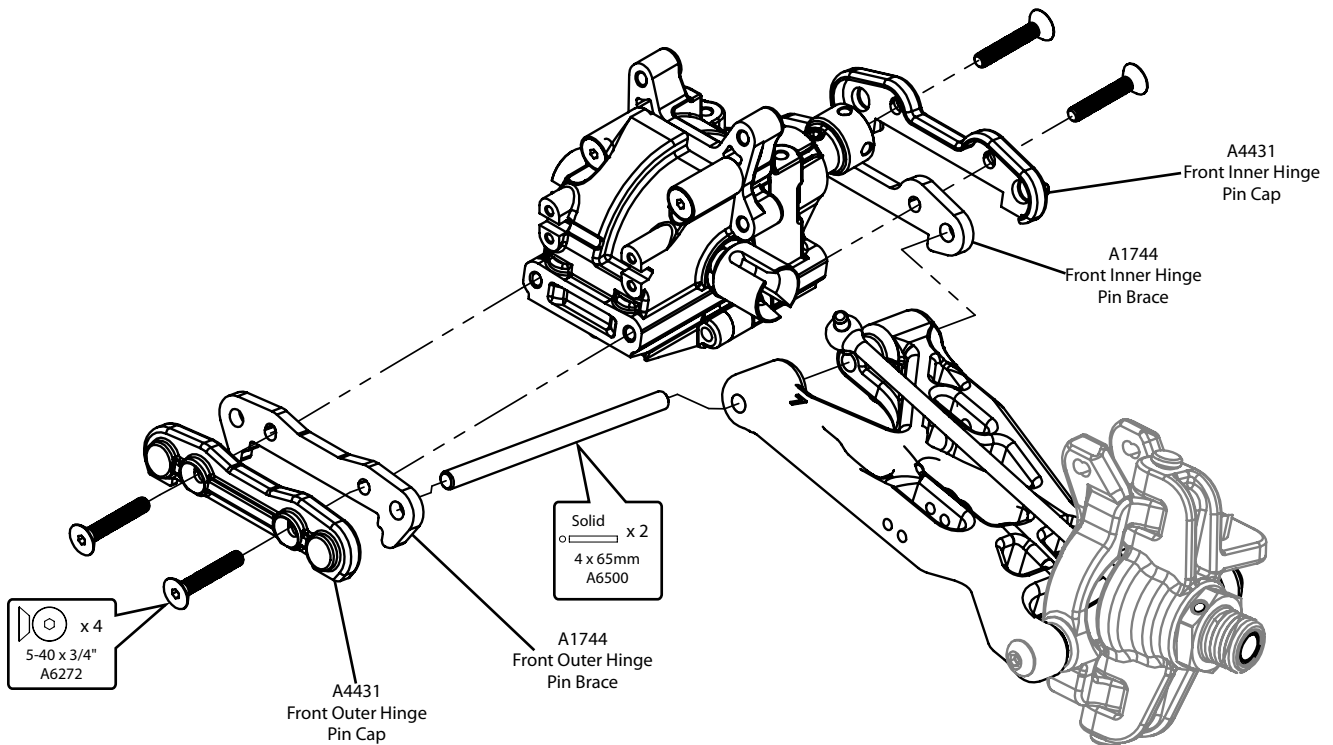

STEP B-08

Sway Bar Assembly

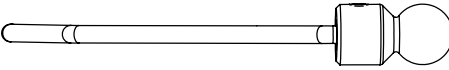

Install the Sway Bar Ball onto the Sway Bar Wire until the end of the wire is flush with the ball as pictured above.

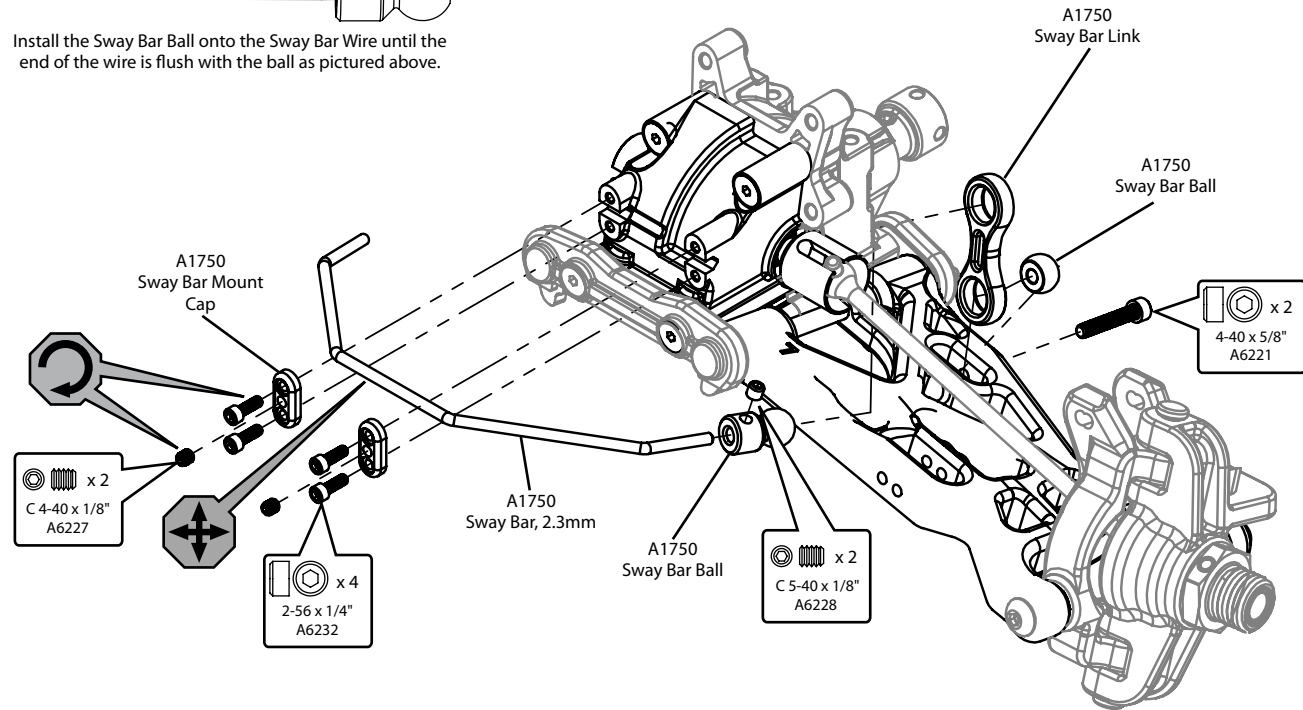

STEP B-09

Tie Rod/Shock Tower Assembly

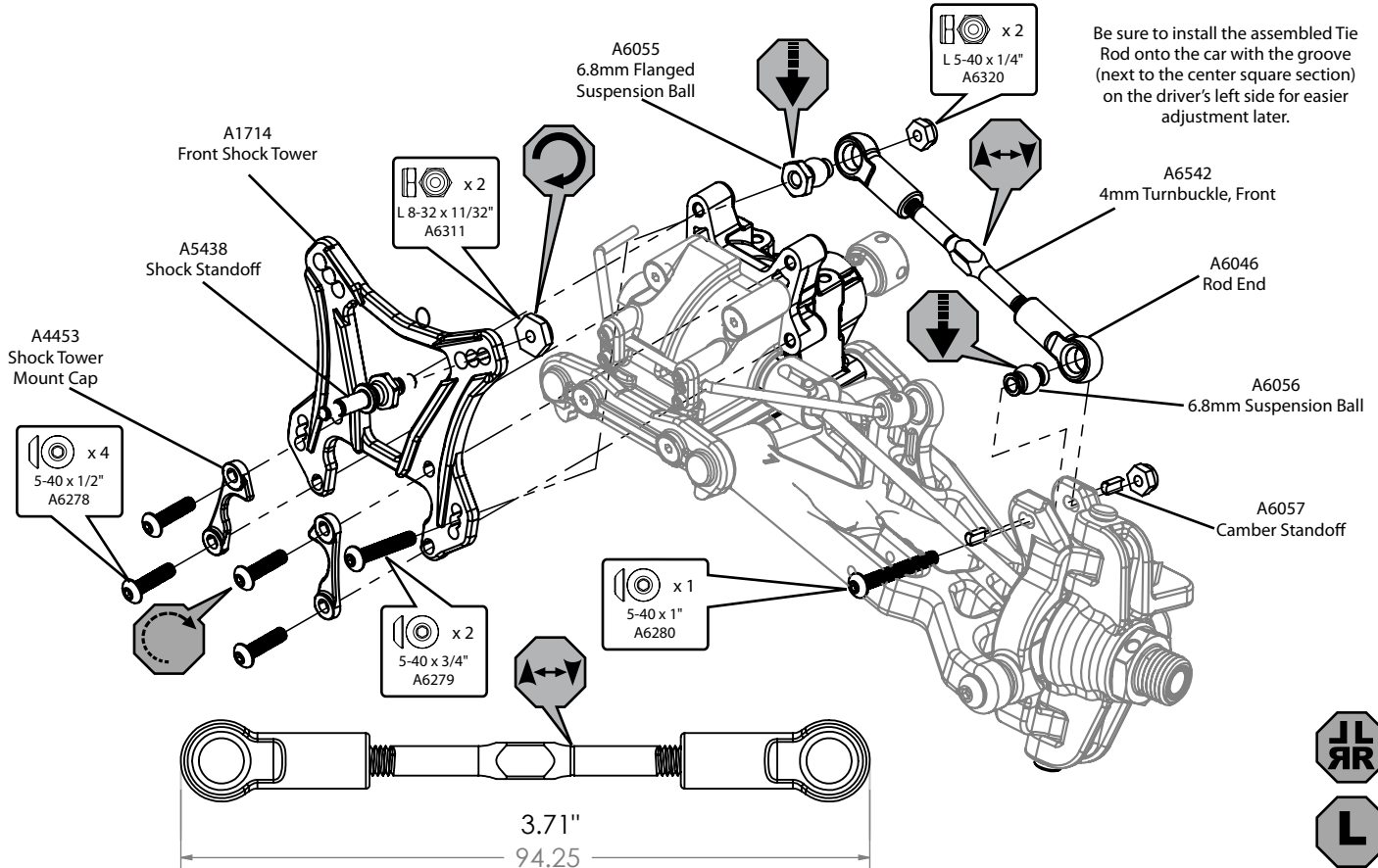

Be sure to install the assembled Tie Rod onto the car with the groove (next to the center square section) on the driver's left side for easier adjustment later.



STEP B-10

Center CV Assembly

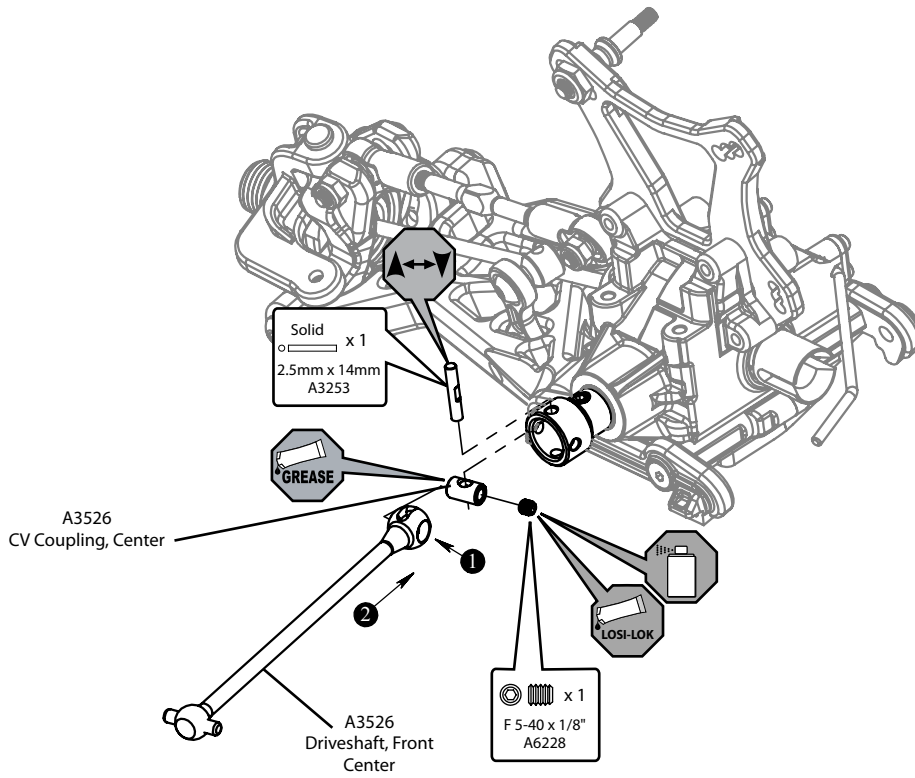

STEP B-11

Steering Rod Assembly

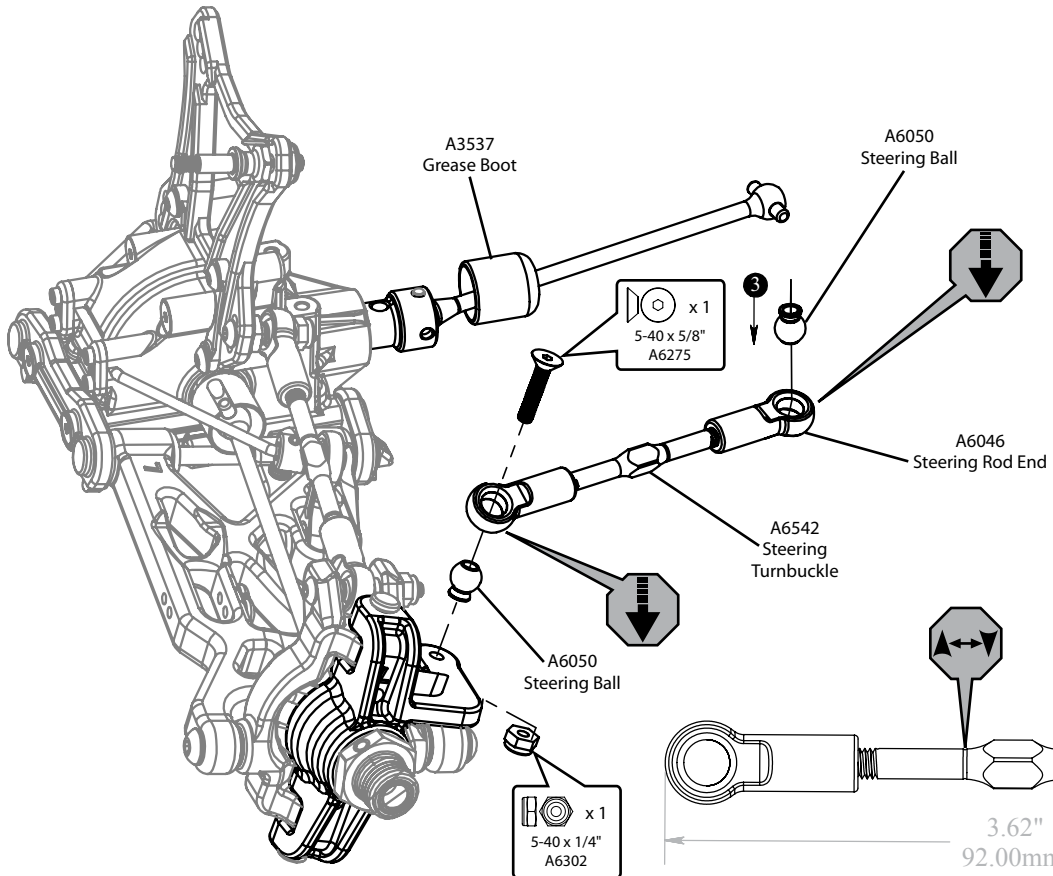

Be sure to install the assembled Tie Rod onto the car with the groove (next to the center square section) on the driver's left side for easier adjustment later.



□ **STEP B-12**

Front Clip Assembly

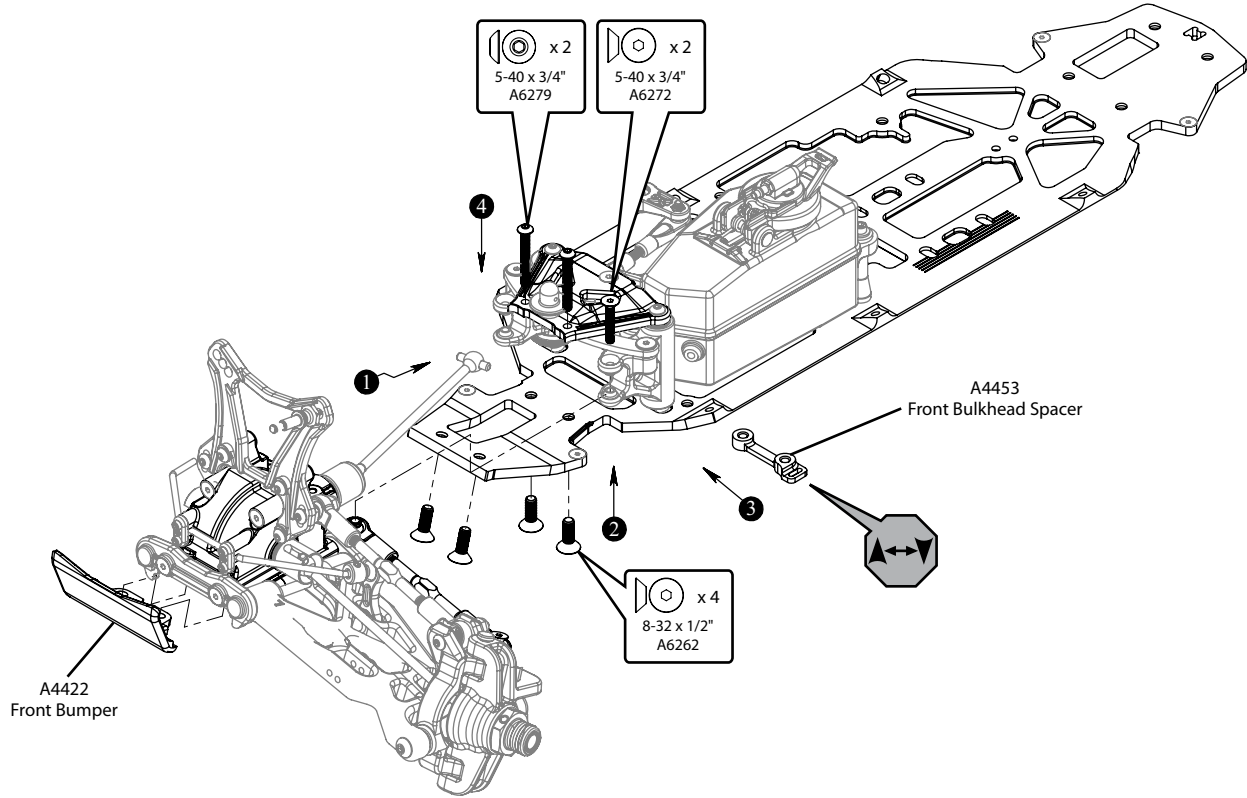

□ **STEP B-13**

Completed Front Assembly

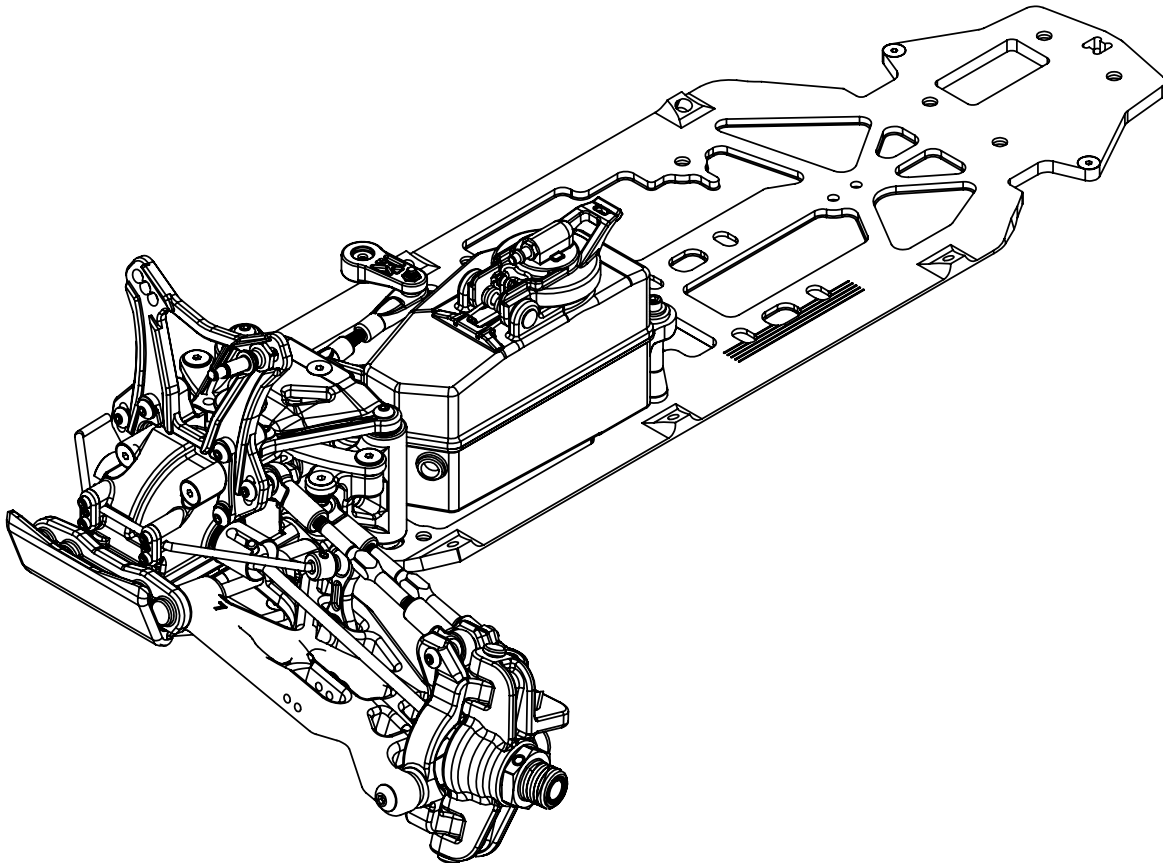

STEP C-01

Ring Gear Assembly

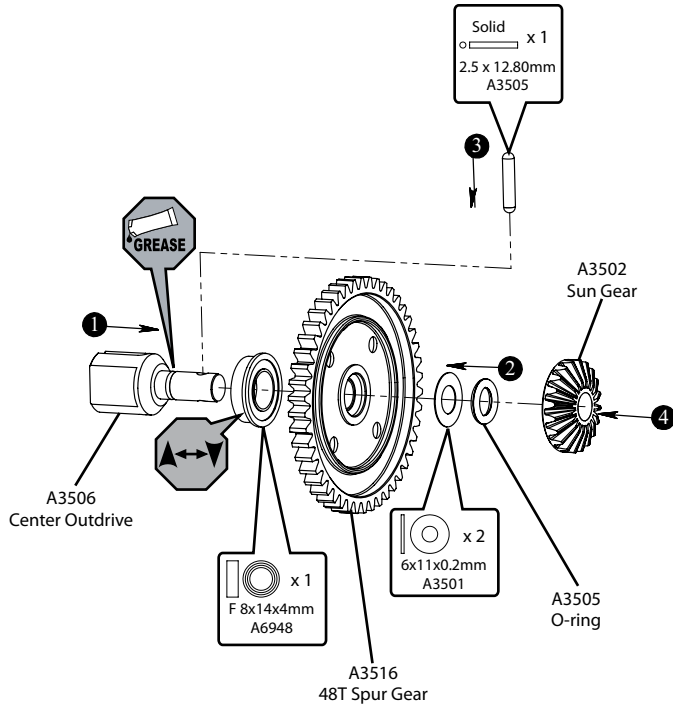

STEP C-03

Complete Diff Assembly

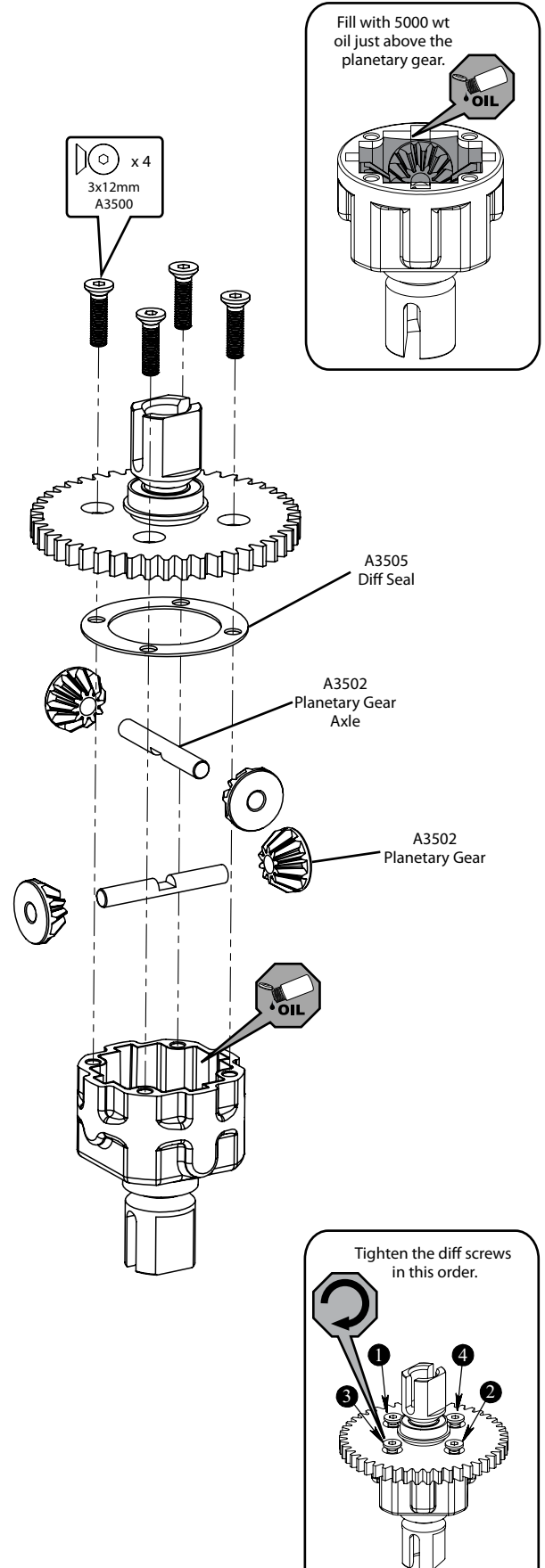

STEP C-02

Diff Case Assembly

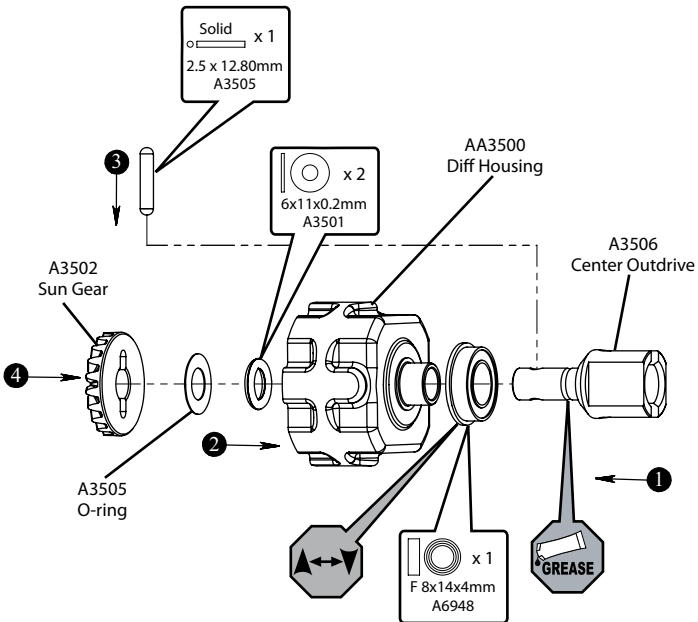

STEP C-04 Center Top Brace Assembly

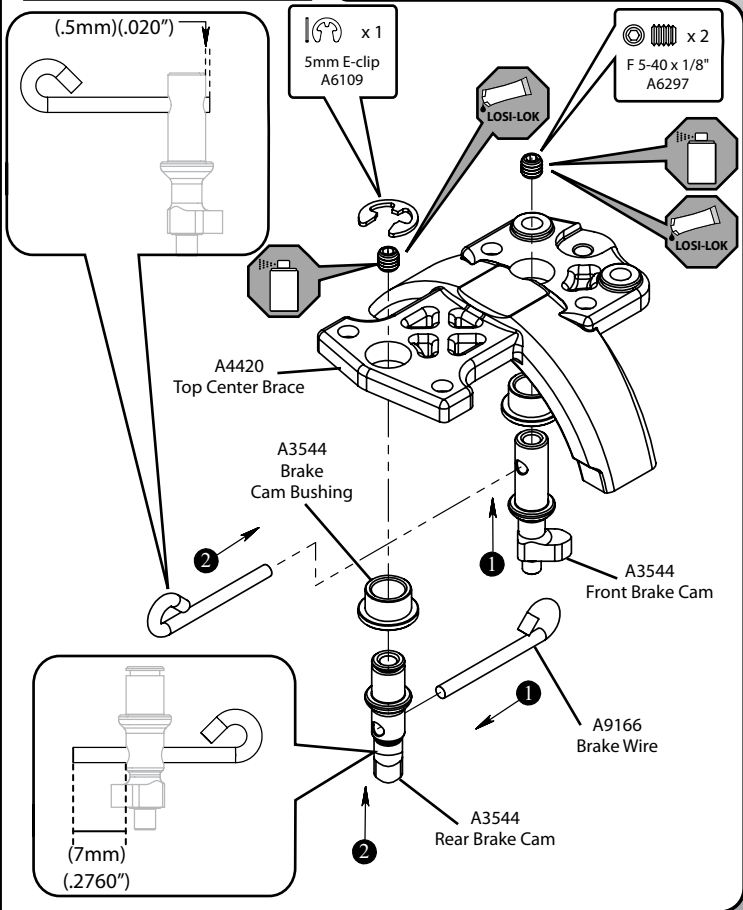

STEP C-05 Linkage Assembly

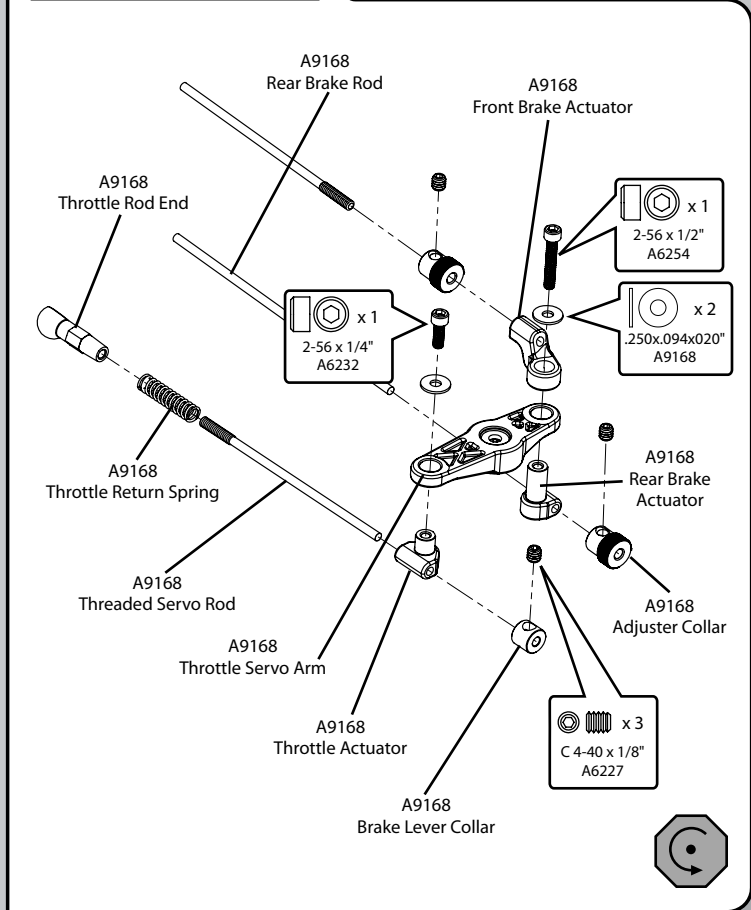

STEP C-06 Linkage Assembly

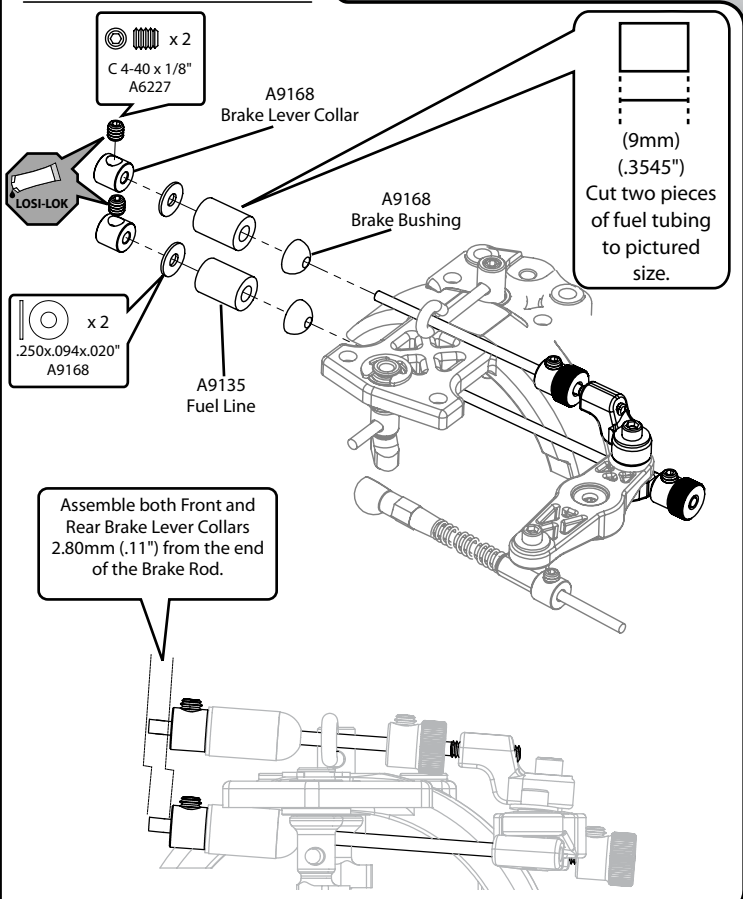

STEP C-07 Air Filter Mount & Guard

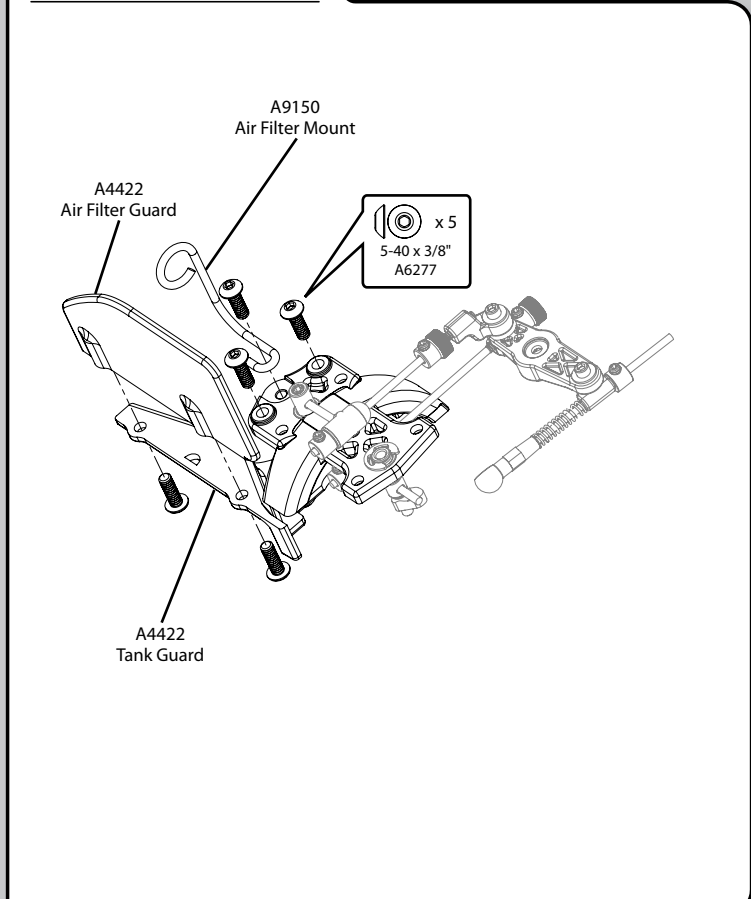

STEP C-08

Brake Caliper Assembly

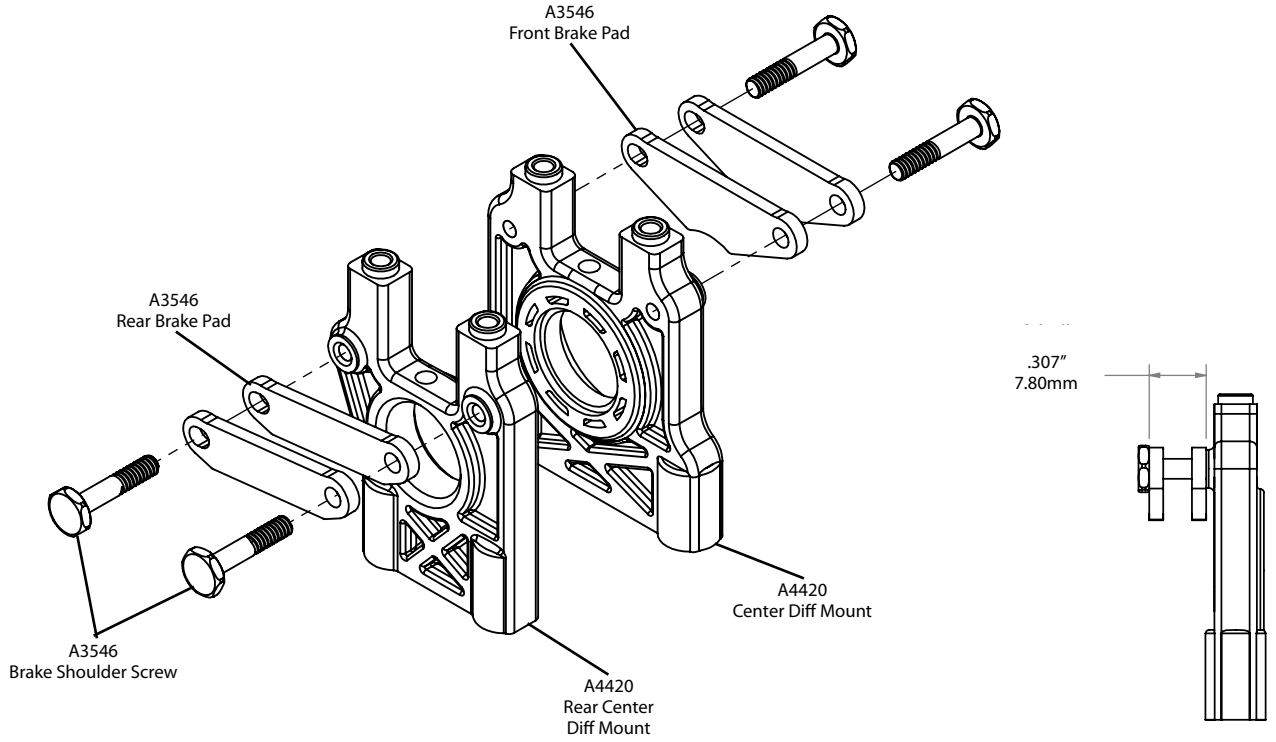

STEP C-09

Center Diff/Brake Rotor Assembly

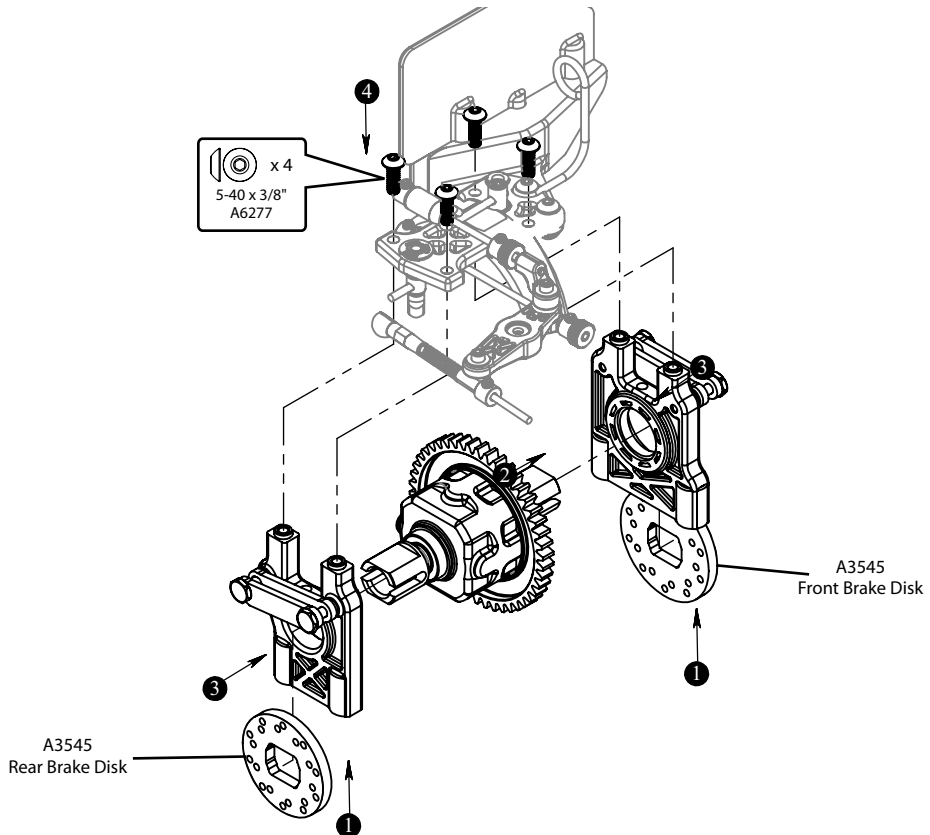

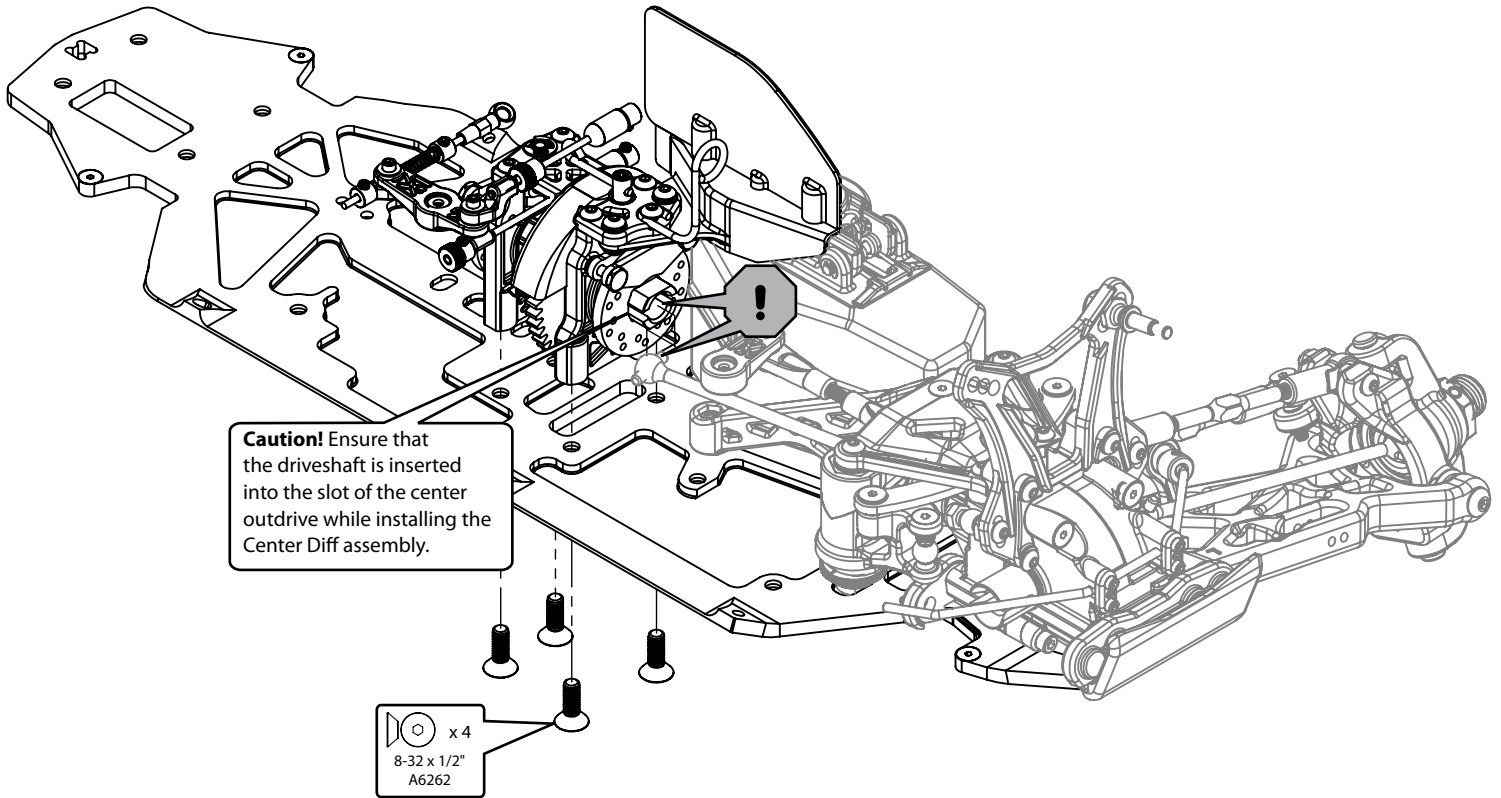
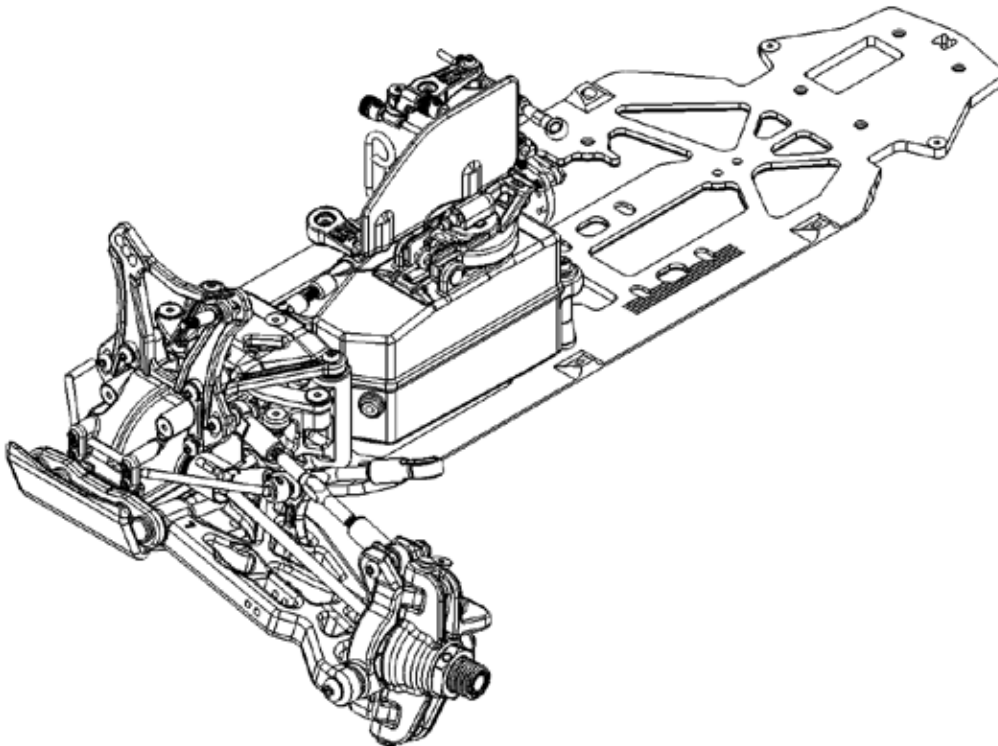
STEP C-10*Center Diff Installation***STEP C-11***Completed Center Diff Assembly*

STEP D-01

Ring Gear Assembly

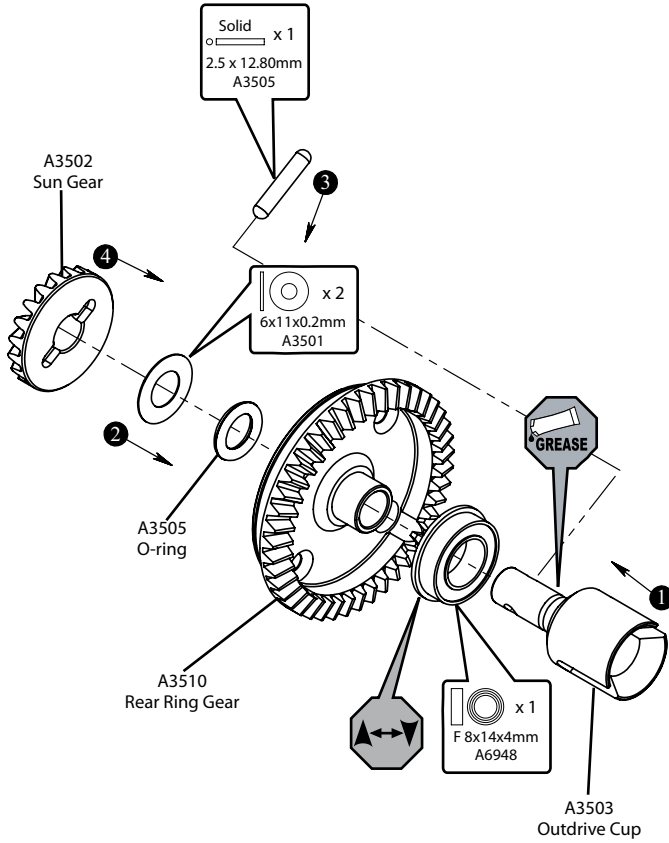

STEP D-03

Complete Diff Assembly

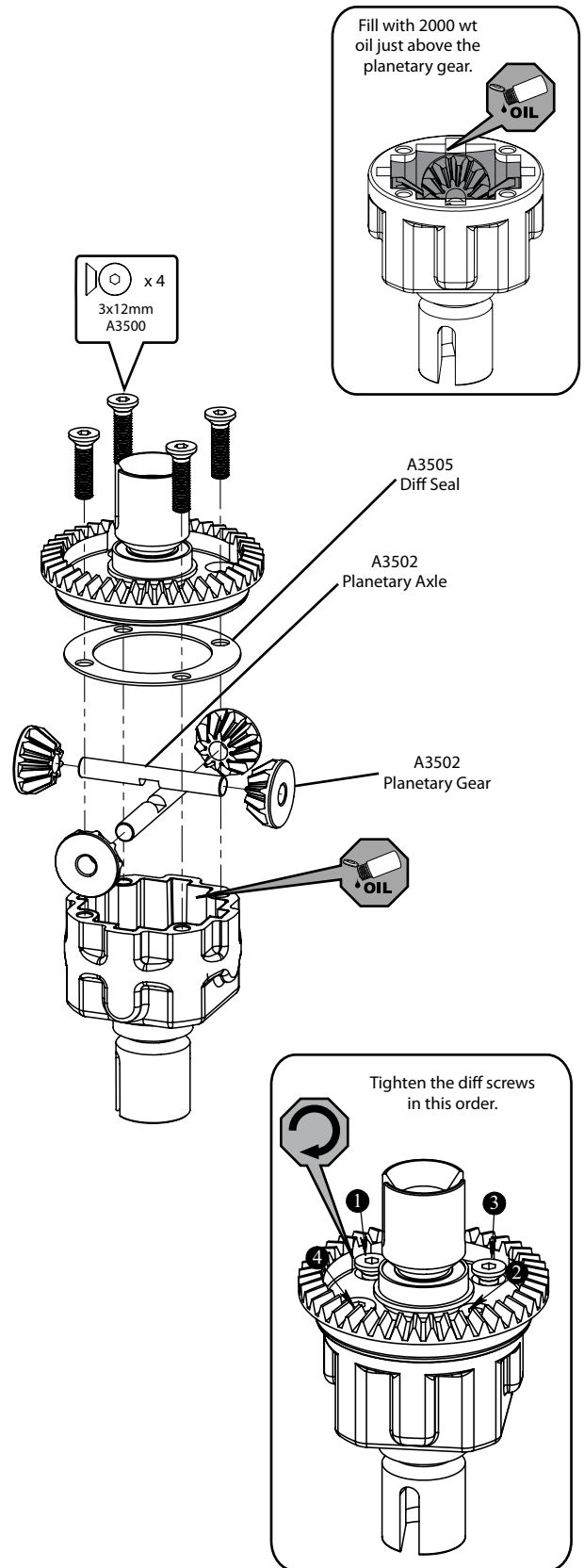

STEP D-02

Diff Case Assembly

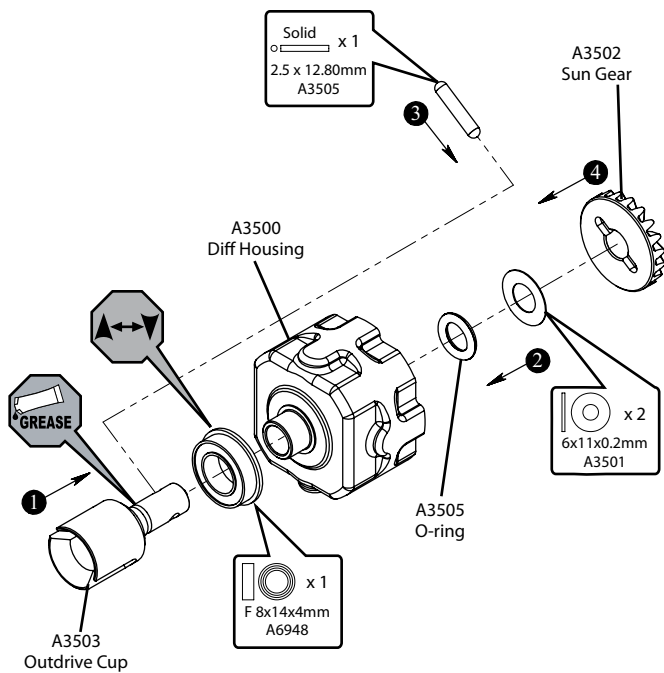

STEP D-04

Rear Diff Installation

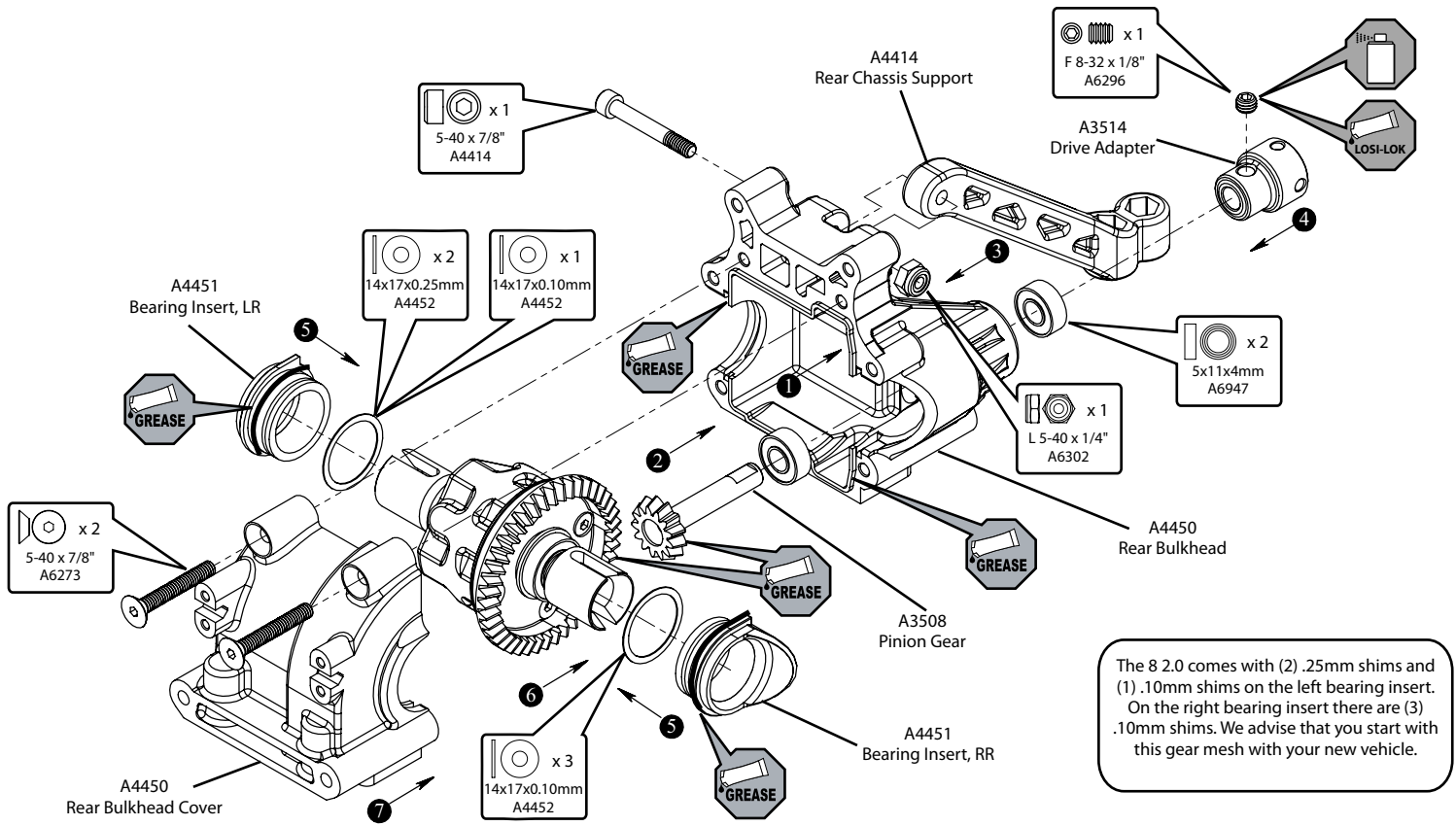

STEP D-05

Rear Hub & CV Assembly

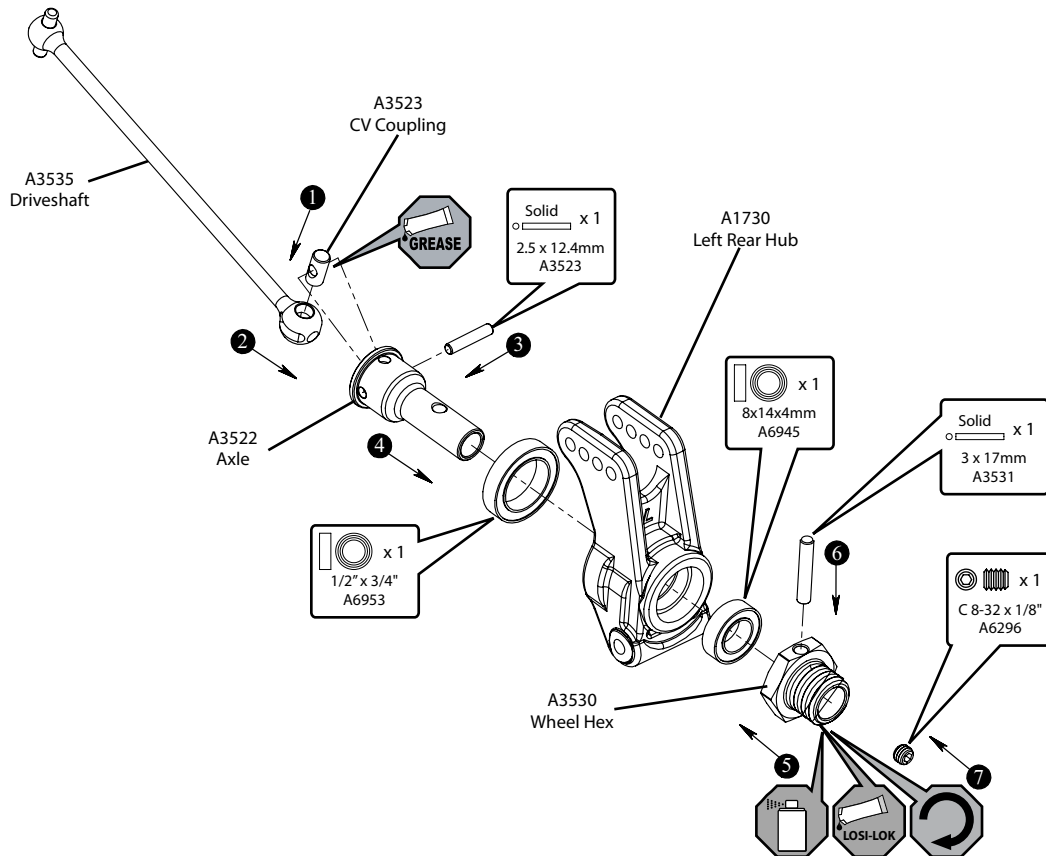

STEP D-06

Rear Suspension Arm Assembly

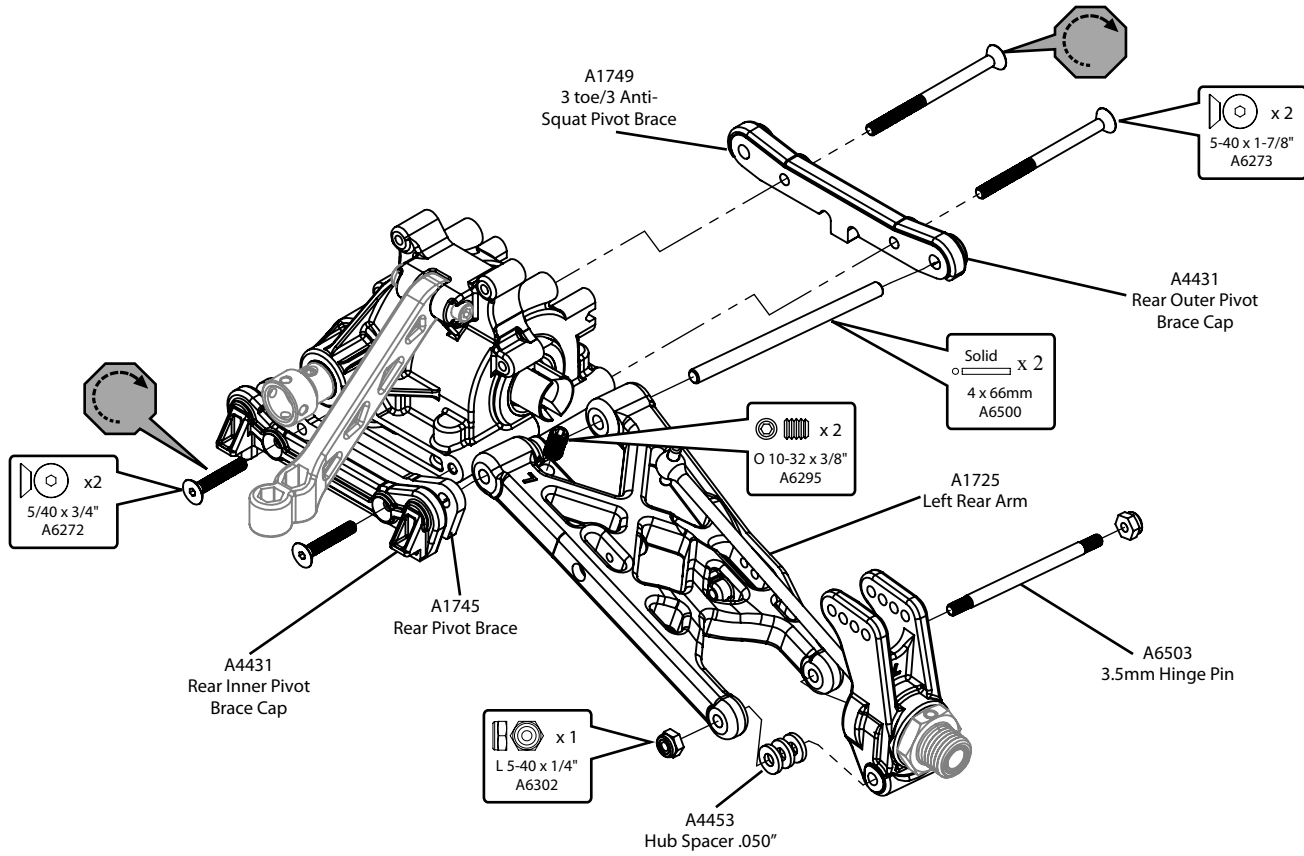

STEP D-07

Sway Bar Assembly

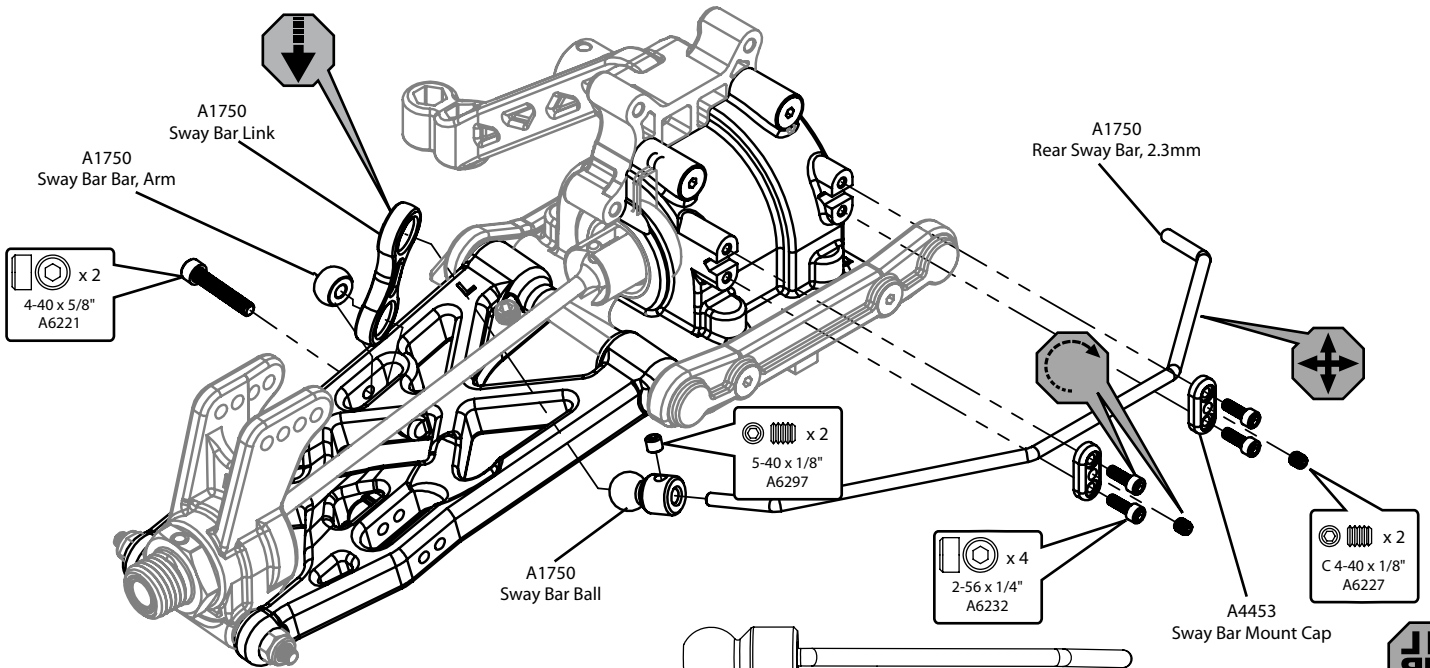

Install the Sway Bar Ball onto the Sway Bar Wire until the end of the wire is flush with the ball as pictured above.



STEP D-08

Wing Mount Assembly

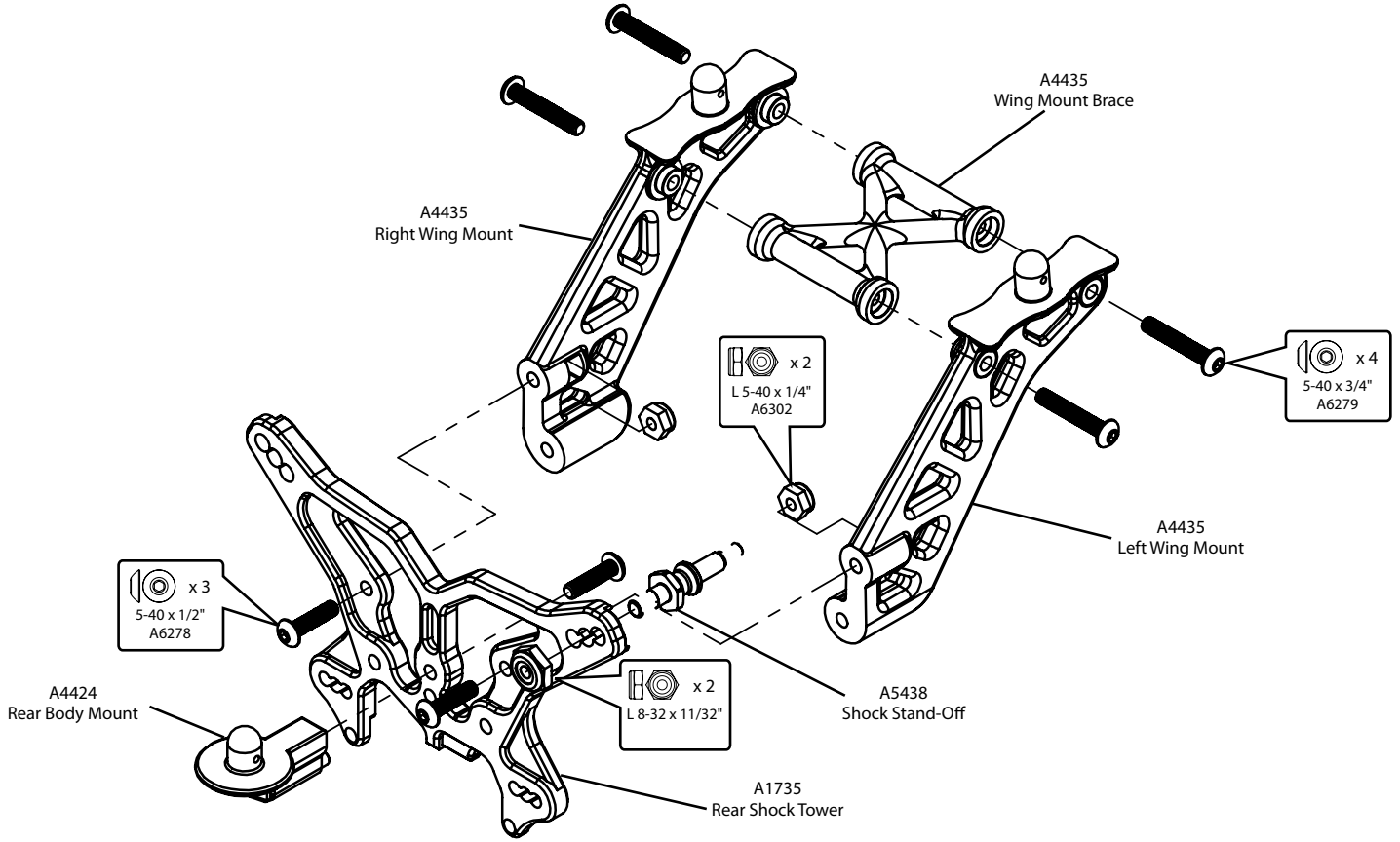

STEP D-09

Rear Shock Tower Installation

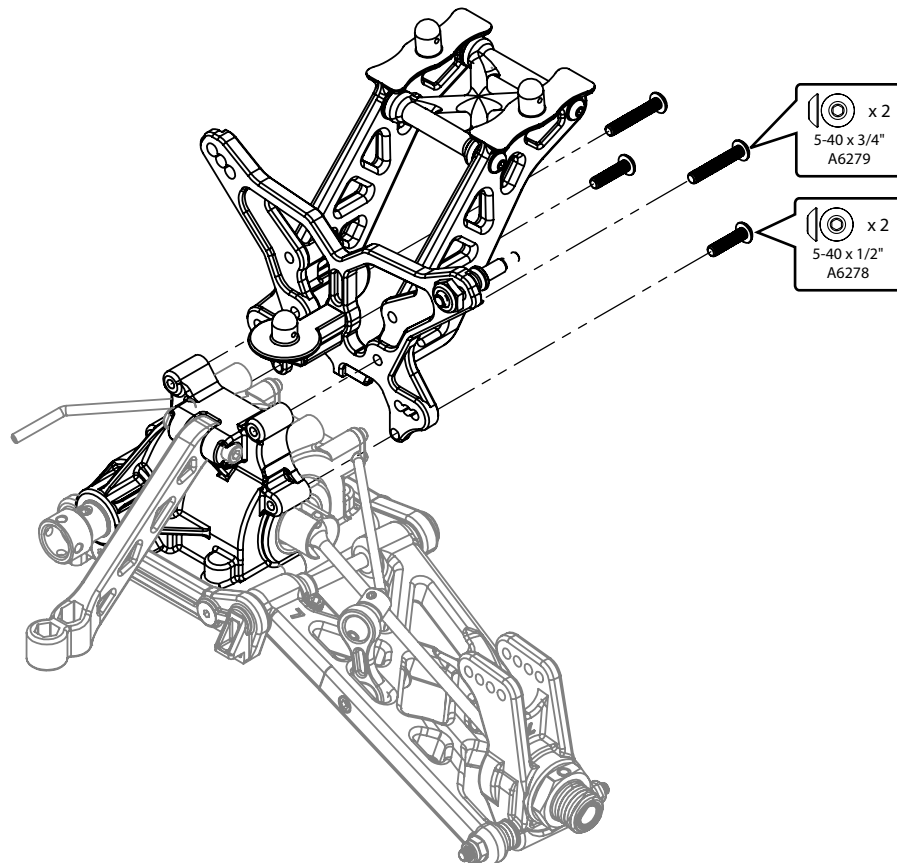

STEP D-10

Tie Rod Installation

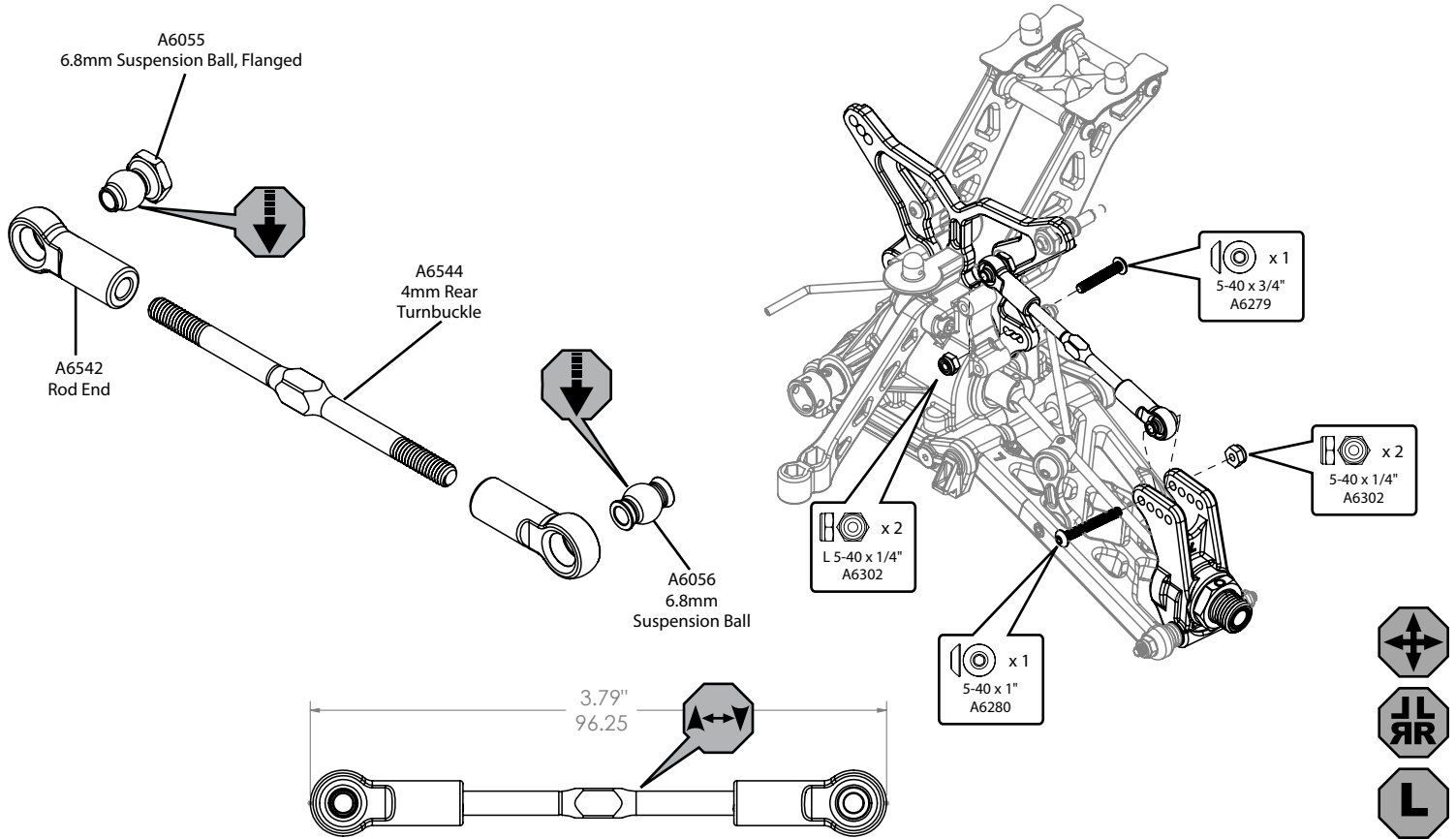

STEP D-11

Center CV Assembly

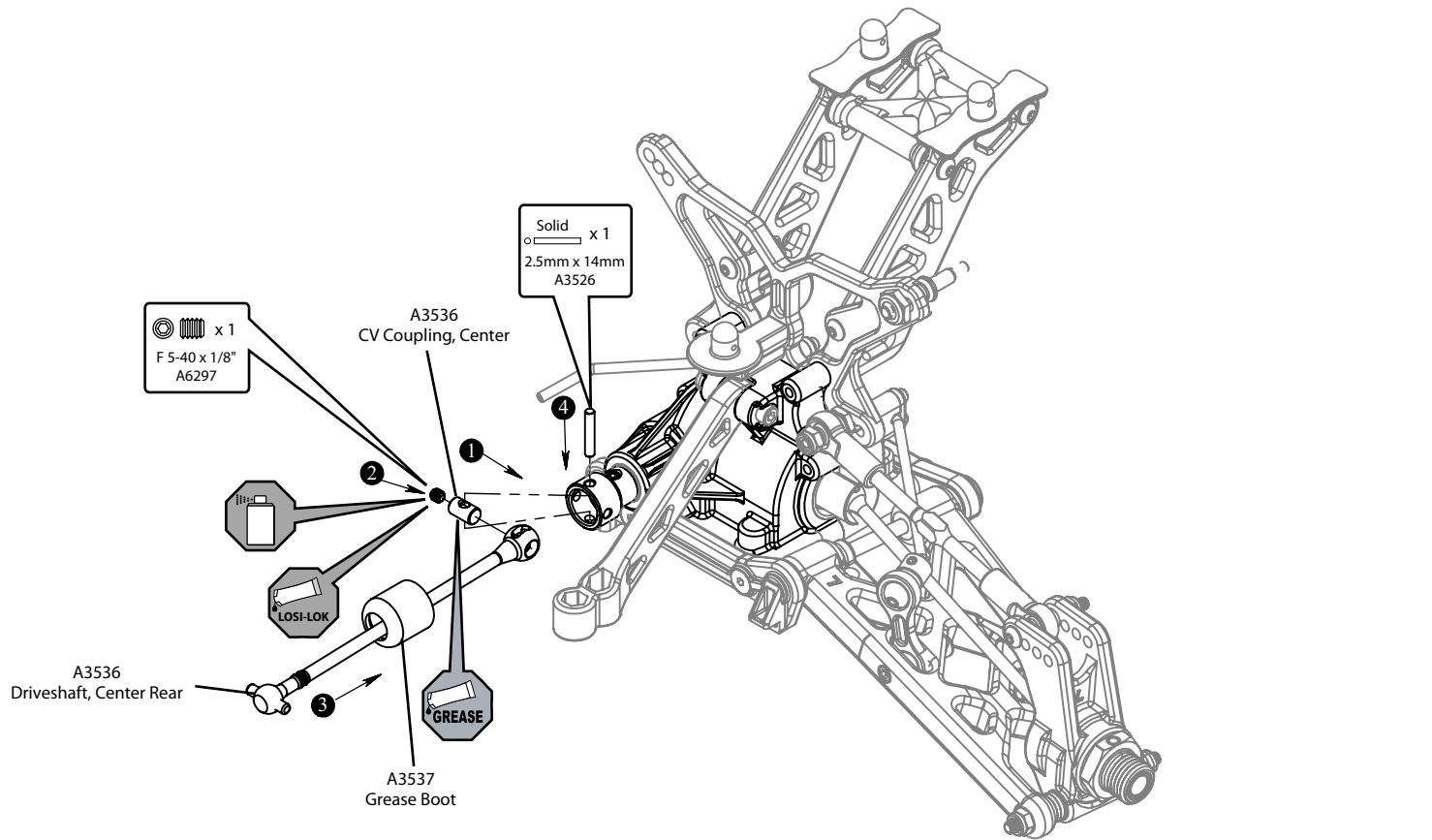

□ **STEP D-12**

Rear Clip Assembly

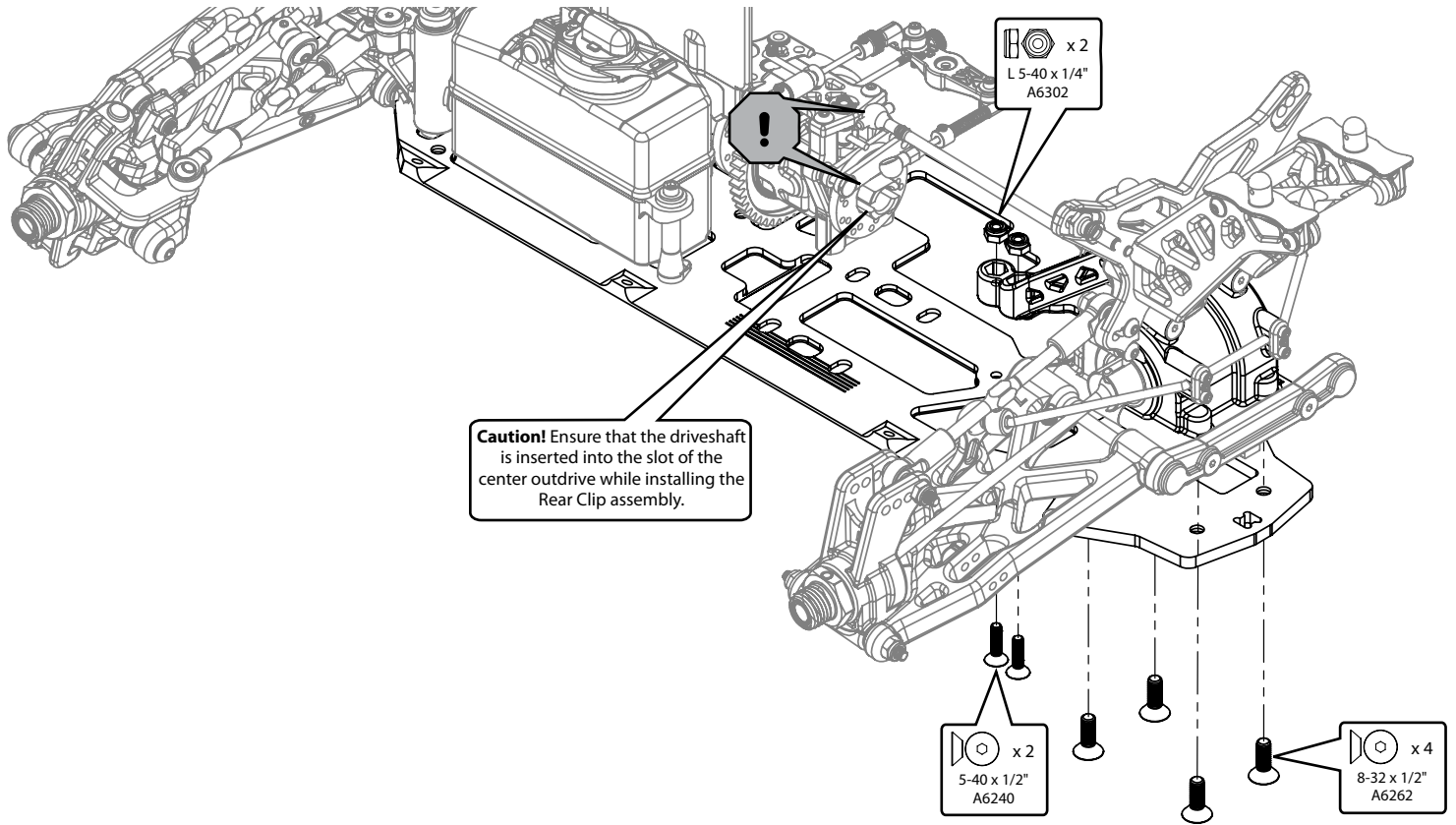

□ **STEP D-13**

Completed Rear Assembly

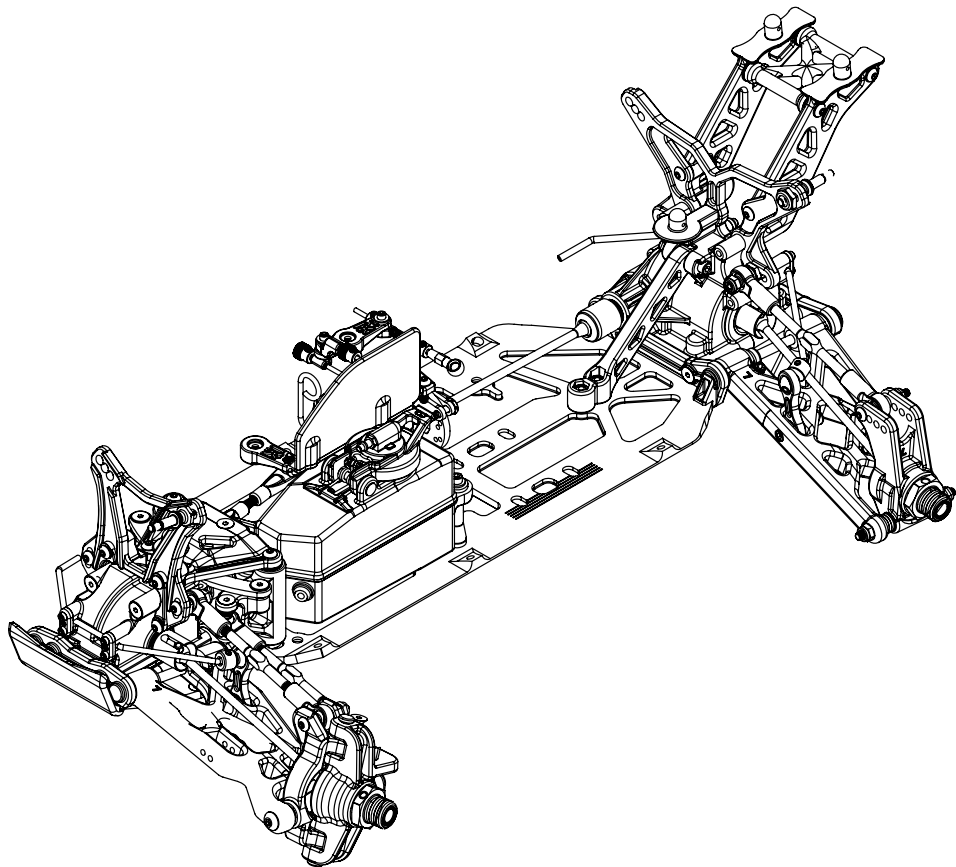

STEP E-01

Shock Assembly

- Clean the 2-56 x 1/4" Button Head Screw and apply Losi-Lok to the threads.
- Install the #54 Shock Piston on the front shock shaft and a #56 Shock Piston on the rear shock shaft using the 2-56 x 1/4" Button Screw into the Shock Shaft with a .050" Allen Wrench.
- Place a drop of Shock Oil into the bottom of the Shock Body to lubricate the Shock Seals.
- Thread the Shock Shaft into the Shock End using pliers. Used caution when threading the Shock Ends onto the Shafts. Avoid gouging or scratching the Shock Shaft while gripping the Shock Shaft with pliers by placing the edge of a towel over the shaft, then gripping the portion of the shaft covered by the towel. This method will work very well to protect the Shock Shafts from damage.
- Ensure the Shaft is fully extended when filling the shock.
- Fill the Front Shock Body with 40 wt Shock Oil and the Rear Shock Body with 25 wt until the oil is to the top of the body.
- "Work" the Shock Shaft up and down 8 times. This will release the air bubbles trapped beneath the piston. Place the filled shock, in the upright position, off to the side for a few minutes until the air bubbles escape from the oil.
- Once all the air bubbles are out of the oil, gently place the Shock Bladder onto the shock as shown. Some oil should "bleed" from the shock.
- Screw the Shock Cap onto the Body until some resistance is felt.
- Slowly push the Shock Shaft up. This will bleed excess oil from the shock.
- Tighten the cap all the way down using the shock tools included in your vehicle.
- Move the Shock Shaft up and down. The shaft should be easy to push up into the body of the shock. If increased pressure is felt towards the top, there is too much oil in the shock. Loosen the Shock Cap and "bleed" the shock as done previously.
- Make sure each pair (front/rear) Shocks have the same rebound and compression. This is checked by holding one shock in each hand horizontally and pushing them together by the Shock End. Watch carefully to ensure that both compress evenly. Now release both shocks and again watch carefully as they should rebound the same.
- Install the Shock Adjustment Nut O-ring into the Shock Adjustment Nut before installing the Nut onto the Shock Body.

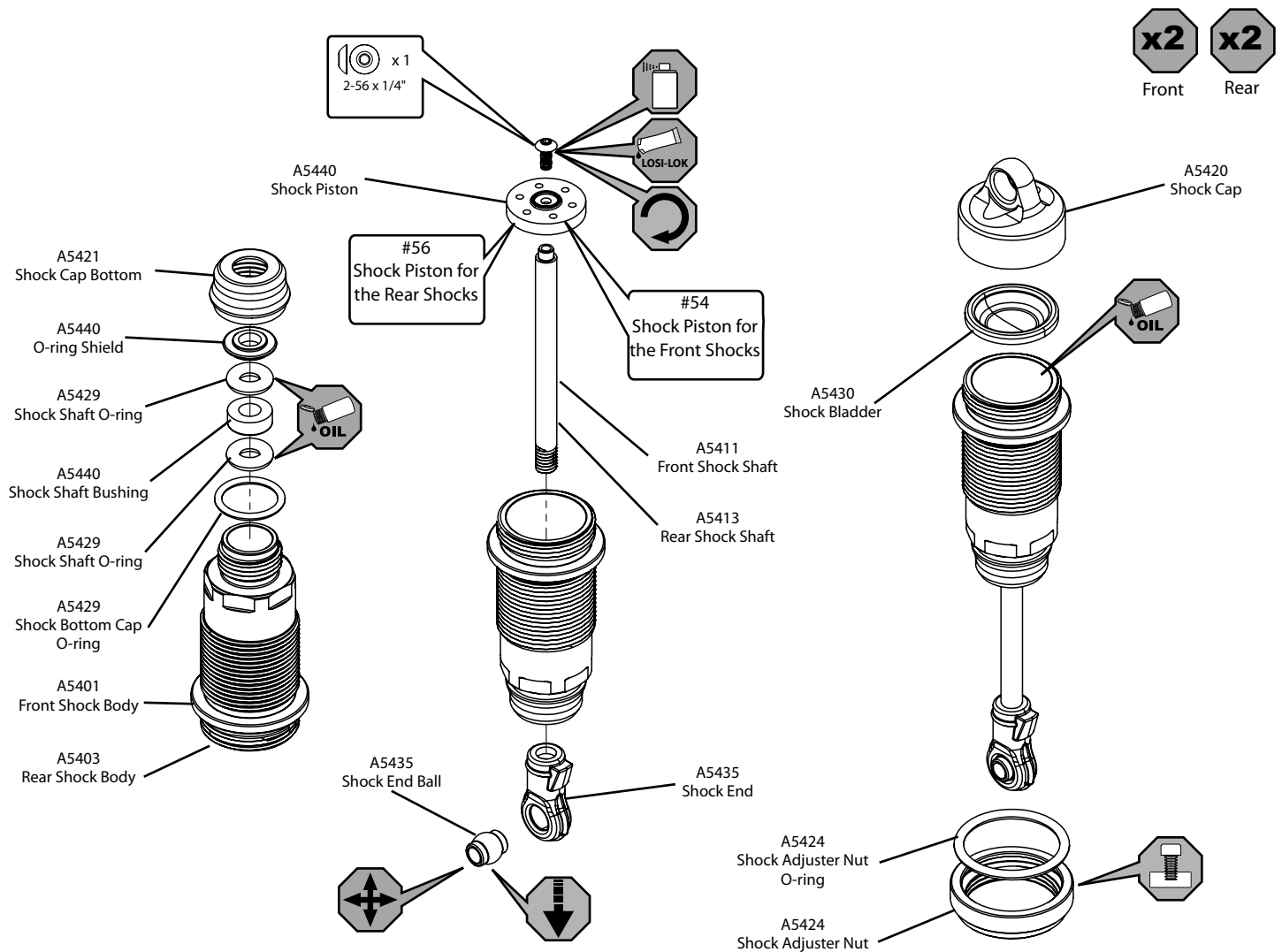

□ **STEP E-02**

Shock Boot & Spring Assembly

x2
Front

x2
Rear

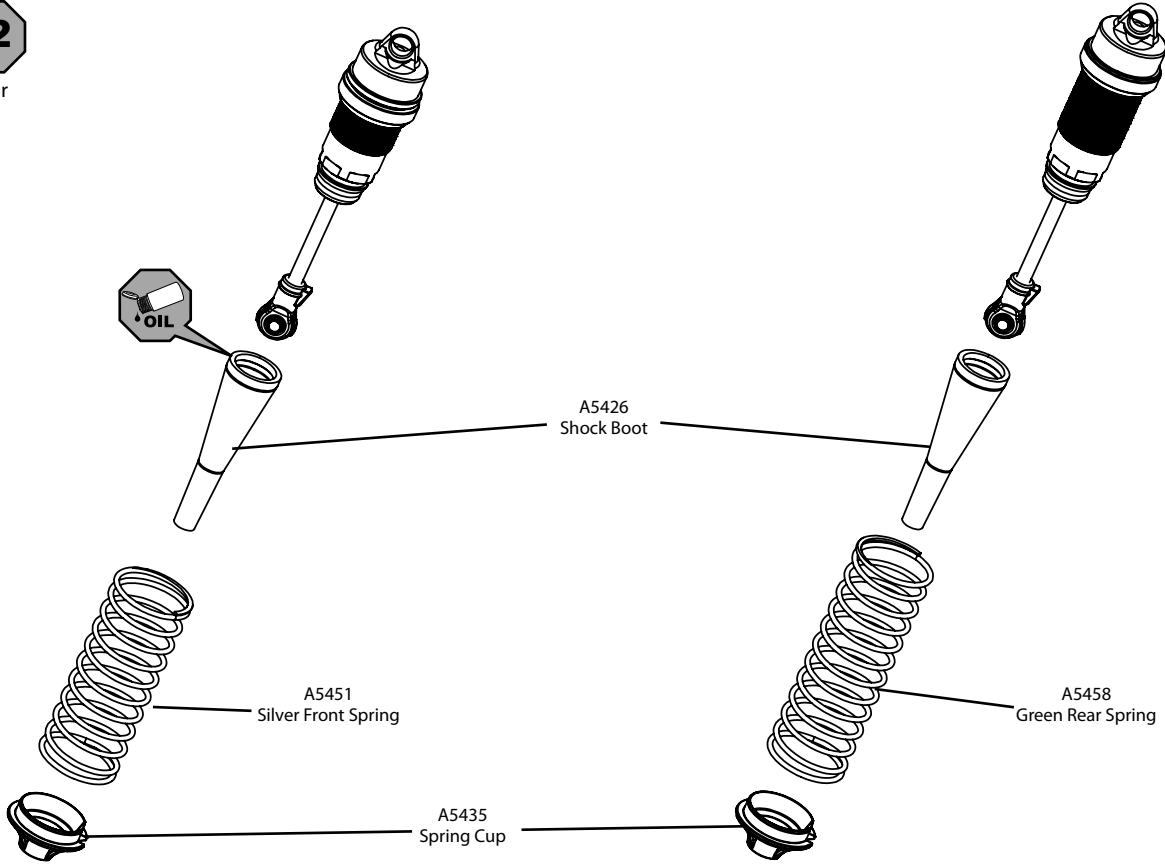

□ **STEP E-03**

Front Shock Installation

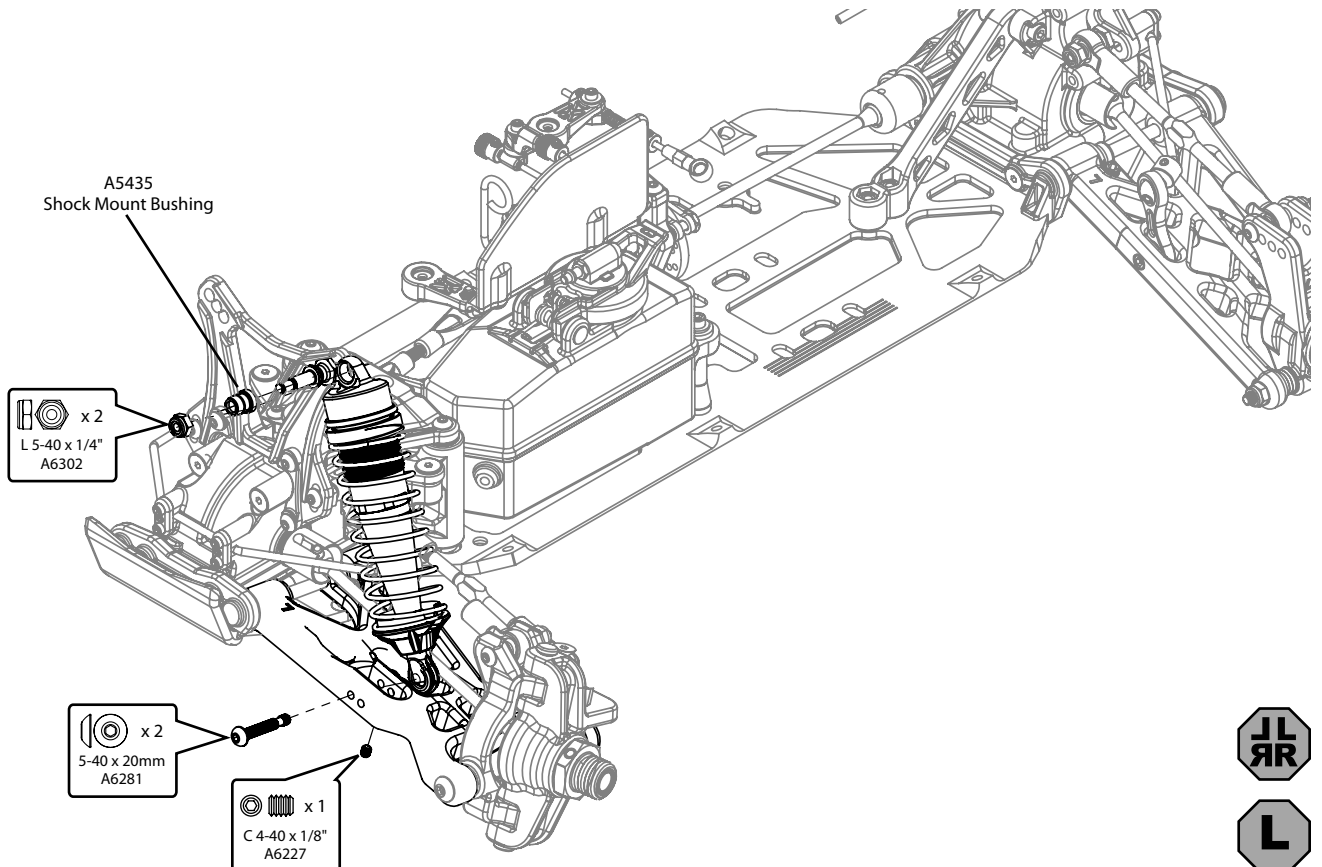

□ **STEP E-04**

Rear Shock Installation

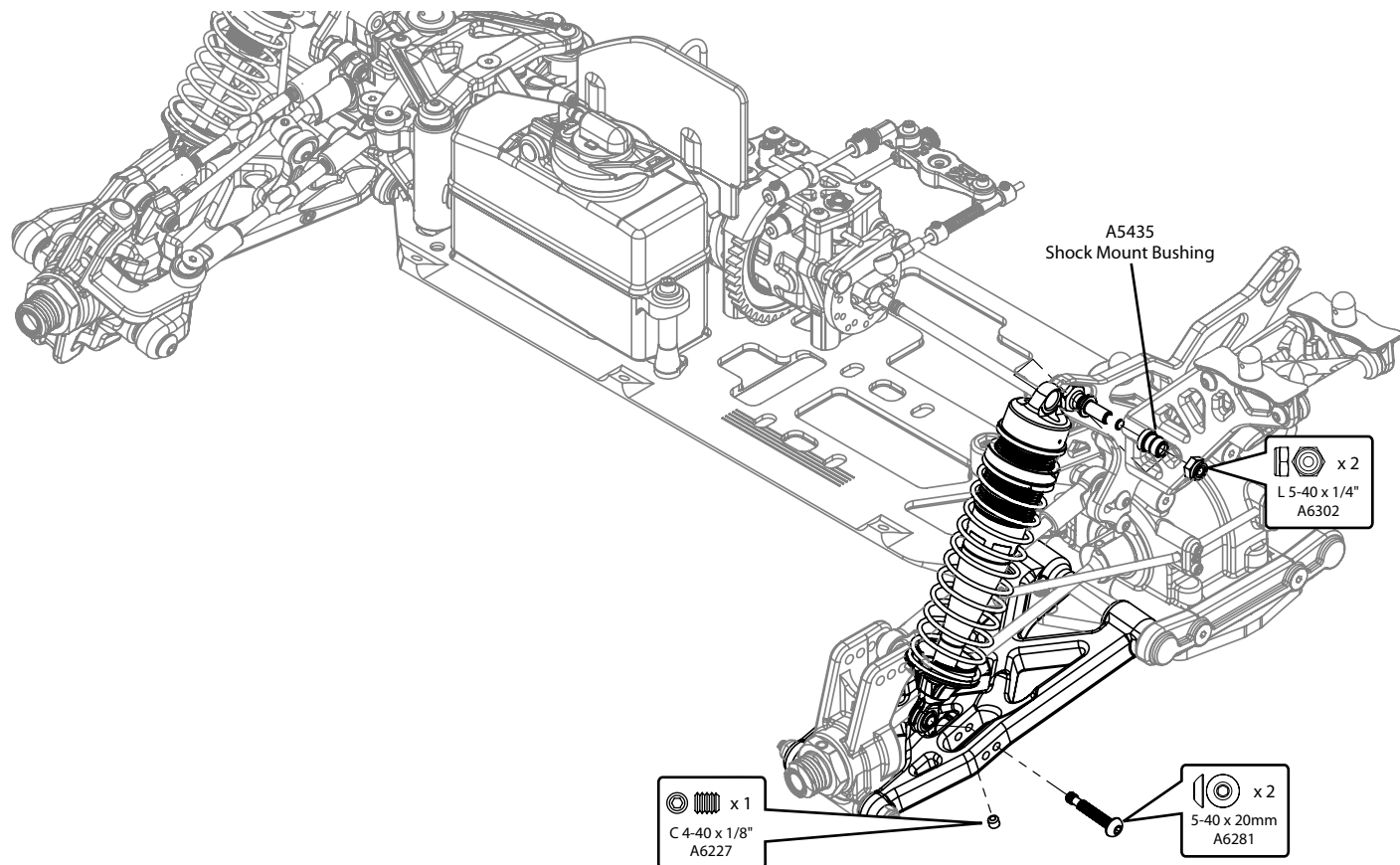

□ **STEP E-05**

Completed Shock Assembly

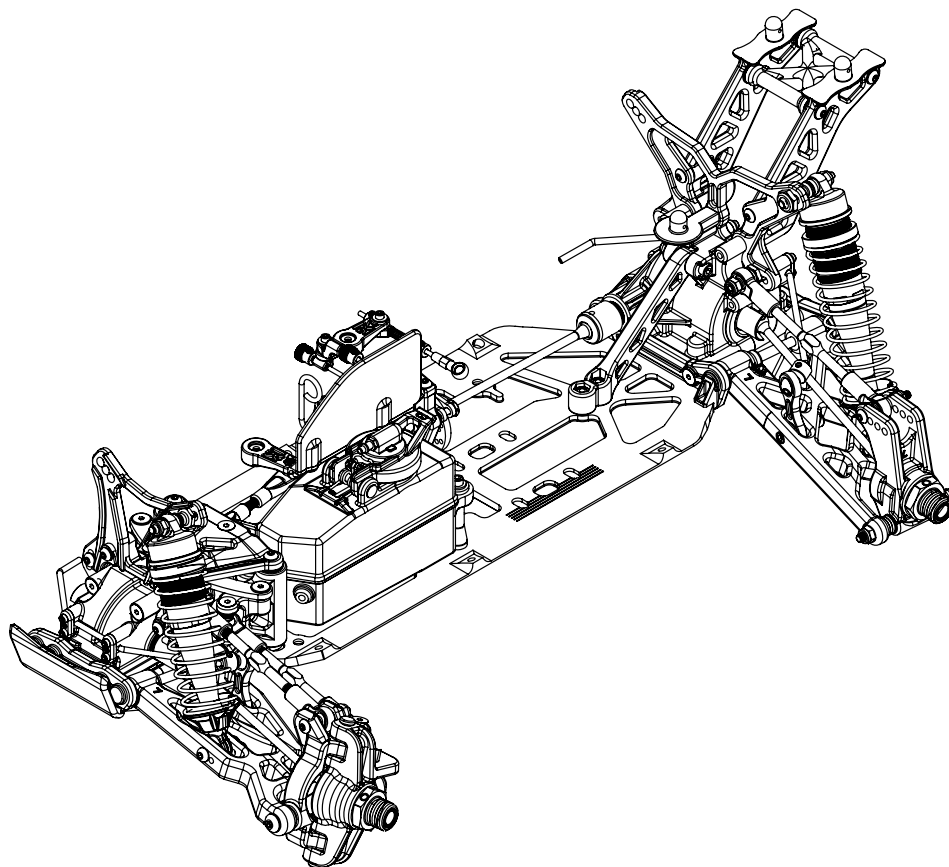

□ **STEP F-01**

Chassis Guard Installation

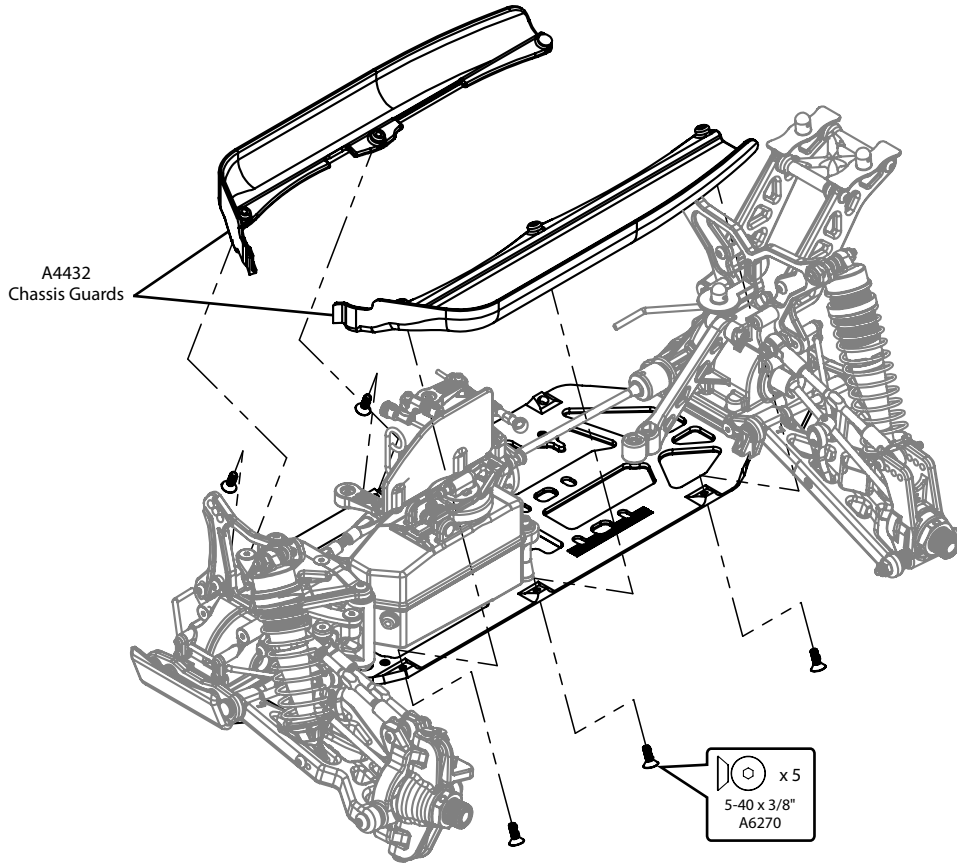

□ **STEP F-02**

Switch Installation

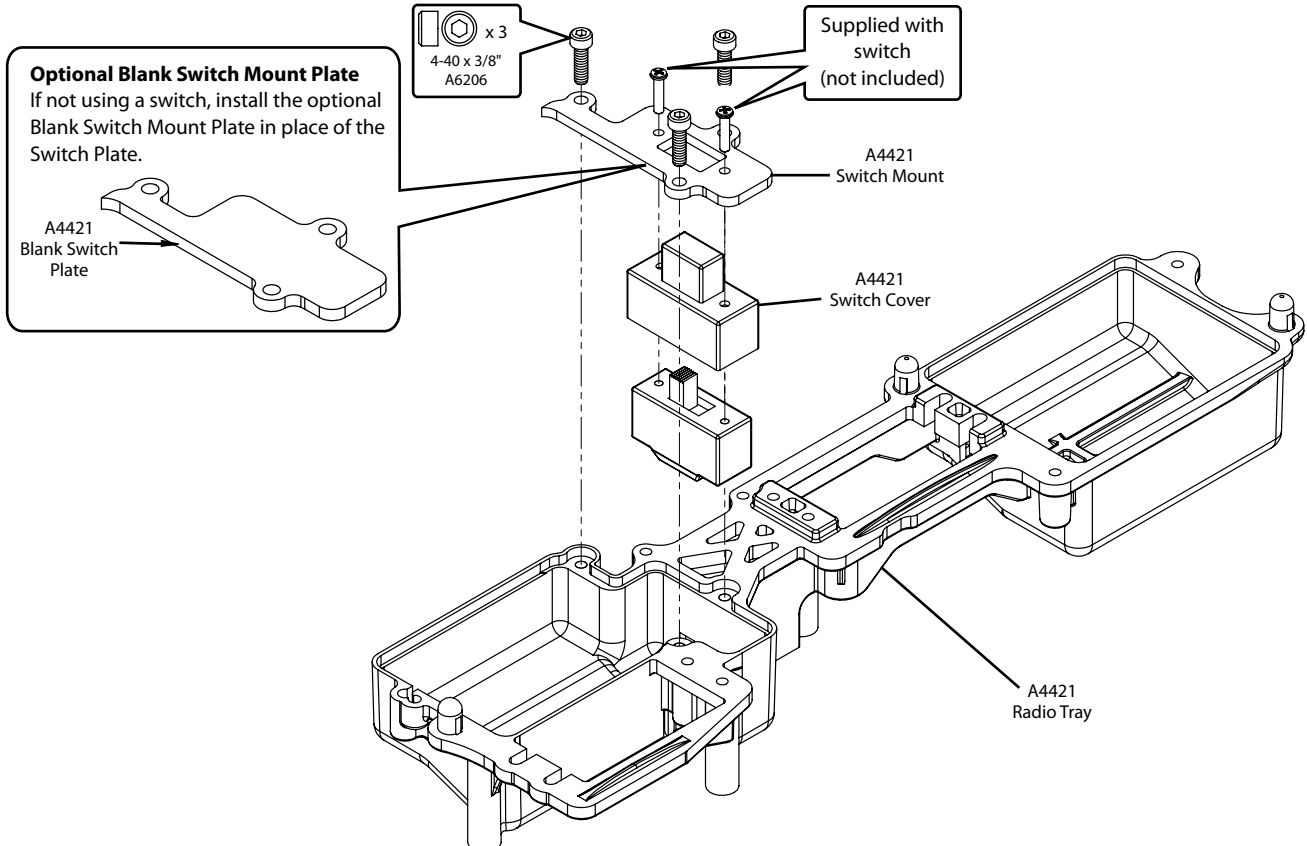

Optional Blank Switch Mount Plate
If not using a switch, install the optional Blank Switch Mount Plate in place of the Switch Plate.

A4421
Blank Switch
Plate

Supplied with
switch
(not included)

A4421
Switch Mount

A4421
Switch Cover

A4421
Radio Tray

STEP F-03

Servo Chart/Wiring Diagram

Servo Manufacturer, Make/Model		Servo Spacer	Servo Horn
JR	All (DZ9100T/S Needs Spacer)	No	23T
Airtronics Sanwa	94357Z, 94358Z, 94649Z, 94360Z, 94452Z, 94758Z, 94737Z, 94738Z	Yes	23T
	94102Z, 94112Z	Yes	
Hitec	All	No	24T
Futaba	All (S9102 DOES NOT FIT)	No	25T
KO ProPO	PDS-2123, 2344, 2363, 2365, 2366	No	23T
		No	

Table2: Servo assembly and installation

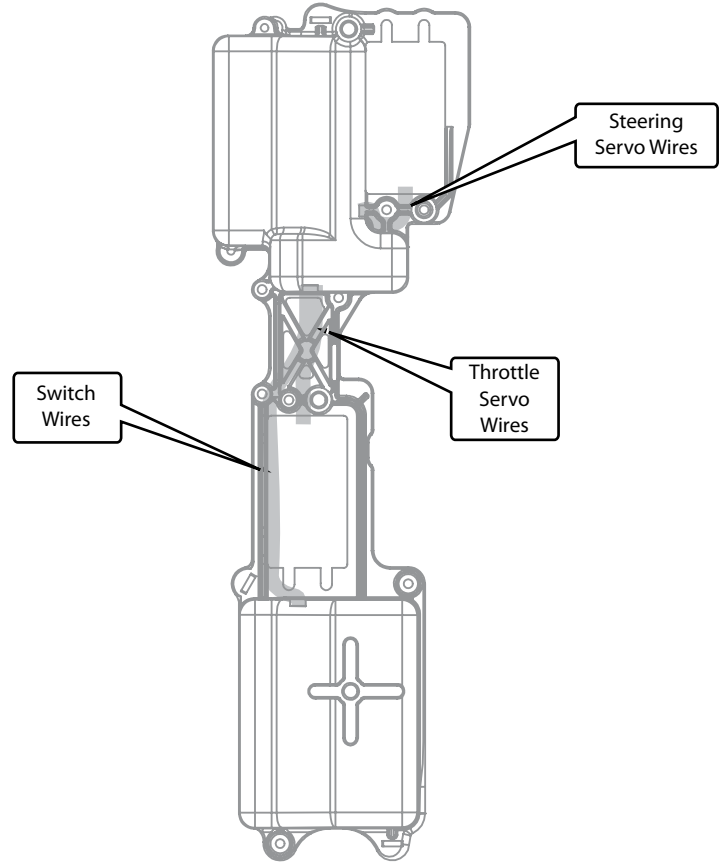

Airtronics® is a registered mark of Sanwa Electronic Instrument Co., Ltd., Osaka, Japan.
Futaba is a registered trademark of Futaba Denshi Kogyo Kabushiki Kaisha Corporation of Japan
KO PROPO® is a registered trademark of Kondo Kagaku Co., Ltd., Tokyo, Japan.

STEP F-04

Throttle Servo Installation

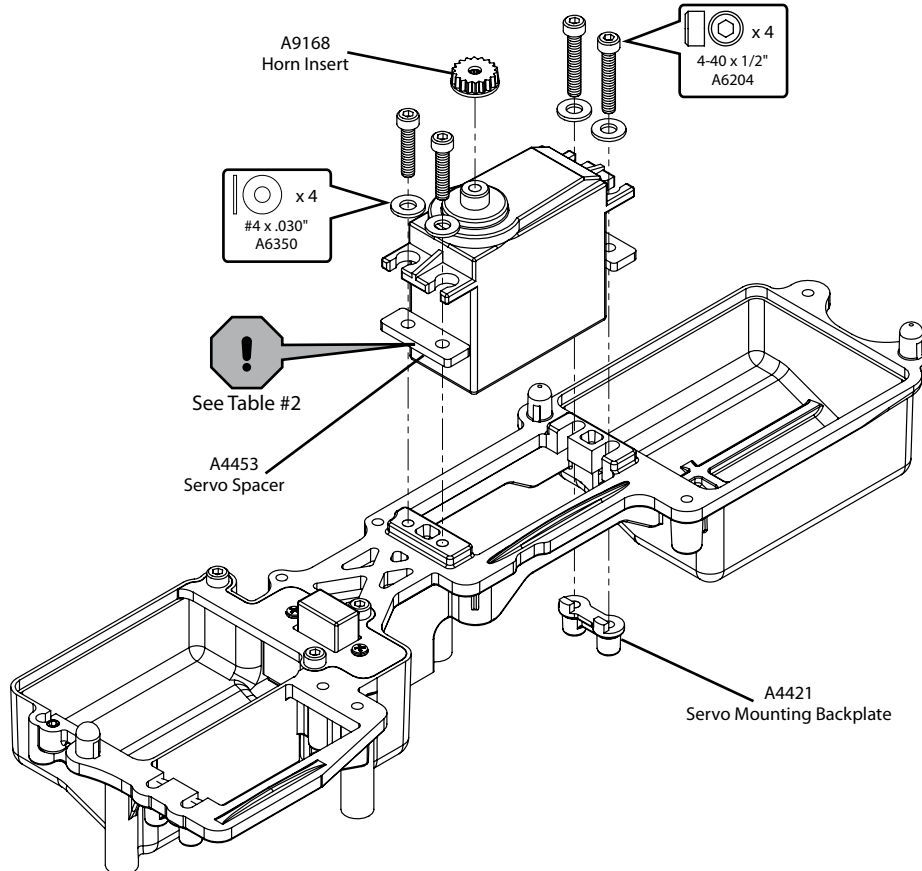

STEP F-05

Steering Servo Installation

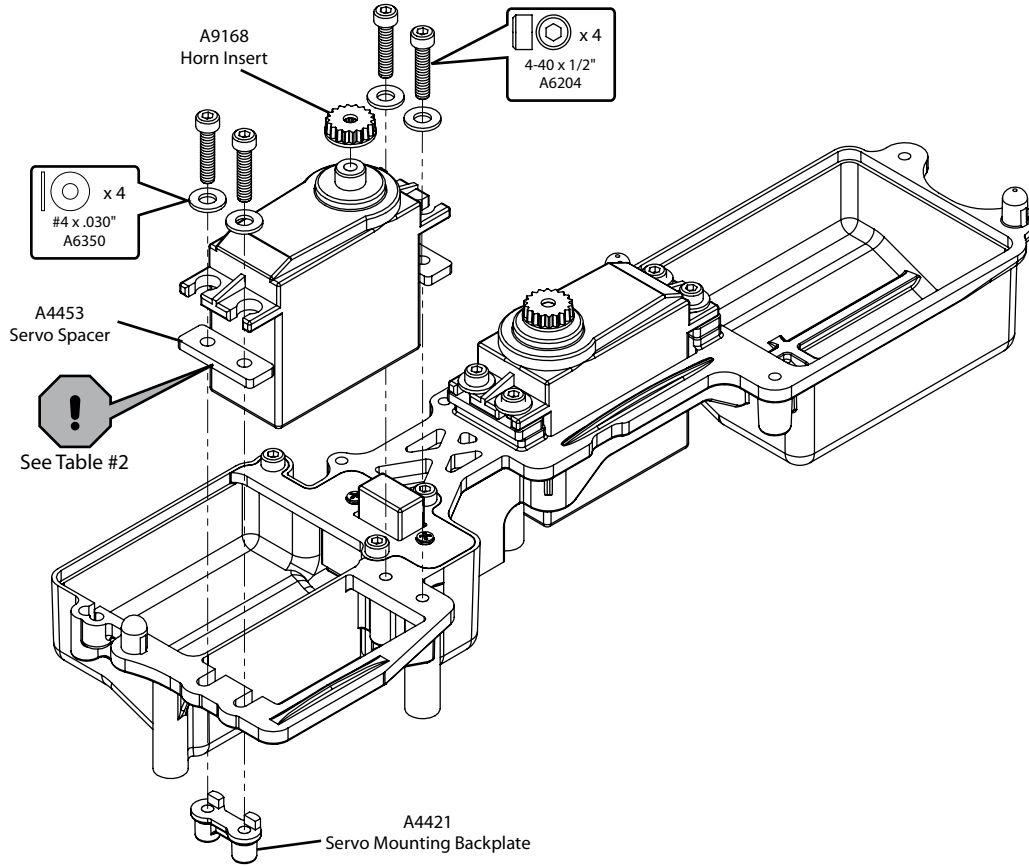

STEP F-06

Receiver/Antenna Tube Assembly

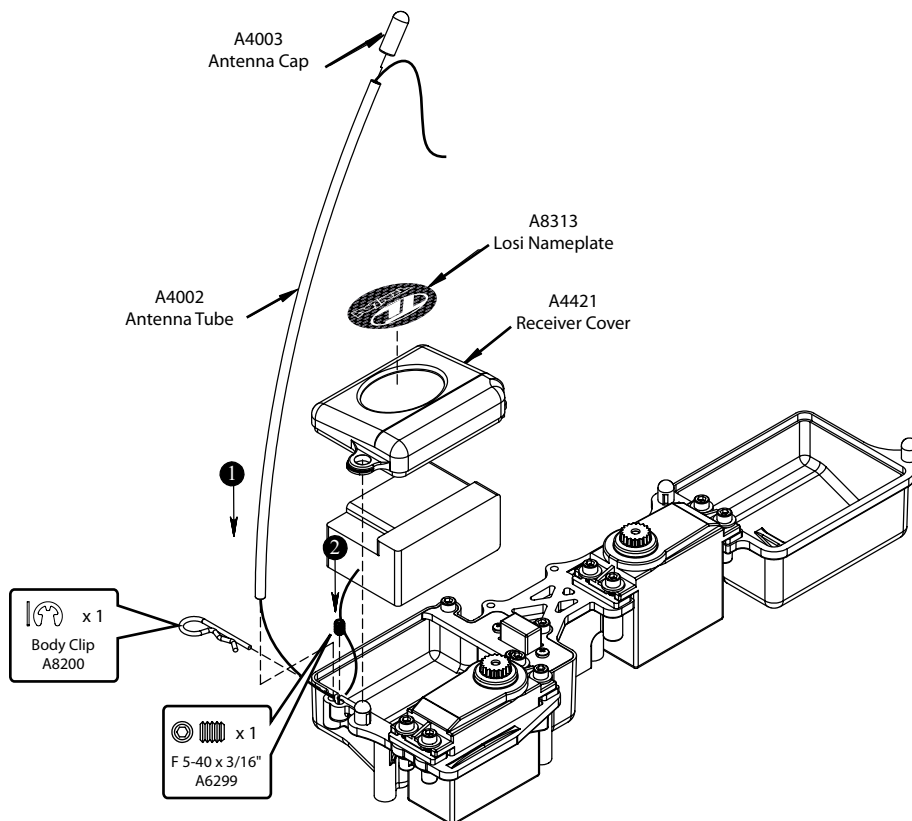

□ **STEP F-07**

Receiver Battery Door

Optional Battery Covers

High Profile Cover should be used with Hump pack type receiver packs. Low Profile Cover should be used with LiPo type receiver packs.

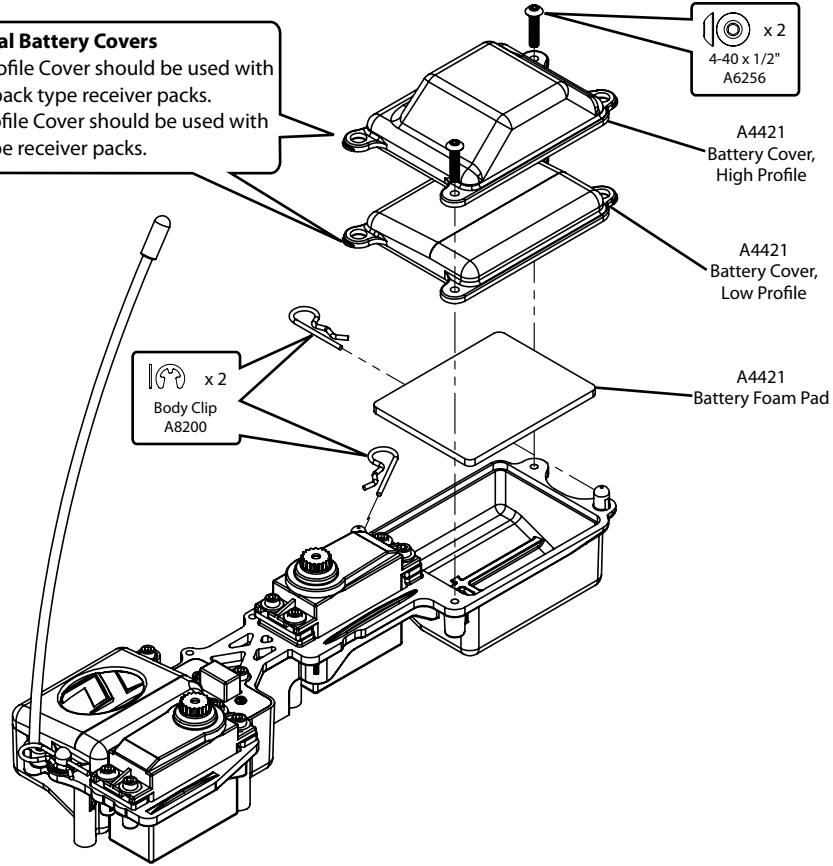

□ **STEP F-08**

Radio Tray Installation

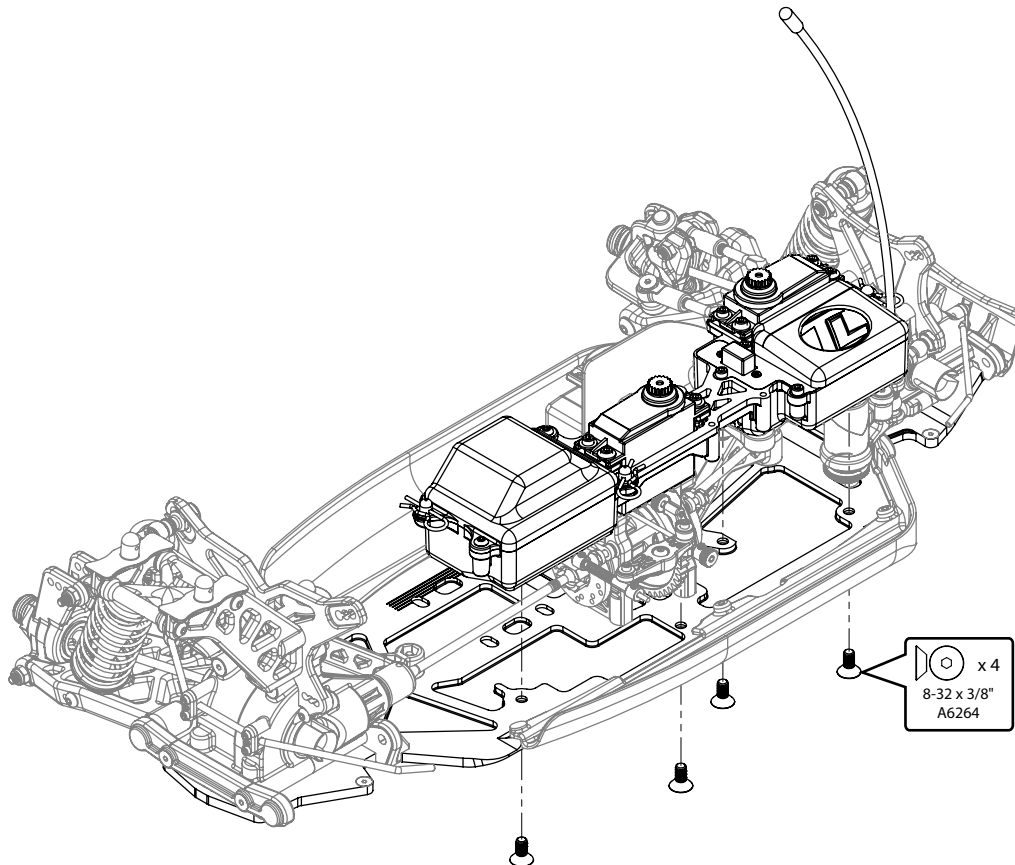

□ **STEP F-09**

Servo Horn Installation

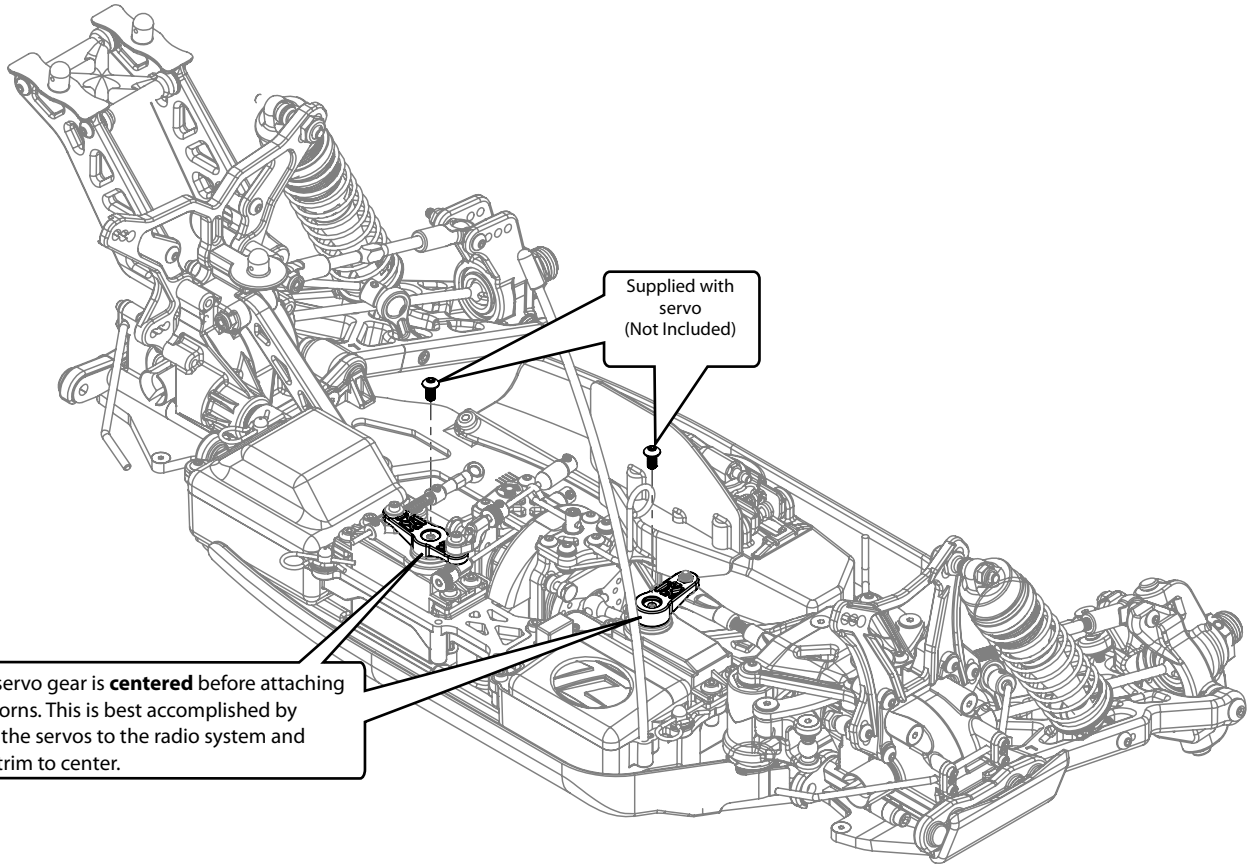

□ **STEP F-10**

Completed Radio Tray Installation

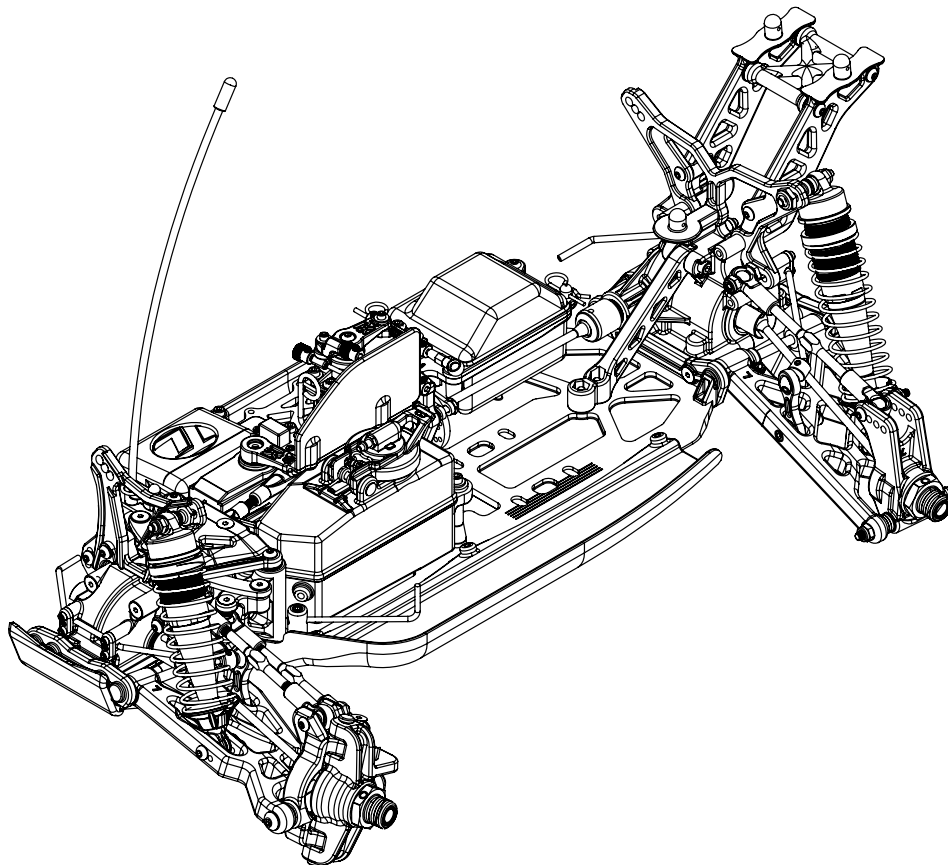

□ **STEP G-01**

Clutch Assembly

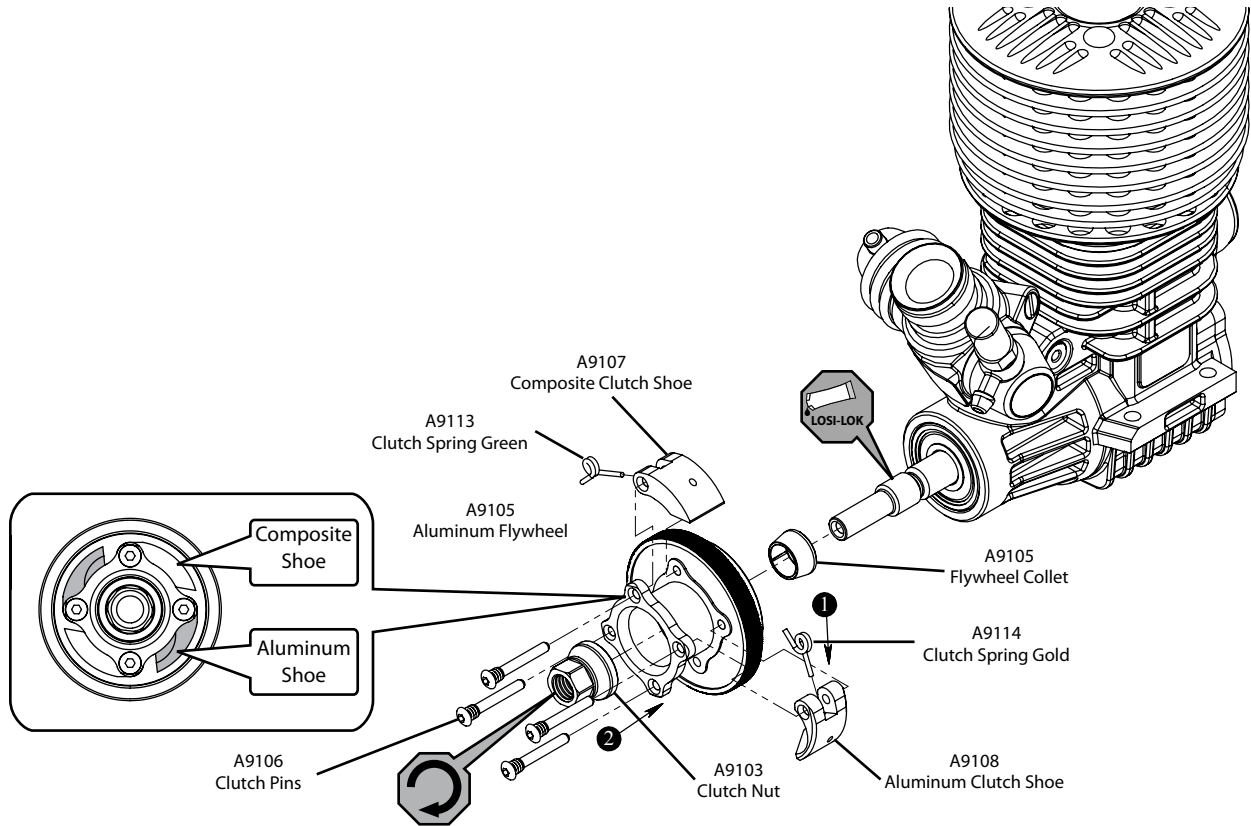

□ **STEP G-02**

Clutch Bell Assembly

Use the appropriate number of shims to achieve proper clutchbell end play. Generally .25mm to .50mm is optimum.

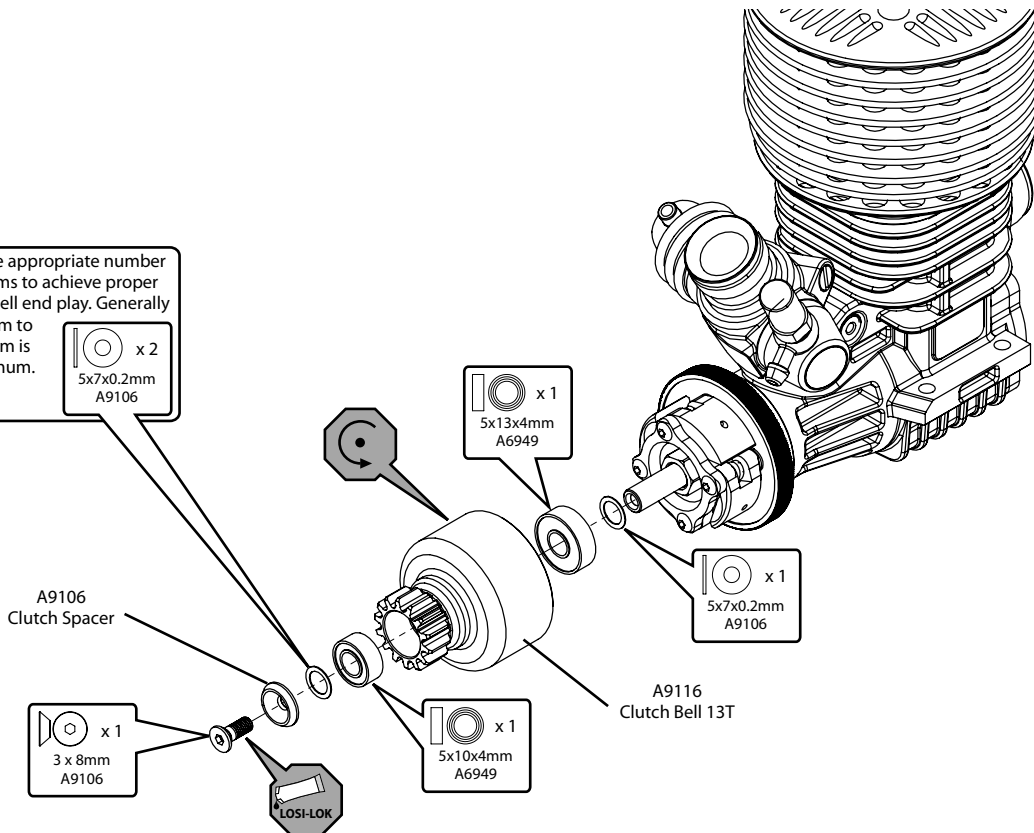

STEP G-03

Engine Mount Assembly

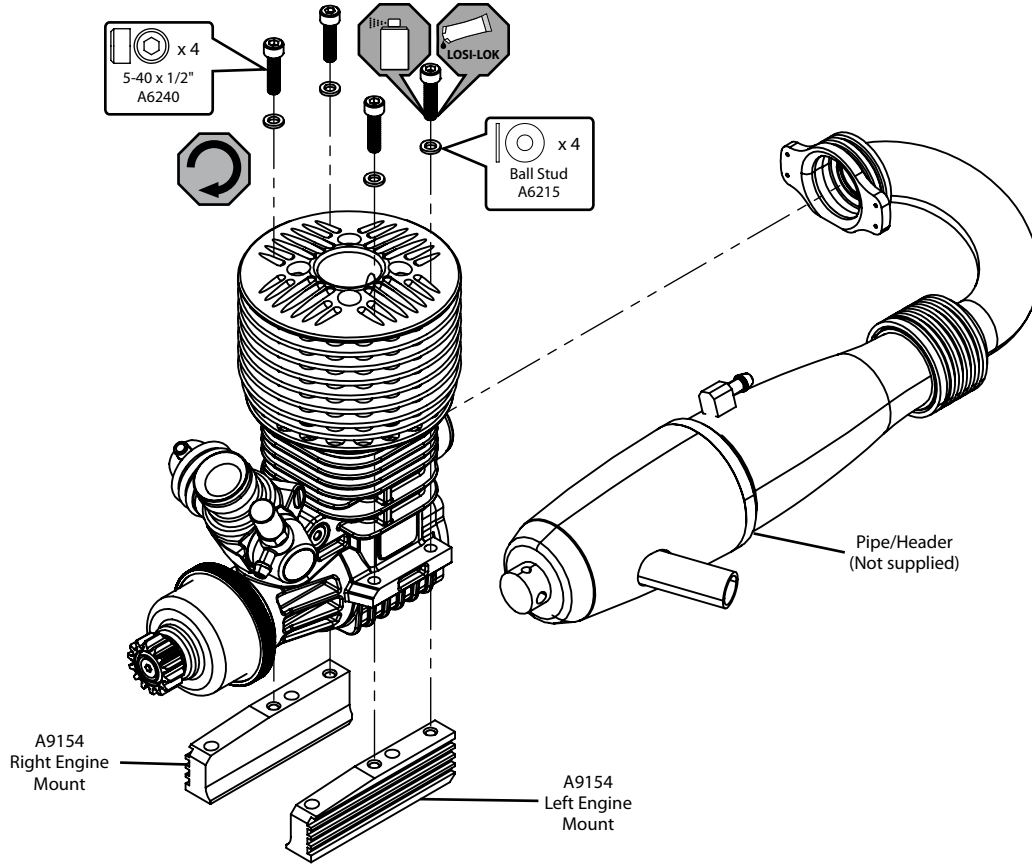

STEP G-04

Air Filter Assembly

Tech Tip

With a clean rag or paper towel take the air filter and squeeze it between the rag and squeeze it between the rag to remove any excess air filter oil. The goal is to remove all the oil blotches from the filter to improve engine performance.

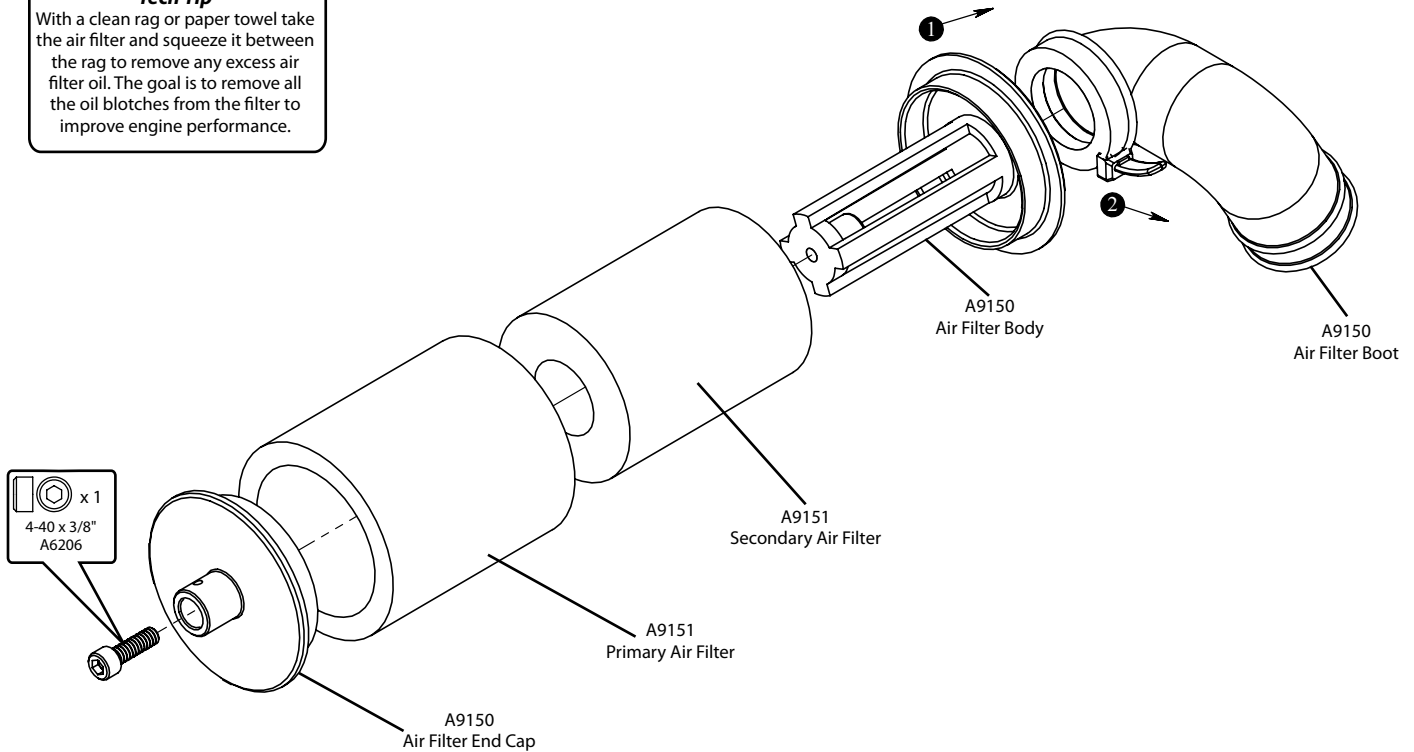

□ **STEP G-05**

Air Filter Installation

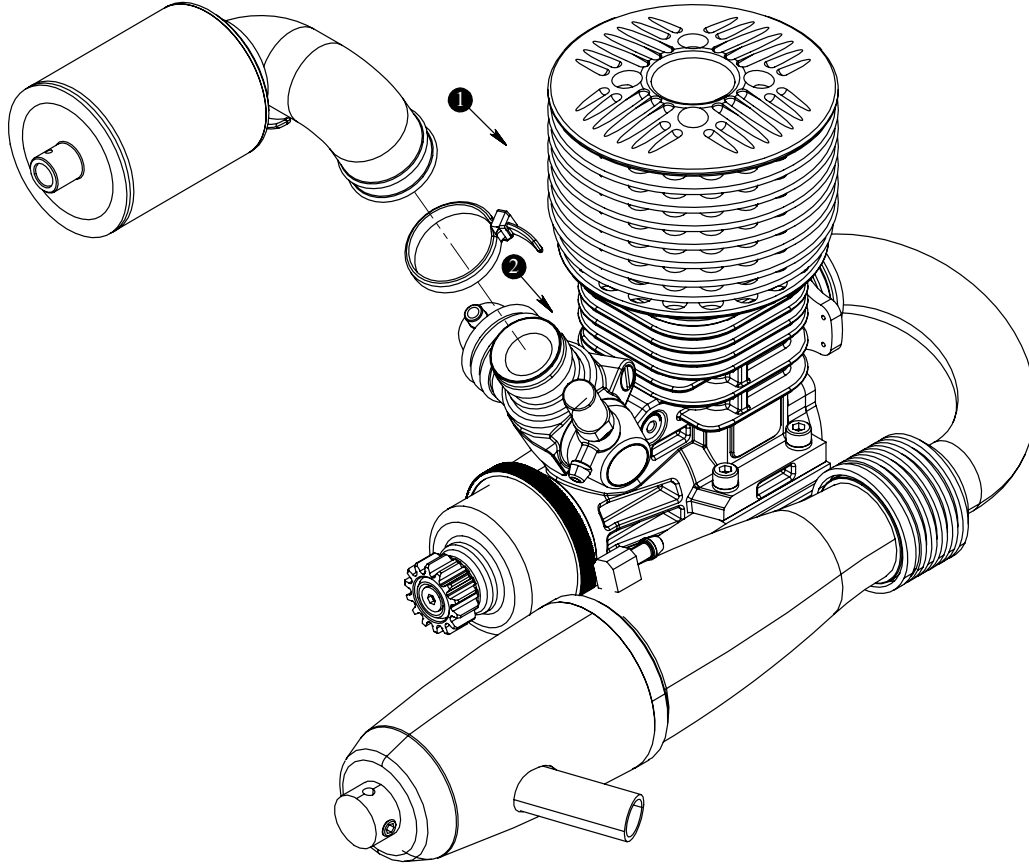

□ **STEP G-06**

Pipe Mount Assembly

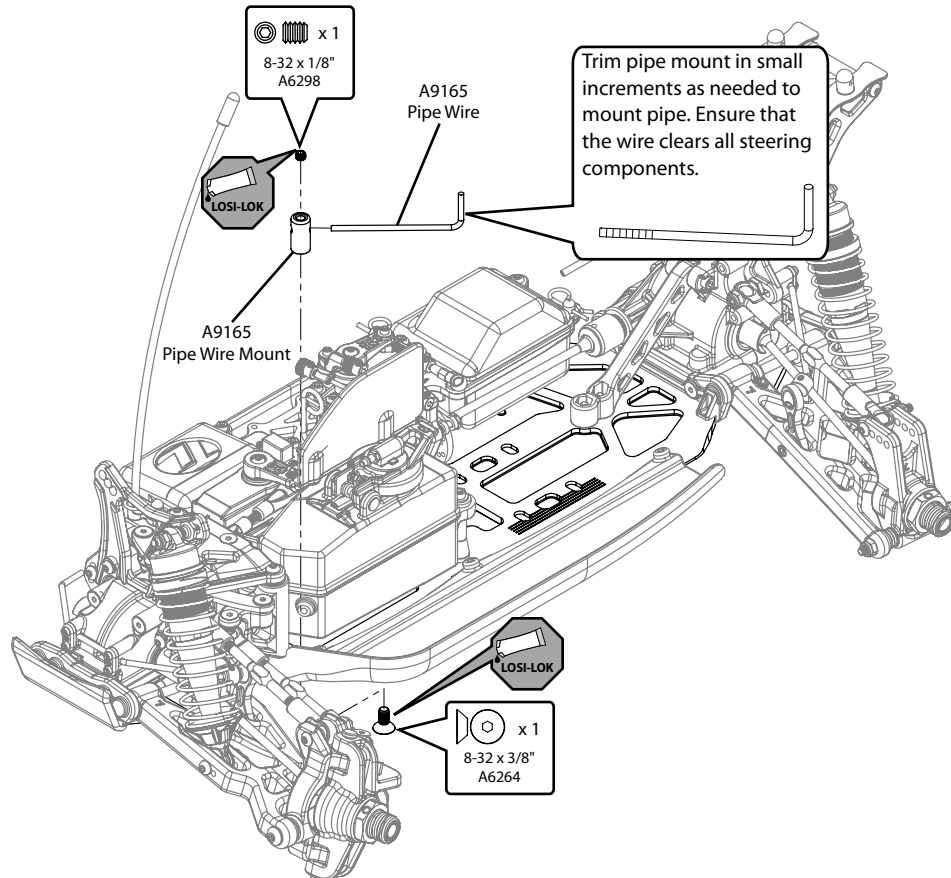

STEP G-07

Engine Installation

- Adjust the gear mesh between the Clutch Bell and the Spur gear by sliding the engine mounts in the slots of the chassis. In order to function properly, the Gears should be as close as possible, but still have a small amount of backlash (space between the Gear teeth).
- Place a piece of paper between the Clutch Bell gear and Spur gear, slide the engine sideways until the paper is pinched between the gears and tighten the engine mount screws. This will give a small amount of space between the gears.
- You should be able to rock one gear back and forth *slightly* while holding the other one steady. Be sure to check the gear mesh all the way around the spur gear.
- Once the engine alignment and gear mesh are correct, tighten all of the screws. Re-check the gear mesh after all the screws are tight to ensure the engine mounts did not move.

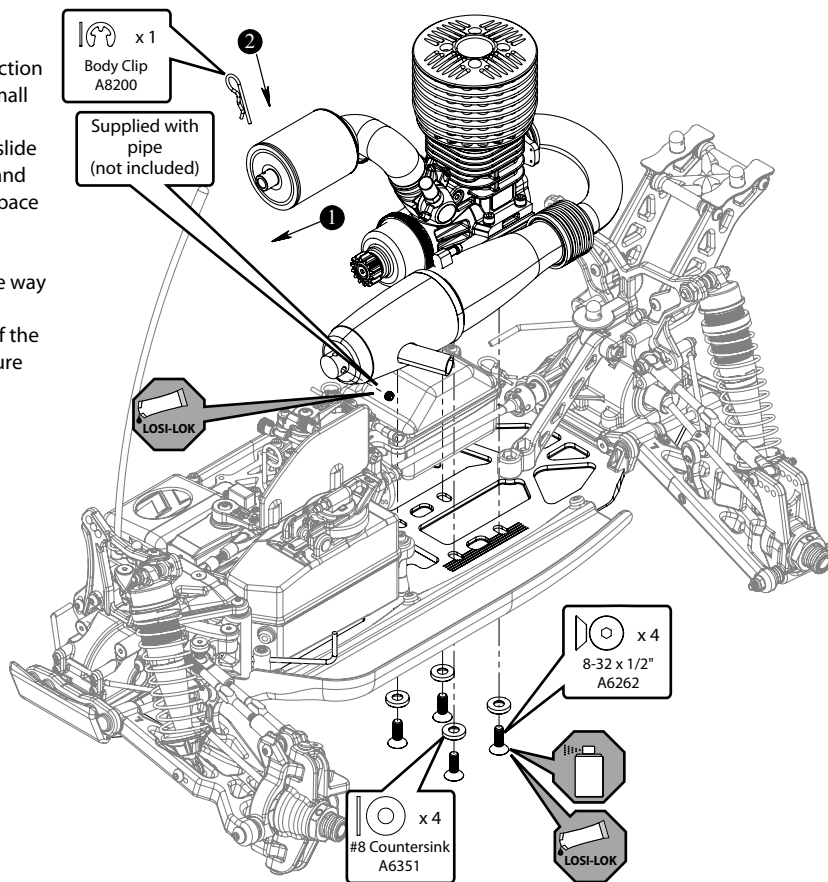
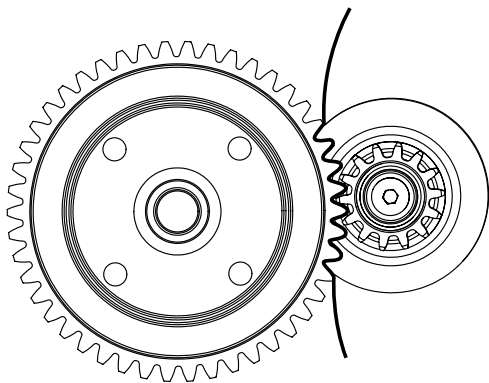

STEP G-08

Fuel Tube/Completed Engine Assembly

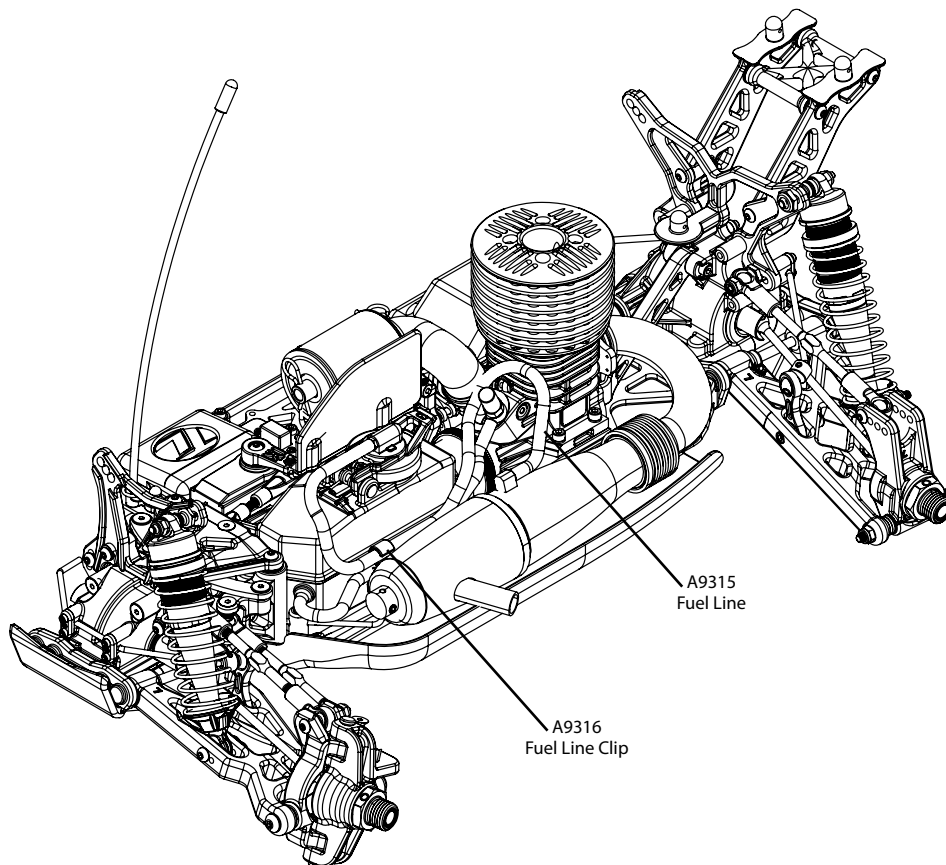

□ **STEP H-01**

Tire Mounting

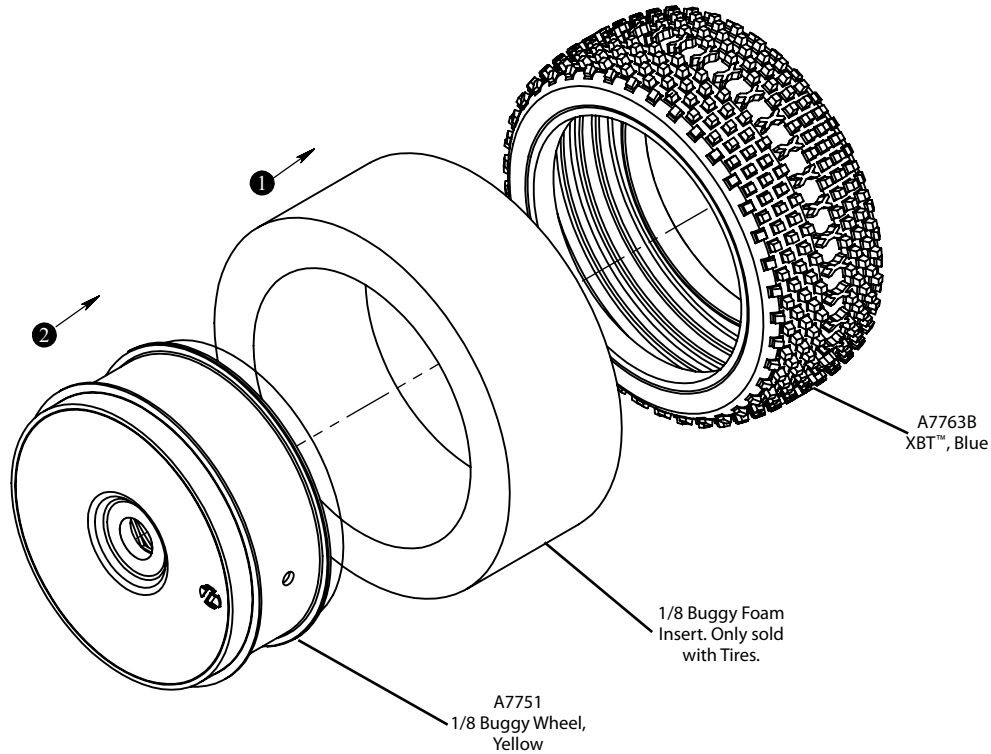

□ **STEP H-02**

Tire Gluing

- The tires are already glued to the wheels. Here are the steps to show you how to complete this process. This can be done by using a fast-curing super glue or cyanoacrylate glue (LOSA7880, LOSA7881), available at your local hobby shop. Install a tire gluing rubber band around the outside of the tire, in line with the bead to hold it onto the wheel.
- Now slightly pull back the tire bead from the wheel and apply a thin bead of glue between the tire bead and the wheel all the way around, wait for this side to dry and do the same to the other side until the tire is firmly adhered to the wheel. Allow the glue to dry thoroughly before continuing.

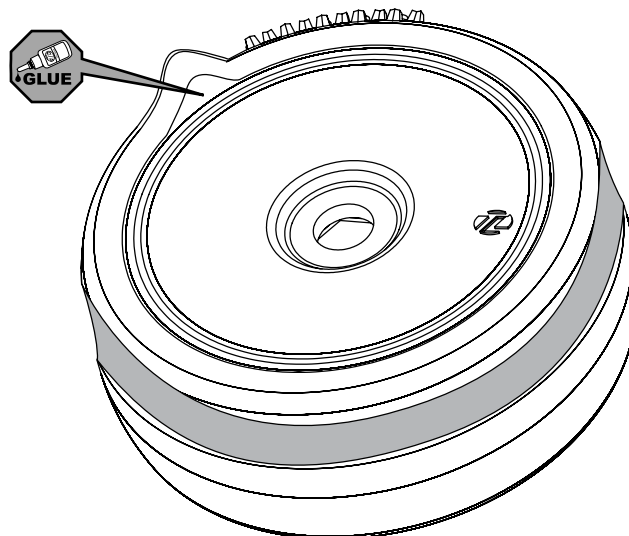

□ **STEP H-03**

Tire Installation

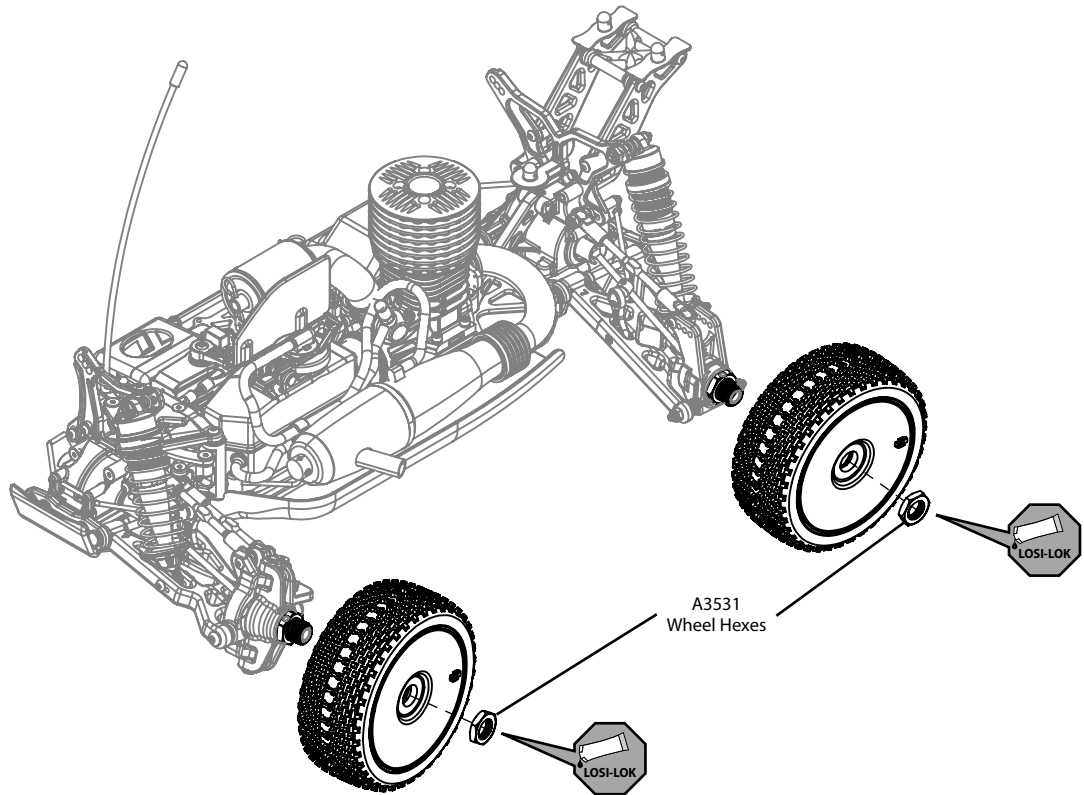

□ **STEP H-04**

Wing Installation

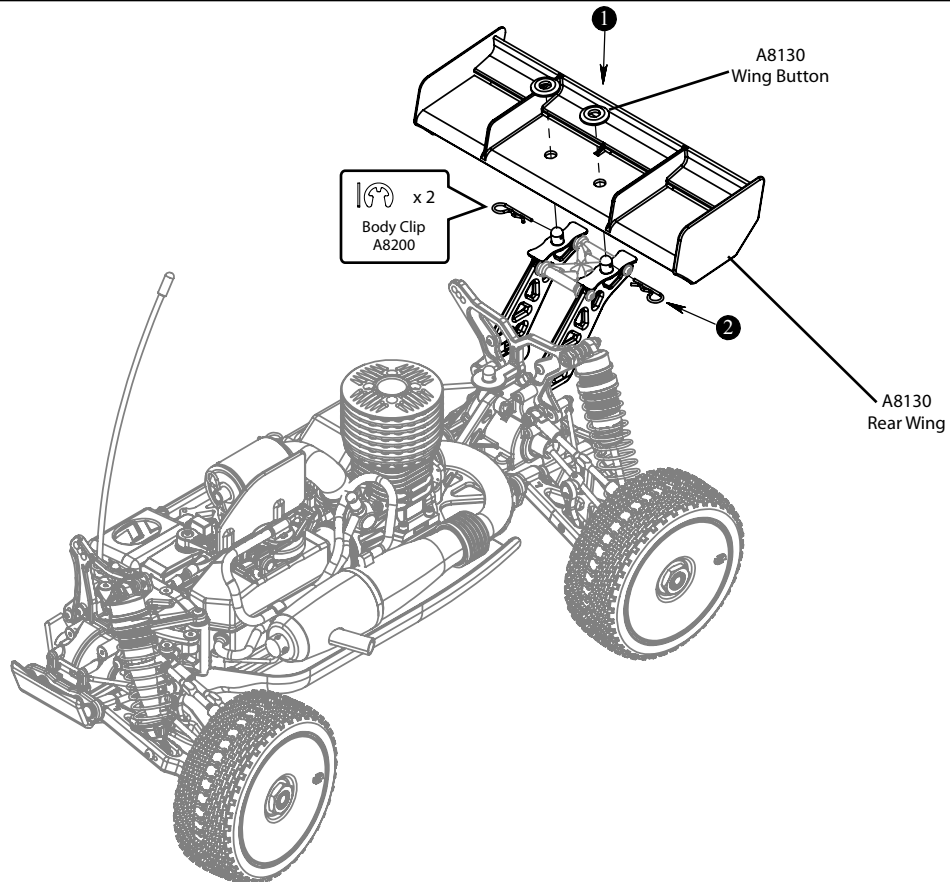

□ **STEP H-05**

Body Painting & Trimming

Painting:

Prepare the Lexan Body for painting by washing it thoroughly (inside and out) with warm water and liquid detergent. Dry the body with a clean, soft cloth. Use the supplied window masks to cover the windows from the inside. A high-quality masking tape should be used on the inside of the body to mask off any stripes, panels, or designs that you wish to paint on the body. Use acrylic lacquer or other paints recommended for Lexan (polycarbonate). (NOTE: LEXAN RC CAR BODIES ARE MEANT TO BE PAINTED FROM THE INSIDE!) Apply paint to the inside of the Body. Remove the masking tape for the next color and continue. Try to use darker colors first. If you use a dark color after a light color, apply a coat of white paint over the lighter color before applying the darker color, or if you are painting over white, coat it with silver. This will help prevent the darker color from bleeding through the lighter color.

Mounting:

The body is already cut out for mounting. However you will need to cut out the area for the pipe stinger. This should be done before you paint your body so you can easily see where it exactly needs trimmed.

Stickers:

After the body is mounted, REMOVE THE PROTECTIVE FILM ON THE OUTER SURFACE, now you can apply the stickers.

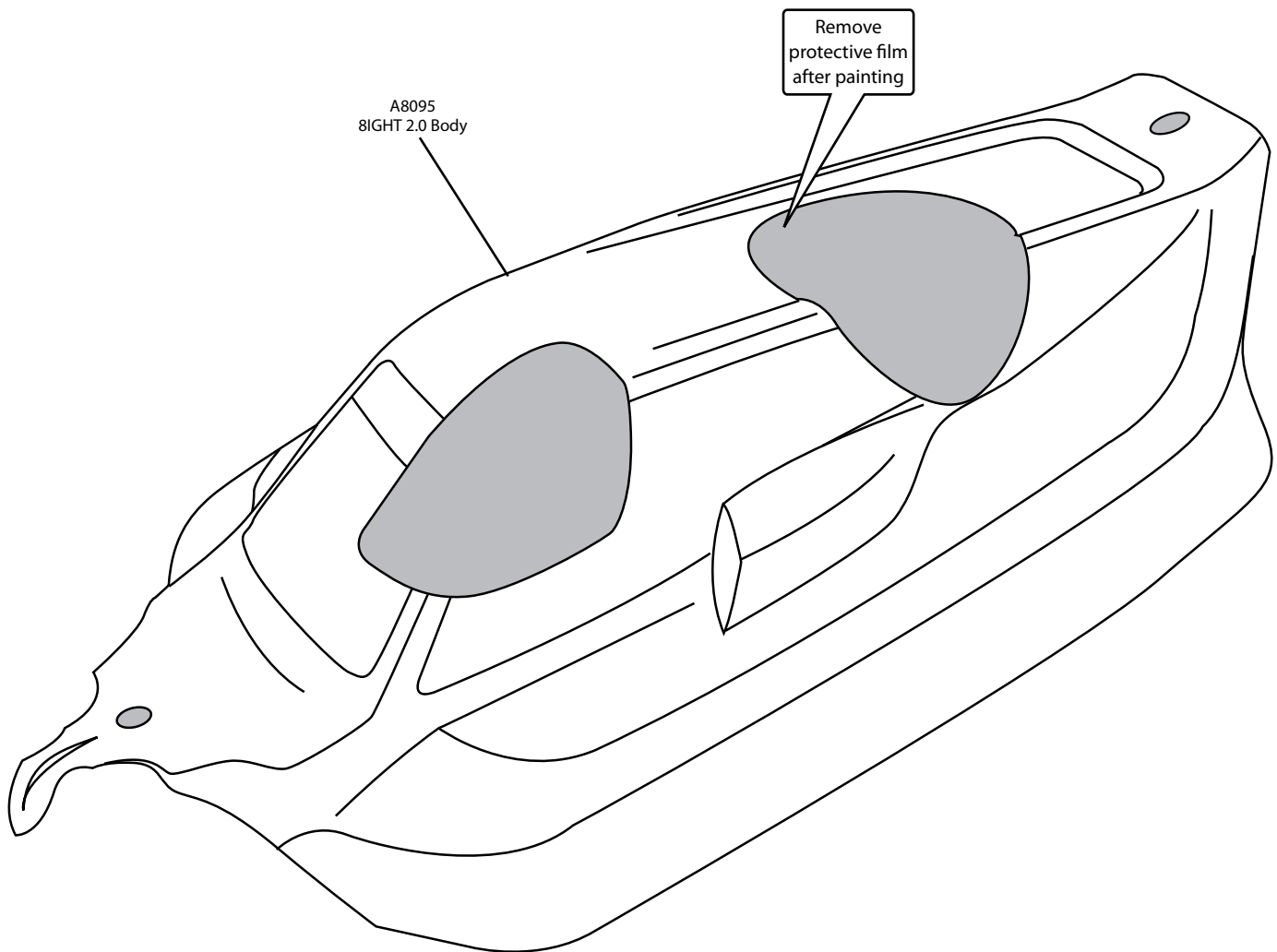

□ **STEP H-06**

Body Mounting

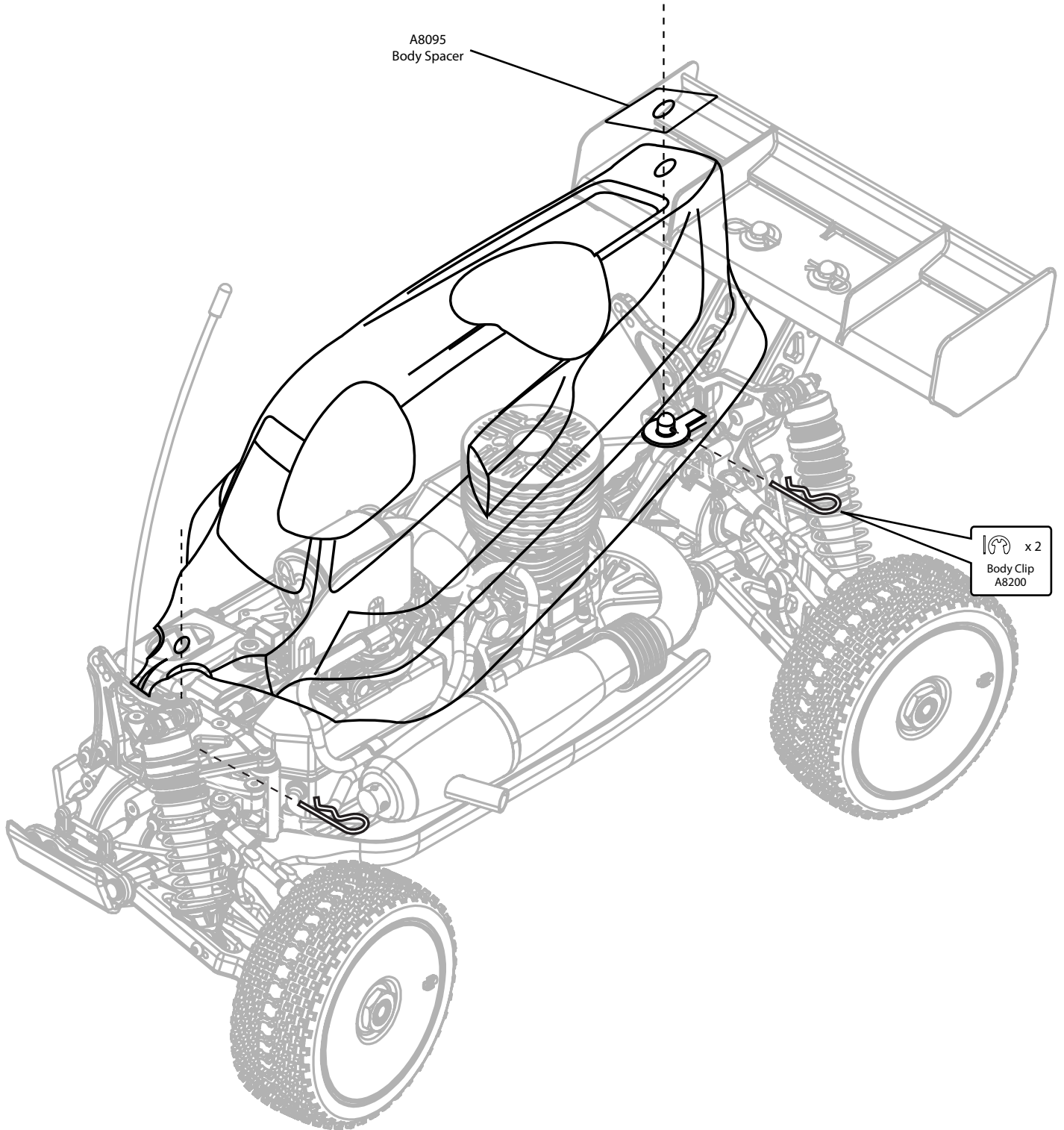

□ **STEP H-07**

Completed Chassis Assembly

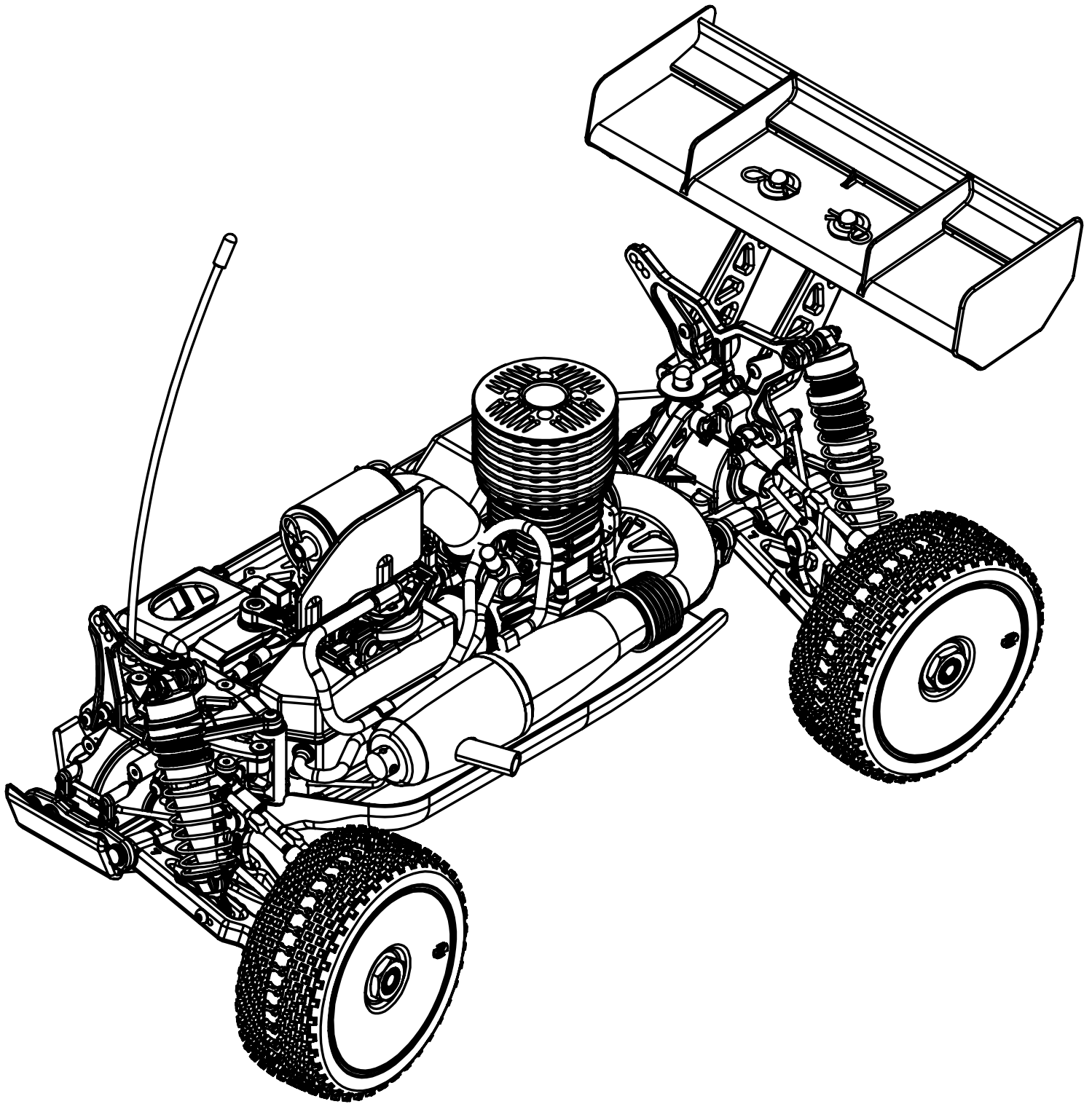

BEFORE RUNNING YOUR NEW 8IGHT 2.0 OFF-ROAD RACING BUGGY for the first time, you should run down the following checklist in order and complete the listed tasks. We're sure you're anxious to get out and run your new 8IGHT 2.0 now that it's built, but please note that fine-tuning of the initial setup is an essential part of building a high-performance racing buggy such as your new 8IGHT 2.0. Following this simple Checklist and the Team Tips will help to make the first run with your new car much more enjoyable.

1. Breaking in the differential:

While holding the chassis with **only** the left side tires firmly on the ground, give the car about one eighth throttle, for 30 seconds. The right side tires should spin freely during this time. Repeat this with **only** the right side tires held firmly to the ground, allowing the left tires to spin. Repeat these steps at least two more times.

2. Check for free suspension movement:

All suspension arms and steering components should move freely. Any binds will cause the car to handle poorly.

3. Set the ride height:

Set the ride height on your buggy so that the bottom of the chassis is 27mm from the ground in front and 29mm in the rear by adjusting the shock adjustment nuts, effectively increasing or decreasing pre-load on the springs. See the Setup Guide for additional information on ride height adjustment.

4. Set the camber:

Adjusting the camber tie rod length changes the amount of camber. Use the Losi wrench to adjust the tie rods once installed. Rotating the tie rods towards the front end of the vehicle will shorten the length, increasing negative camber. Rotating the tie rods towards the back of the car will lengthen them, increasing negative camber. Set the front tires to have 1 degree of negative camber and ensure that they are adjusted equally, left to right. Set the rear tires to have 2 degrees of negative camber and ensure that they are adjusted equally, left to right.

5. Set the front toe-in:

Adjust the front steering tie rods so that when the servo is centered on the transmitter, the front tires are both pointing slightly out with 2 degrees of toe-out. Refer to the Setup Guide for more information on toe-in/out.

6. Charge a receiver battery pack:

Charge a battery pack as per the battery manufacturer's and/or charger manufacturer's instructions so that radio adjustments can be made.

7. Set the transmitter steering trim:

The steering trim tab on the transmitter should be adjusted so that the car rolls straight when you are not touching the steering wheel/stick. If the servo and steering link were installed correctly, the wheels should turn equally to the left and right. If this is not the case, refer to Table 2 and ensure that the steering servo and horn were properly installed. Also check the steering link length as noted in Step A-01. Make sure the throttle trim is set so that the brakes are not "dragging" in the neutral position.

8. Set the transmitter throttle and brake trim:

The throttle trim tab on the transmitter should be adjusted so that the brakes are not dragging in the neutral position. The idle adjustment screw on the carburetor should be set at approximately 1mm open. When the throttle trigger is pulled back to the maximum, the carburetor is fully opened.

TIPS AND HINTS FROM THE TEAM

Before you start making changes on your 8IGHT 2.0 Off-Road Racing buggy, you need to make a few decisions. First of all, tires, and how they are set up, have a tremendous impact on overall performance. Before you start making changes on the chassis setup, take a moment to observe a few of the fastest cars at the track and what type of tire and inner liner they are running. You will find the best adjustment will become a personal decision based on the "feel" that each of these adjustments yield. Never make more than one change at a time; if the change you made works adversely, or doesn't address your need, return to the previous position and try something else. Team Losi Racing development team has put hundreds of hours on the 8IGHT 2.0 to arrive at the setup we put in the instruction manual. If you find that you have lost the "handle" go back to the vehicle (stock) setup, as this setup has proven to be reliable, consistent and easy to drive.

All of us at Losi are sure that you will find the 8IGHT 2.0 Off-Road Racing Buggy to be the most versatile and easiest car to drive fast, with great consistency. We hope the information in the following guide helps you to enjoy your 8IGHT 2.0, and racing it, as much as we do. For the latest in setup and accessory parts information, visit the Losi web site at: www.losi.com regularly. Please check the Losi web site periodically to find out new setup information as we are always testing on all types of tracks and surfaces. Also note that there are many ways to set up a car. The rules we follow can reverse sometimes with different driving styles or different setup styles, so test for yourself and you will find a set up that works right for you.

Tuning the Engine:

Should be done following the manufacturer's instructions. Turning the needle valve clockwise, the fuel mixture will become leaner – meaning that the engine will draw less fuel. When the needle valve is turned counterclockwise, the fuel mixture becomes richer, meaning that, the engine will draw more fuel. The high speed needle affects the fuel mixture at fuel throttle while the low speed needle only affects the fuel mixture at idle and the low end of the throttle band. Our recommended engine and pipe combo for your Team Losi Racing 8IGHT 2.0 is the GRP Mario Rossi tuned .21 engine and GRP 2053 Pipe.

To Shut Off the Engine:

Simply use the included pipe plug or simply bump the flywheel with a wrench or plastic handled tool. Losi also makes a tuning driver with a built-in plug for the pipe (LOSA99167).

The Receiver Battery:

The receiver battery is an important, frequently overlooked part of gas-powered vehicles. A low receiver battery can cause the vehicle to have a mind of its own. The result can be runaway vehicle or a poorly responding radio system. The length of time that a receiver battery pack's charge lasts depends on the type of servos that are used. If you will be using a NiCd or NiMH receiver pack, it is recommended that a minimum battery size of 1100mAh and minimum voltage of 5.4 volts be used. Recommended batteries that are offered by Losi are LOSB9950 6V 1100mAh NiMH Receiver Pack or LOSB9820 7.4V 2000mAh 2C LiPo Receiver Pack. Please note that a voltage regulator will be needed if you choose to use a Lithium Polymer (LiPo) receiver pack. Losi offers voltage regulators with a switch, LOSB9608 and without a switch, LOSB9609.

Droop:

Always measure the droop of the 8IGHT 2.0 with the shocks on the buggy. Droop is always measured from the center of the top shock mount to the center of the bottom shock screw. More droop (travel) in the front will have more on-power steering and allow the buggy to roll more on the rear when on throttle. More droop (travel) in the rear will increase off-power steering and allow the buggy to roll on the front when off throttle. More front and rear droop will accelerate better in bumps when going straight, but can cause the buggy to traction roll in rough turns. Less front and rear droop will slide over bumps better in turns and may be better on high-speed and high-traction tracks.

Front Camber Links:

The lower camber link locations on the tower have more camber gain (total camber change through the suspension travel). Running the camber tie rod in the lower holes will increase off-power steering and make the vehicle more aggressive; however you may lose some consistency. More camber gain is good on small tight tracks. We have found that running less camber gain in the front suits the car the best for consistency and steering balance. On the 8IGHT 2.0 we offer a longer camber link on the spindle carrier. A longer front camber link will make the vehicle feel stiffer and this will keep the buggy flatter with less roll and increase high-speed steering. A short front camber link will roll more and make the vehicle more aggressive. Too short of a front link may make the vehicle feel twitchy.

Rear Camber Links:

The 8IGHT 2.0 now has only three camber locations on the rear tower, however, we have added another inside hole on the rear hub. The stock camber link setup for the 8IGHT 2.0 is location #2 on the tower and B in the hub. By using a longer rear camber link you will have less roll and improve stability and traction. A shorter rear camber link will have more roll and increase steering and better handling in the bumps. Running "A" in the rear hub will generate more corner rotation entering the turn, but decrease steering on exit. Running "B" in the hub will be more stable entering the turn and increase steering on exit.

Pistons:

Generally smaller hole pistons, #56, have stiffer damping, slower weight transfer, slower response, and will land large jumps better. Larger hole pistons, #54, have softer damping, increased traction, quicker weight transfer/response, and bottom out easier off large jumps.

Shock Oil:

Lighter shock oil has more overall traction and responds quicker. Thicker oil has less overall traction and reacts slower. On high bite/smooth tracks, thicker oil is easier to drive. Make sure you adjust oil when there is a drastic temperature change (20-25 degrees). If it gets cold outside you need to go to lighter shock oil. If it gets hotter outside you need to go to thicker weight shock oil.

Front Toe:

You never want to run toe-in on the front of the 8IGHT 2.0. Front toe-in (longer steering rods) decreases steering response entering and in the middle of the turn but will increase on power steering. Toe-out (shorter steering rods) increases steering response when entering the turn and increases straight line stability, however, it will decrease on power steering.

Rear Toe-in:

The 8IGHT 2.0 is equipped with 3 degrees of toe-in per side. Less rear toe-in will increase the wheel base of the buggy and decrease forward traction, but will increase top speed and side traction in the middle of a turn. More toe-in will increase forward traction, have more off-power steering and less side traction.

Wheel Base:

The 8IGHT 2.0 is equipped with a long wheelbase. A shorter wheelbase (spacers behind the rear hubs) increases on-power traction, rear weight transfer, and has more off-power steering. A shorter wheelbase is better on tight or slick tracks. A longer wheelbase (spacers in front of the rear hubs) decreases off-power steering, is more stable, better in bumps, and has more on-power steering.

Sway Bars:

The 8IGHT 2.0 is equipped with 2.3mm sway bars on the front and rear. A thinner front sway bar increases front off-power traction, but has less on-power steering. A thicker front sway bar decreases front off-power traction making the steering smoother entering the turn, but has more on-power steering. A thinner rear sway bar increases rear traction and decreases on-power steering. A thicker rear sway bar increases stability in the middle of the turn and increases on-power steering. Thicker sway bars are more stable on high-speed, high-traction tracks.

Clutch:

On new clutch bells make sure to clean the inside of the clutch bell with scouring pad or fine sand paper to improve the break-in period. Softer springs engage at a lower rpm and have a smoother power band. If the engine doesn't have enough low-end power try running more preload (spring with more angle) or a stiffer spring. Stiffer springs engage at a higher rpm and hit much harder. If the springs are too stiff it will cause the clutch to slip.

Plastic vs. Aluminum Clutch Shoes:

We have found the two plastic and two aluminum clutch setup to work best on most tracks, but if the track is very loose, rough, and doesn't have jumps that are difficult to get over, four plastic shoes will allow more slip and smoother acceleration. Running all four aluminum clutch shoes will have the most punch, but isn't as good on slick, rough tracks. Our recommended clutch setup is two aluminum shoes with gold springs and two plastic shoes with green springs. Whenever you need to rebuild your clutch we recommend the following tips. First of all, be sure to clean all parts with Losi Nitrotec™ Spray Cleaner (LOSA99217) to ensure there is no oil or debris on any of the parts. Cleaning will include all clutch parts including the clutch bearings. We like to spray out the clutch bearings to ensure that there is no grease slung from the bearing at high rpm which would cause premature clutch wear or slippage. When reinstalling the clutch pins we recommend NOT using any type of Losi-Lok on the clutch pins. By using Losi-Lok on this part, it only makes it difficult to remove the pins. Once the new shoes are installed, pull back each clutch shoe 1mm to make sure they spring back to position to ensure proper movement. You will also want to make sure the clutch bell has anywhere from .25mm to .50mm of movement and spins freely on the crank shaft. You can use Losi's Metric Shim Set, LOSA6356 to dial this in properly. Now that your clutch is fully rebuilt it is time to break it in. This is done by starting your buggy and having it idle on the ground. While firmly holding the vehicle down, apply 1/2 throttle for three seconds. Repeat this three times to fully seat in your new clutch.

Here is a layout of clutch setups ranging from softest to hardest in acceleration

	Clutch Setup Number	Shoe/Spring	Description
Clutch Engagement Softest to Hardest	1	4 Plastic with Black	Ultimately the smoothest and easiest to drive setup
	2	2 Aluminum with Black 2 Plastic with Black	Used on very loose tracks where little punch is needed
	3	4 Plastic with Green	Used on loose high-speed tracks where there are no jumps out of turns
	4	2 Aluminum with Green 2 Plastic with Black	Very smooth, yet has good punch. Motor must have adequate power to pull this clutch setup
	5	4 Plastic with Gold	Very forgiving and reduces wheel spin with punch being sacrificed slightly. Can be used with motors that have great bottom end
	6	2 Aluminum with Gold 2 Plastic with Green	Good all around setup. Best compromise for punch and mileage
	7	2 Aluminum with Gold 2 Aluminum with Gold	Increased punch with slightly less mileage
	8	4 Aluminum with Gold	Increased punch, good for jumps right out of turn, with average mileage.
	9	4 Aluminum with 2 Silver and 2 Gold	Very aggressive with great punch, engine will run hotter and shoe life will diminish
	10	4 Aluminum with Silver	Most aggressive, maximum punch. Use with motor that has very low bottom end

Differentials:

The 8IGHT 2.0 comes equipped with 5000 wt in the front and center diff, and 2000 wt in the rear diff. Thinner front differential oil increases off-power steering, but if the oil is too thin the steering will become grabby and inconsistent. Thicker front differential oil increases off-power stability and increases on-power steering. Thinner center differential has less forward drive, can unload more under acceleration and is easier to drive on rough and slick tracks. Thicker center differential has more acceleration, increases on-power steering, and less off-power steering. Thicker center differential is better on high bite/smooth tracks. Thinner rear differential has more cornering traction and increases steering in the middle of the turn. Thicker rear differential has less steering in the middle of the turn and more forward traction.

Shock Mounting Positions:

More inclined (moving the shocks in on the tower) has softer initial damping and is more forgiving. Less inclined (moving the shocks out on the tower) makes the car more responsive and is better for technical tracks.

Ackerman:

A long Ackerman plate will have smooth off-power steering and is more forgiving. The long Ackerman plate will have more steering on-power. A short Ackerman plate responds quicker and has more steering in the middle of the turn. A short Ackerman plate is better suited for tight technical tracks.

Camber:

More negative camber in the front has more steering and is more responsive.

Less negative camber in the front will have less steering and will be smoother.

More negative camber in the rear will have less rear traction, but will increase on-power steering and will be less grabby in bumps. Less negative camber in the rear will have more rear traction and make the rear of the buggy stay flatter, but if traction is lost it will be more violent. To ensure your 8IGHT 2.0 has the correct camber we recommend using our Losi Camber Gauge (LOSA99172).

Fuel Tank:

Your 8IGHT 2.0 comes preinstalled with a fuel tank insert to meet ROAR and RC Pro Series 125cc fuel tank rules. If you are not racing your 8IGHT 2.0 where these rules apply, you can remove the insert to allow for an additional 5cc of fuel and longer run time. Also included in your 8IGHT 2.0 is an EFRA Fuel Kit. This should be used at all EFRA races to ensure your fuel tank volume will not change during racing. The EFRA Fuel Kit ensures that the fuel line and clunk does not come out of the tank, increasing fuel volume. Below is a diagram on how to install the EFRA Fuel Kit.

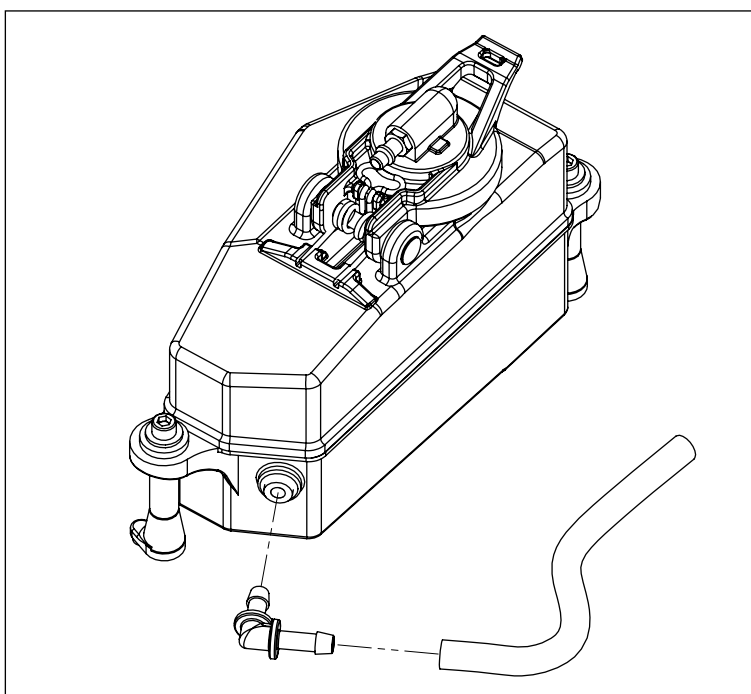

Gearing:

The stock gearing for the 8IGHT 2.0 is 13/48. If you are running on a large sweeping track and need more top speed, a 14-tooth clutch bell (LOSA9117) is recommended.

Brake Setup:

The standard brake bias for the 8IGHT 2.0 is 60% rear - 40% front. If you need the buggy to rotate more under braking, adjust the linkage for less front brake. If the buggy is loose entering turns under braking, adjust the linkage for less rear brake or more front brake.

Outdrives and Traction:

When your 8IGHT 2.0 is new it will have a lot of chassis roll and be a little loose on throttle due to lack of friction in the out drives and crossbones. After about 45-60 minutes of running, the 8IGHT 2.0 will gain traction and stability. Once your 8IGHT 2.0 is broken in, replacing the out drives and crossbones with new parts will have more corner speed.

Bump steer:

Running the bump steer ball down you will have smoother steering in the middle of the turn. With the bump steer ball up, this will increase steering in the middle of the turn.

Rear Squat:

The 8IGHT 2.0 comes with three degrees of anti-squat. Running less anti-squat will have less off-power steering and roll (side to side) more on the rear. Less anti-squat will accelerate better in small bumps. More anti-squat will have more support (side to side) and be better on rough tracks with big jumps.

Ride Height:

Measuring from a flat surface to the bottom face of the chassis, adjust the front of the chassis with 27mm of ride height and 29mm in the rear. We have found the 8IGHT 2.0 handles best when the front ride height is 1mm to 2mm lower or at least level than the rear of the truck. To measure your ride height properly we recommend using the Losi Ride Height Gauge (LOSA99173).